



Therma-Tru[®] Hinged Patio Door System



1750 Indianwood Circle Maumee, OH 43537
1-800-THERMATRU (843-7628)
www.thermatru.com

Unit Installation

Read all instructions before starting.

The applicable standards for these products are governed by
the International Residential Code.
Copies of performance ratings and testing are available on our website
www.thermatru.com and our product manual.

Part identification

Not all parts shown will be included in package.
Parts will vary for type of unit purchased.

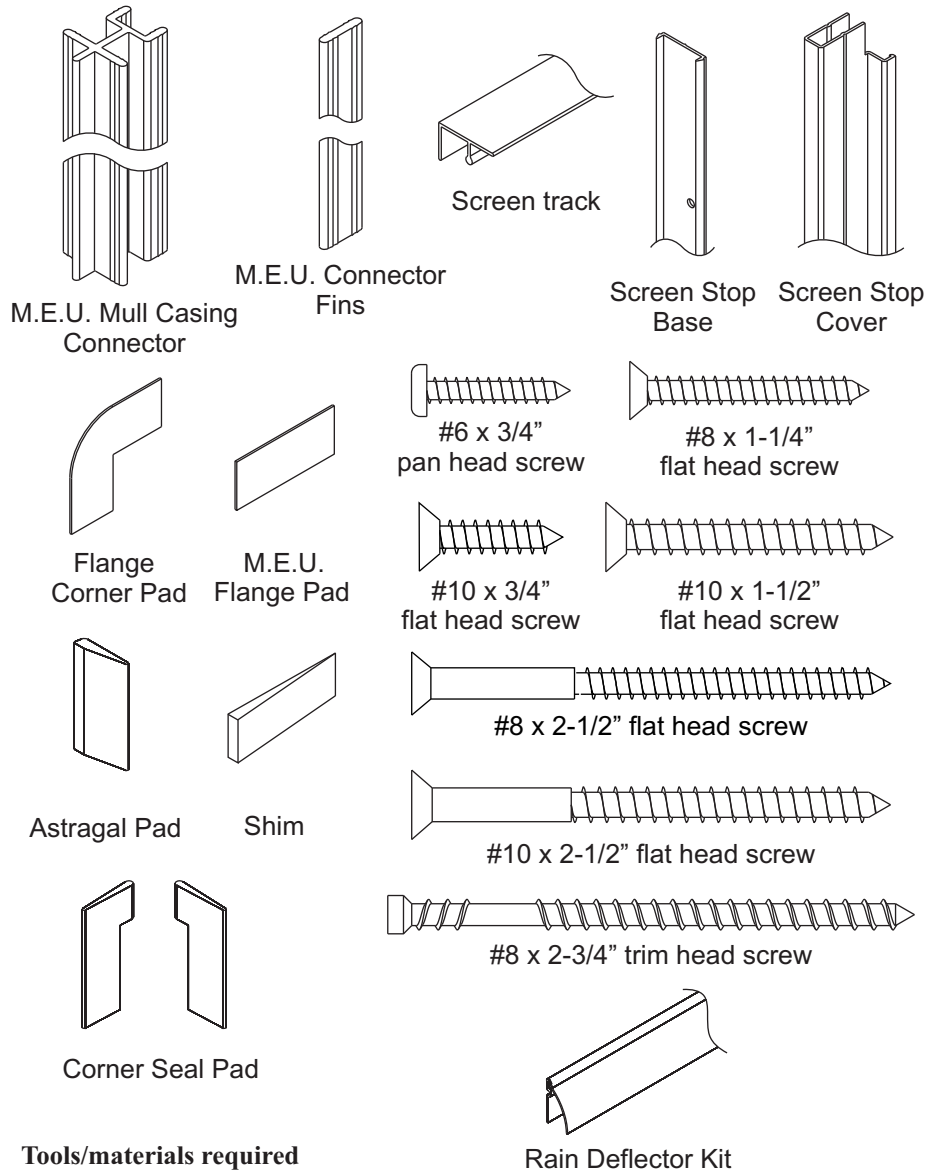

Tools/materials required

This is a listing of tools that may be required to assemble unit.

- Drill/screw gun
- Sealant (Elastomeric or Polyurethane)
- Caulk gun
- Rubber mallet
- 3/32" & 1/8" drill bit
- Tape measure
- Phillips head drive bit or screwdriver
- Structural adhesive
- Utility knife
- Hammer
- Level
- Metal Shears

FINISHING INSTRUCTIONS

Work only when temperatures are between 50° and 90°F and with humidity less than 85%. Do not finish in direct sunlight.

SMOOTH-STAR® UNITS

Painting Door Interior:

1. Clean first with mild detergent and water or use a TSP (tri-sodium phosphate) solution. Rinse well and allow to dry completely.
2. Mask glass and hardware.
3. Use high-quality acrylic latex house paint, following manufacturer's application instructions.
4. Paint edges and exposed ends of door.

Painting Frame Interior:

1. Clean first with a clean damp cloth. Allow to dry completely.
2. Mask hardware and weatherstripping. Weatherstripping may be removed from jambs by gently pulling out. Re-insert weatherstripping by pushing in after door is completely finished and dry.
3. Scuff frame using a Scotch-Brite pad or 180-grit sandpaper.
4. Paint using a high-quality acrylic latex house paint, following manufacturer's application instructions.

FIBER-CLASSIC® UNITS

Painting Door Interior:

1. Clean first with mild detergent and water or use a TSP (tri-sodium phosphate) solution. Rinse well and allow to dry completely.
2. Mask glass and hardware.
3. Prime with an alkyd- or acrylic-based primer. Allow primer to dry completely.
4. Paint with an oil-based or acrylic latex house paint, following manufacturer's application instructions. Use a primer and paint that are compatible.
5. Paint edges and exposed ends of door.

Painting Frame Interior: (see above for Smooth-Star units)

Staining Door Interior:

We only recommend the use of the stain and clear coat products found in the Therma-Tru Finishing System. (See the Therma-Tru Finishing System instructions for complete details.)

1. Clean first with a clean cloth and mineral spirits and allow to air dry OR wash door with a mild detergent and water, or a TSP (tri-sodium phosphate) solution. Rinse well and allow to dry completely.
2. Mask glass and hardware.
3. Apply stain with a cloth in a circular motion to one section at a time.
4. Wait 5-10 minutes before brushing, depending on the desire for a lighter or darker shade.
5. Brush with the natural bristle brush in the direction of the grain to "feather" or blend the stain to a rich wood look. *Clean brush tips frequently with a dry cloth to remove excess stain.* Stain and brush out each section completely before moving onto next section.
6. Allow a minimum of 48 hours drying time for the stain to cure before applying topcoat.

Staining Frame Interior:

1. Clean first with a clean damp cloth. Allow to dry completely.
2. Mask hardware and weatherstripping. Weatherstripping may be removed from jambs by gently pulling out. Re-insert weatherstripping by pushing in after door is completely finished and dry.
3. Prime, using Kilz2 latex primer color matched to a skin sample from the *Therma-Tru Finishing System*, following manufacturer's application instructions.
4. Apply stain from the *Therma-Tru Finishing System*.

24 INSTALL RAIN DEFLECTOR

Align the rain deflector base with the bottom edge of the door slab, 5/8" from either end of the door. Mark the four screw locations and set base aside.

Pre-drill 3/32" dia. pilot holes through the door slab for the mounting screws. Apply a 1/8" bead of sealant (Elastomeric or Polyurethane) along the channel on the back side of the base.

Using #8 x 1" screws, fasten the rain deflector base to the door panel.

With door in the open position, slide the rain deflector fin into the channel on the front side of the base from the either side of the door.

Apply a small amount of silicone to the fin on either end to prevent movement and rattle.

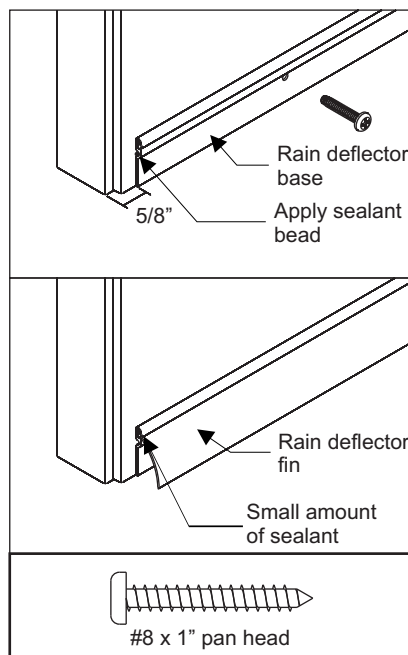

25 WEATHERPROOF, FINISH AND MAINTAIN

- Add insulation to air space between opening and unit.
- Seal around entire perimeter of unit on "weather" side; seal brickmould to siding or facing, seal front bottom edge of sill, seal all joints between jamb and mouldings.
- Use included patch stick to fill over trim head screws and finish nails.
- For larger holes, use *Minwax Wood Filler* or *Elmer's Fill-n-Finish*.
- Seal joints between exterior hardware trim and door face to prevent air and water infiltration.
- Provide and maintain a properly installed cap flashing to protect top surfaces from water damage.
- Paint or stain according to Therma-Tru instructions. Do not paint gaskets or weatherstrip. Weatherstrip may be removed for easier painting or staining.
- Swing-out doors must have all edges - sides, top, and bottom - finished. Inspect and maintain these edges as regularly as all other surfaces.
- Maintain or replace sealants and finishes as soon as any deterioration is evident. For semi-gloss or glossy paints or clear coats, do this when surface becomes dull or rough. More severe exposures require more frequent maintenance.
- All Therma-Tru doors must be finished and maintained in accordance with our recommendations. Failure to do so may affect the applicable warranty.

Warning : Modification or machining of this product can release wood dust, a substance known to the State of California to cause cancer.

1 REMOVE PACKAGING



Remove packaging but keep door fastened closed with transport clip. Do not remove clip or open door until instructed to do so. Proceed to step 5, *APPLY SEALING PADS*, if not attaching Multiple Extension Units.

2 REMOVE SIDE FLANGE, if applicable (Multiple Extension Units)

For units receiving Multiple Extension Units, remove flange on side to receive Multiple Extension Unit by carefully prying up an end and pulling straight up.

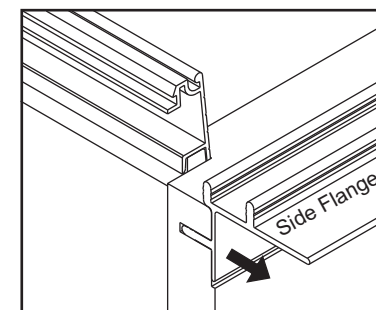

3 ATTACH MULTIPLE EXTENSION UNIT

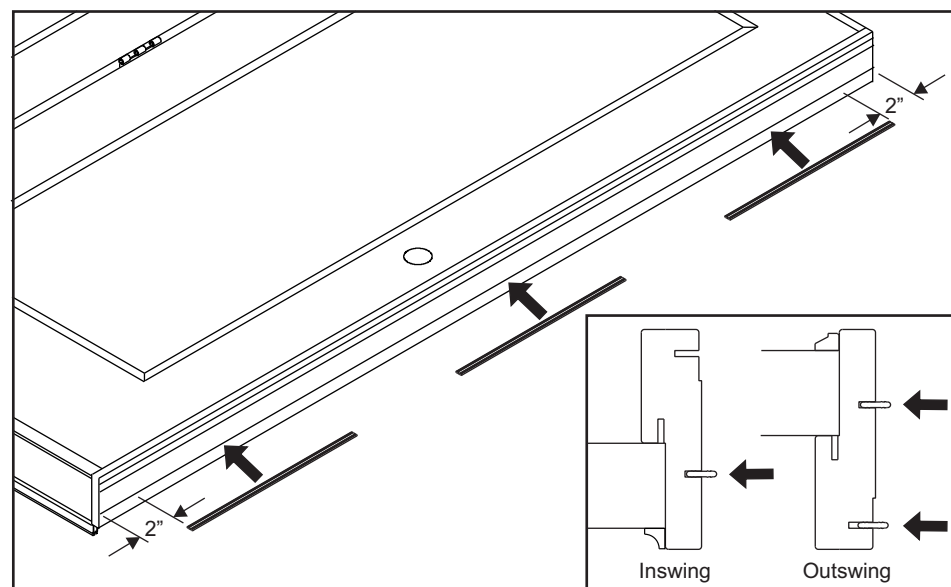

Install Connector Fins to Active Panel Unit

Carefully lay unit flat.

Align top and bottom connector fins approximately 2" from jamb ends.

Firmly press into specified groove shown using a rubber mallet if necessary.

3 ATTACH MULTIPLE EXTENSION UNIT - cont.

Install Mull Casing Connector (Inswing Units)

Set unit upright on sill.

Align connector with bottom edge of jamb.

Firmly press into groove using a rubber mallet if necessary.

Connector will be offset from top edge of jamb approximately 3/4".

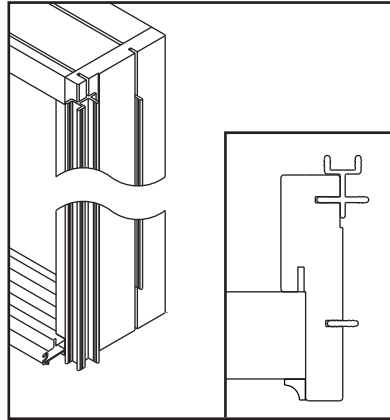

Apply Structural Adhesive

Apply (2) generous beads of structural adhesive along entire length of jamb mating surfaces.

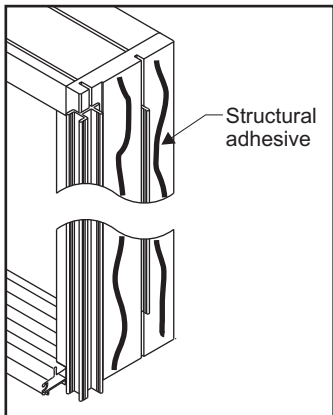

Attach Units

Align units and press firmly together until butted flush.

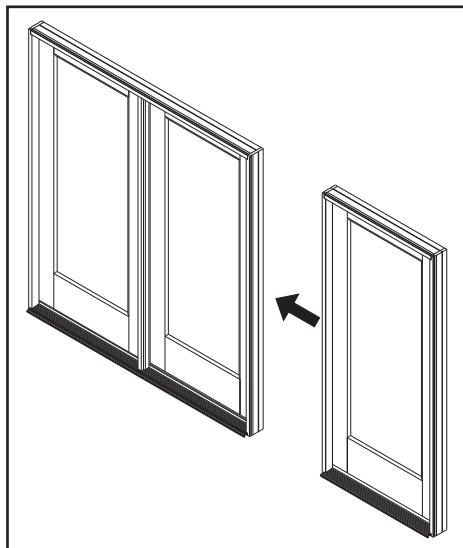

23 ATTACH SCREEN STOP (Triple Units)

See diagram below for correct placement of screen stop.

Place screen stop base on mullion, mark hole locations and pre-drill 1/16" dia. pilot holes.

Fasten screen stop base to mullion with #6 x 3/4" pan head screws.

Snap screen stop cover over base.

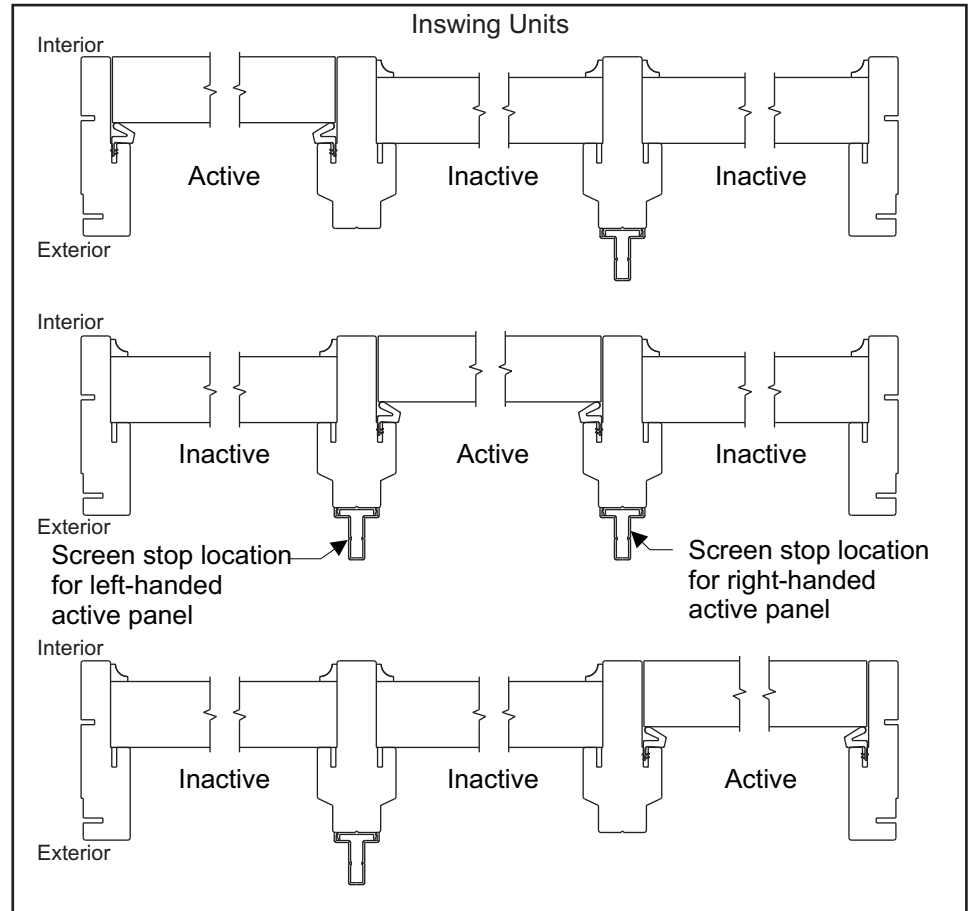
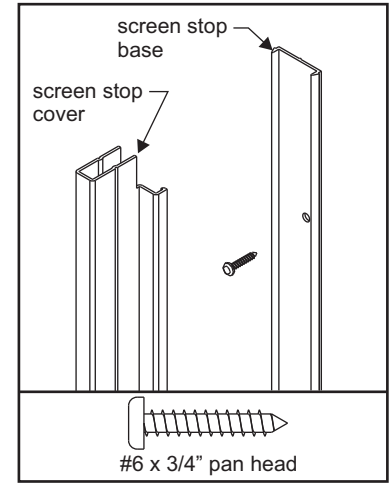

21 ATTACH MULL CASING (Multiple Extension Units)

Inswing:
Align mull casing and press firmly onto mull casing connector bars. Use a rubber mallet if necessary.

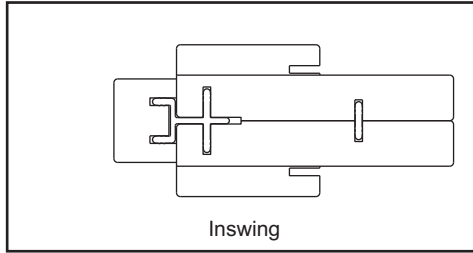

Outswing:
Align mull casing. Using 2" finishing nails (not supplied), fasten mull casing to jambs. Space nails approximately 8" apart.

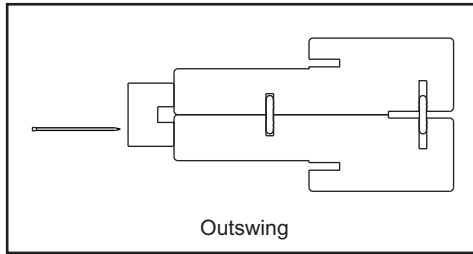

22 ATTACH SCREEN TRACK

Place screen track up on brickmould or jamb, depending on frame size.

Mark hole locations and pre-drill 1/16" dia. pilot hole into brickmould.

Fasten screen track with #6 x 3/4" pan head screws.

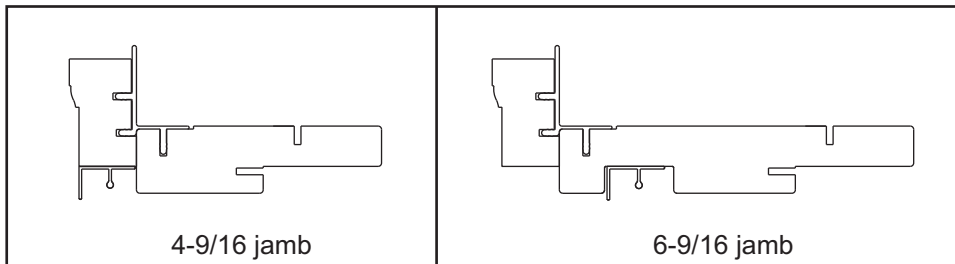
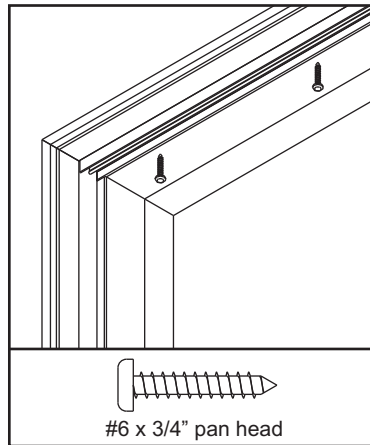

4 ATTACH FLANGES (Multiple Extension Units)

Align and Install Side Flanges

Align edge of side flange with bottom of side jambs.

Firmly press into kerf in jamb using a rubber mallet if necessary.

Flange will be set back approximately 1/2" from top edge of jamb.

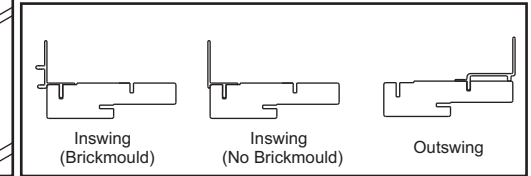
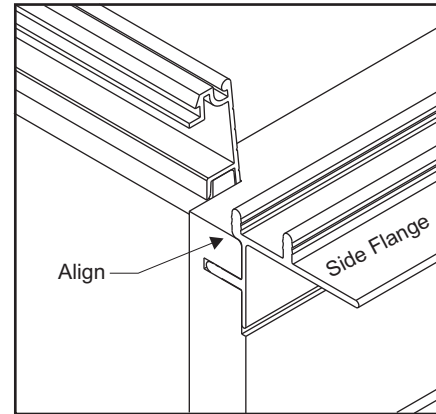

Install Top Flange

Center top flange into head jamb kerf and press into place using a rubber mallet if necessary.

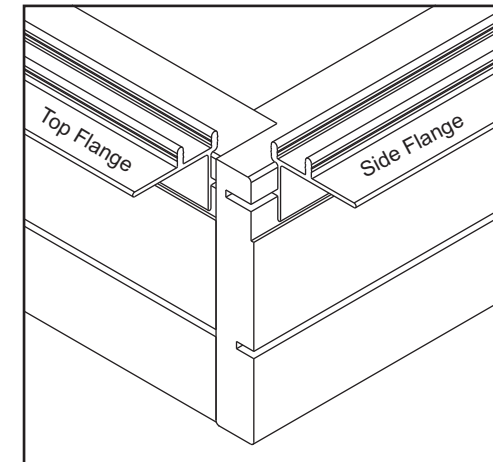

5 APPLY SEALING PADS

Peel off backing from flange sealing pads.

Align and apply to backside of flange (surface to be against opening).

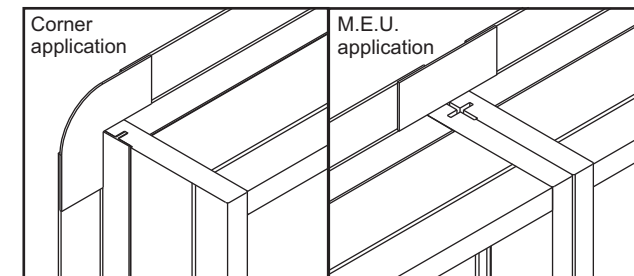

6 CHECK UNIT SIZE

Check height and width by measuring the frame, not flange.

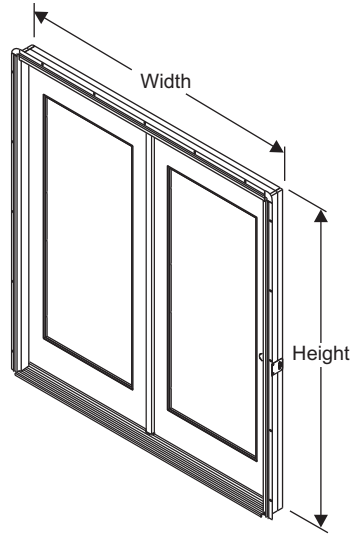

7 CHECK AND PREPARE OPENING

Is subfloor level and solid? *Provide a flat, level, clean bearing surface so the sill may be caulked and sealed to the opening. Scrape, sand, or fill as required.*

Shim subfloor for floor covering clearance, if required.
If shimming, caulk under shims.

Is opening square? Check all corners with a framing square. Double-check by comparing diagonal measurements.
Fix any problems now.

Are framing and walls plumb? Use a 6-foot level and check both sides of opening, both ways. *Fix any problems now.*

Are wall surfaces around opening in the same plane? There must be no “warps” or “jogs”. *Fix any problems now.*

Is opening correct size? Check it against door frame size now before installation. Opening should be frame height plus 1/2”, and frame width plus 1/2” to 1”.

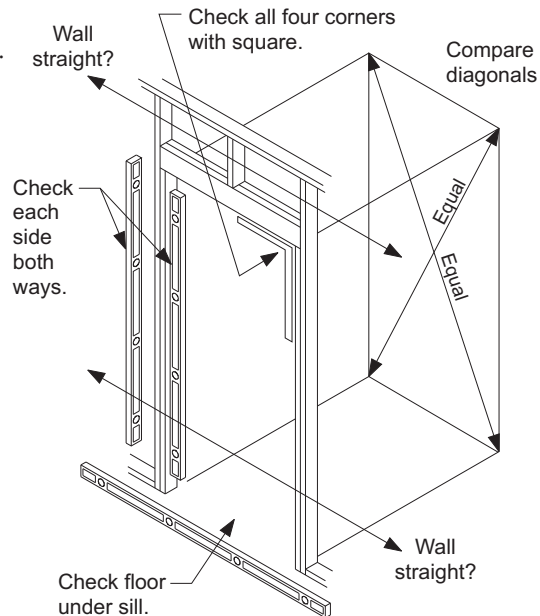

20 ATTACH BRICKMOULD

Inswing

Position kerfs in brickmould on flange bars. Do not press on completely until all brickmould pieces are properly aligned.

Firmly press on brickmould using a rubber mallet if necessary.

Pre-drill 3/32” dia. pilot holes through top of brickmould at corners.

Fasten with #8 x 1-1/4” flat head screws.

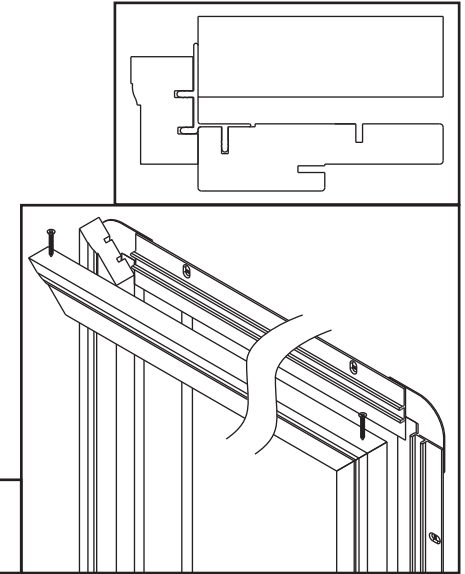
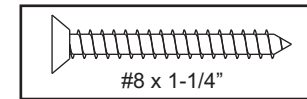

Outswing

Locate brickmould 1/4” from jamb edge as shown.

Fasten with 2” finishing nails (not supplied) locating nails approximately 8” apart and securing corners as shown.

Pre-drill 3/32” dia. pilot holes through top of brickmould at corners.

Fasten with #8 x 1-1/4” flat head screws.

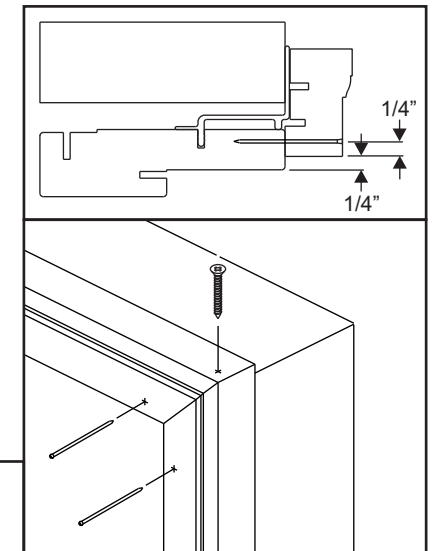
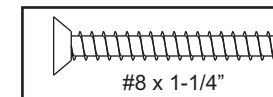

17 ANCHOR SILL

For outswing units, fasten sill to subfloor through pre-punched holes using #10 x 1-1/2" flat head screws.

For inswing units, drill 3/16" holes through the sill 6" from either end, and 12" on center.

Use #10 x 1-1/2" flat head masonry screws (not supplied) for concrete floor installation.

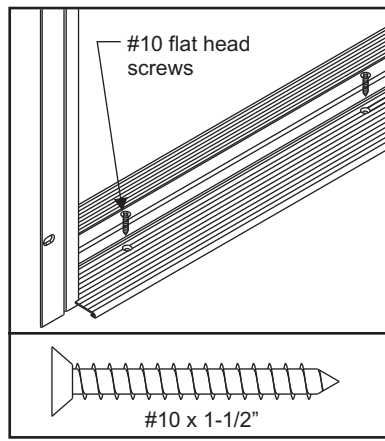

18 ADJUST THRESHOLD

For inswing units, remove screw cap on threshold and turn set screw accordingly to obtain a good seal with door bottom.

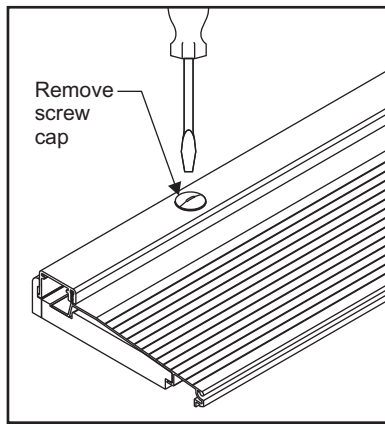

19 APPLY CORNER SEAL PADS



If unit will be painted or stained, apply corner seal pad after finishing.

For adjustable sills, after threshold adjustment, apply a bead of sealant (Elastomeric or Polyurethane) where threshold and jamb meet.

Peel off backing from corner seal pad.

Apply to jamb with thick portion of pad tucked behind weatherstrip.

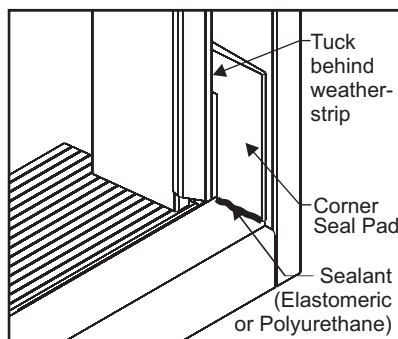

8 CAULK SUBFLOOR AND SILL BOTTOM

When no Sill Pan is used

Lay door unit on edge or face so that bottom side of sill can be caulked. Place very large beads of sealant (Elastomeric or Polyurethane) across full width at front edge of sill. Place one or more very large sealant beads at parallel lines across bottom surfaces which will bear on subfloor.

For Sill Pan option

Using a pair of metal shears, remove the corner of sill pan as shown to allow for clearance with the nailing flange. Then follow instructions included with sill pan.

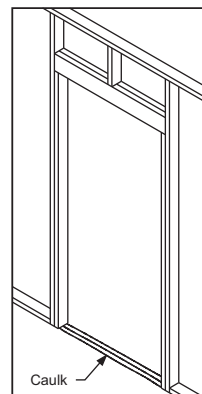
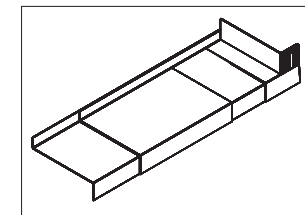
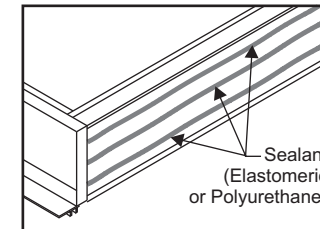

On subfloor at opening, place very large beads of sealant (Elastomeric or Polyurethane) that will match with those placed on sill or sill pan. Run beads full width of opening.

***Avoid callbacks due to leaks!
Use an entire tube of caulking
to seal between sill and subfloor.***

NOTE:

If installing **double or triple units**, place construction adhesive under mullion or point where doors meet at center. Complete installation before adhesive cures.

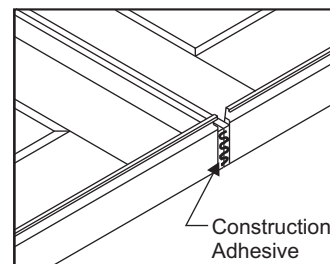
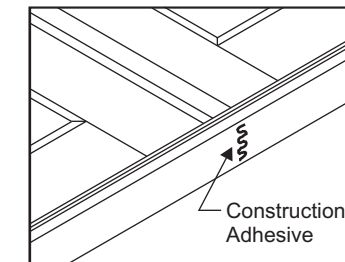

NOTE:

If installing **units with M.E.U.s**, place construction adhesive under points where door jambs will bear on floor. Complete installation before adhesive cures.

9 CAULK FLANGE

Place a generous bead of sealant (Elastomeric or Polyurethane) around entire backside perimeter of flange where it will set against opening.

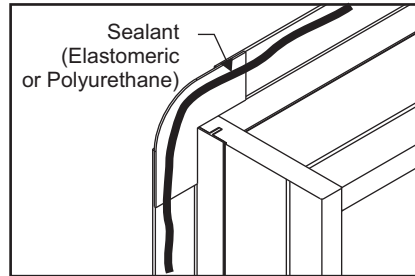

10 PLACE UNIT IN OPENING

From the exterior side of the opening, carefully lift unit up. With top edge tilted away from opening, center unit and place sill down onto caulk beads. Tilt into place. Flange to be flat against opening.

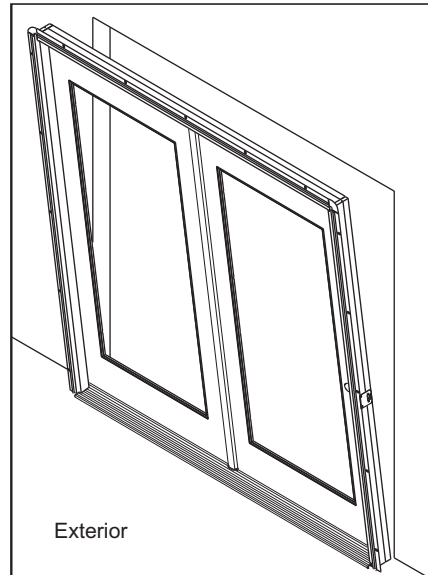

11 FASTEN FLANGE TO OPENING

Check unit for plumb and square.

Fasten unit to opening through holes in flanges using #10 x 3/4" flat head screws.

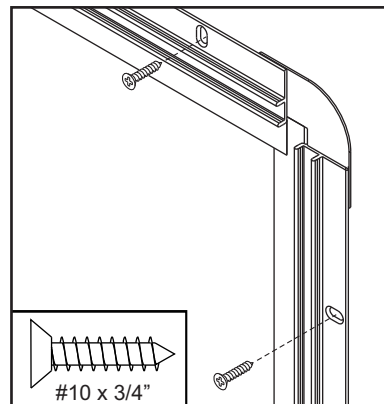

16 SHIM AND SECURE HEAD JAMB - cont.

For Double French Units with Multi-point Lock

Remove screws from head strike plate.

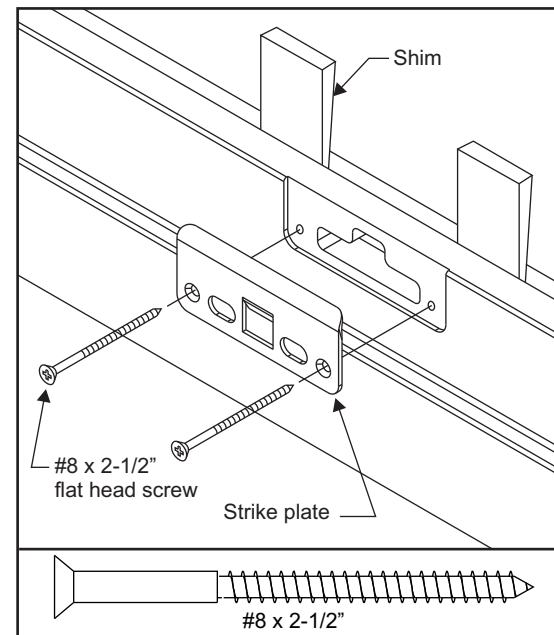
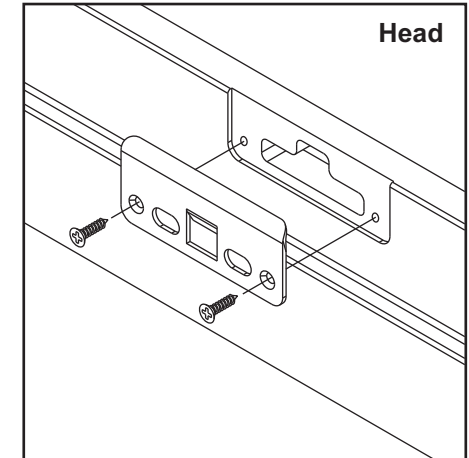

Shim on either side or both sides of strike. Do not shim directly over strike covering hole. This may cause locking mechanism not to completely engage.

Fasten strike with #8 x 2-1/2" flat head screws.

Do not over torque screws to keep jamb from bowing.

15 SHIM AND SECURE INACTIVE JAMB

For Double/Triple and M.E.U. Units

Insert shims on inactive side of jamb, 6" from the top and 12" on center.

Check jamb to ensure it is plumb and straight. Use a 6-foot level.

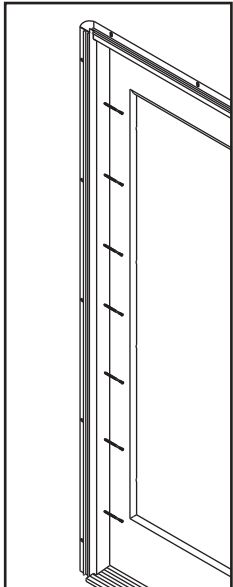
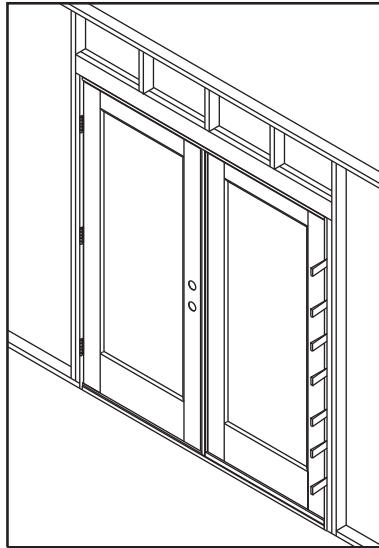

Pre-drill 3/32" dia. pilot holes through jamb at shim locations.

Using (3) #8 x 2-3/4" trim head screws, fasten jamb to opening.

Do not over torque screws to keep jamb plumb and straight.

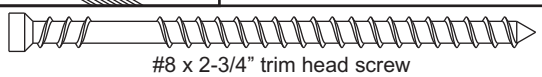

#8 x 2-3/4" trim head screw

16 SHIM AND SECURE HEAD JAMB

For Double French and Double/Triple Units

Place shim between head jamb and opening on both sides of astragal or mullion and 12" on center.

Pre-drill 3/32" dia. pilot holes through frame at shim location.

Fasten with #8 x 2-3/4" trim head screws through frame into header.

Do not over torque screw to keep jamb from bowing.

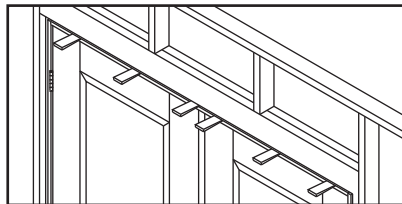

12 REMOVE TRANSPORT CLIP

Unscrew transport clip from jamb and door.

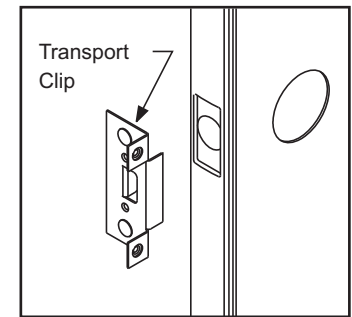

13 SHIM AND SECURE HINGE JAMB

For Single, Double French and Double/Triple Panel Units

Insert shims behind hinges and every 12" on center between jamb and opening to prevent sagging and bowing.

Recheck hinge jamb to ensure it is plumb and straight. Use a 6-foot level.

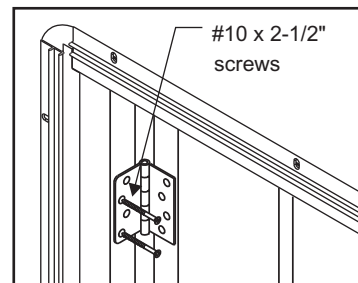
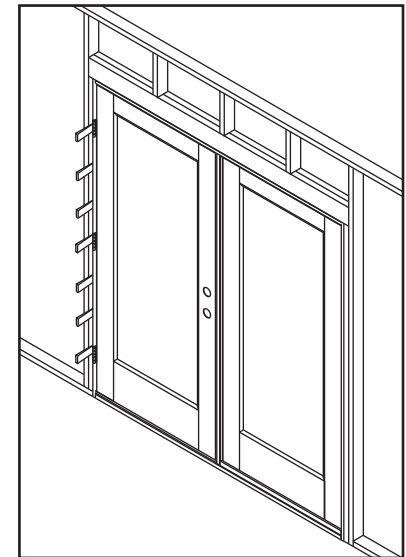

Open door.

Drill 1/8" dia. pilot holes through open holes in top, middle and bottom hinges, drilling through jamb and through flange on outswing units.

Fasten with #10 x 2-1/2" screws through hinges and shims to anchor frame and prevent sagging.

For screws not going through the hinges, drill 3/32" pilot hole and use #8 x 2-3/4" trim head screws.

14 SHIM AND SECURE LOCK JAMB

For Single and Double/Triple Units with Standard Lock Option

Insert shims 6" from top and bottom and 12" on center to prevent sagging and bowing.

Check to ensure jamb is plumb and straight. Use a 6-foot level.

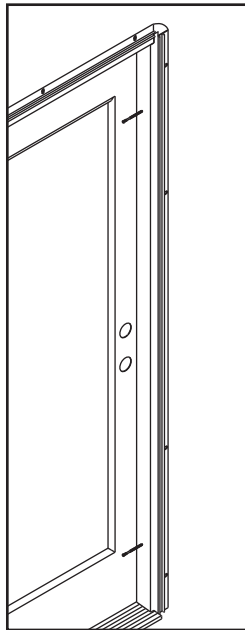
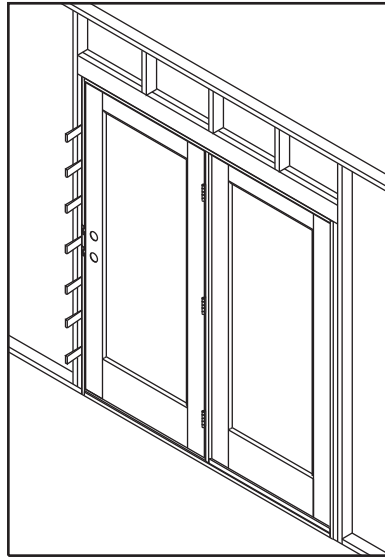

Pre-drill 3/32" dia. pilot holes through jamb at shim locations.

Using (2) #8 x 2-3/4" trim head screws, fasten jamb to opening.

Do not over torque screws to keep jamb plumb and straight.

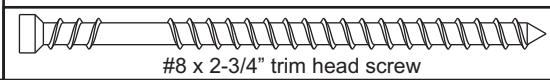

Insert shim behind latch area, open door and drill 3/32" dia. pilot holes and place (2) #8 x 2-1/2" screws through strike mounting holes to secure lock jamb center and provide security. Adjust strike in or out for proper door operation and tighten screws.

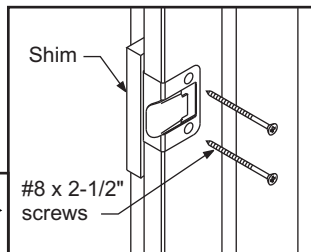
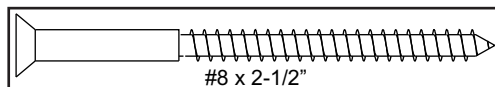

14 SHIM AND SECURE LOCK JAMB - cont.

For Single and Double/Triple Units with Multi-point Lock Option

Open door and remove screws from strike plates.

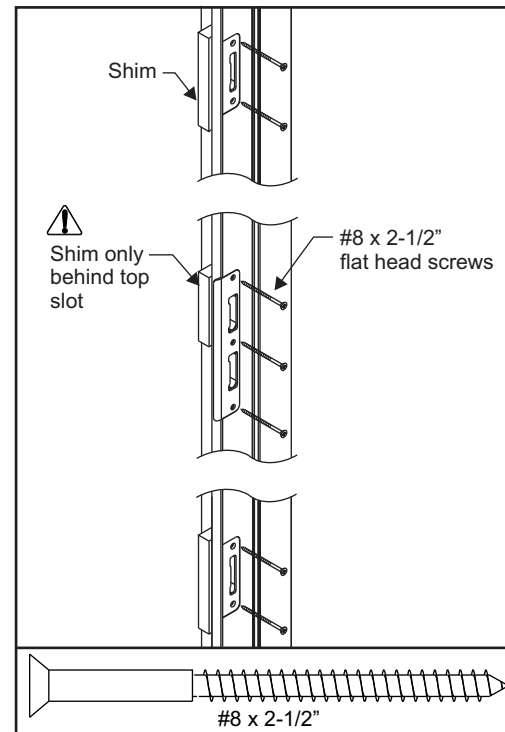
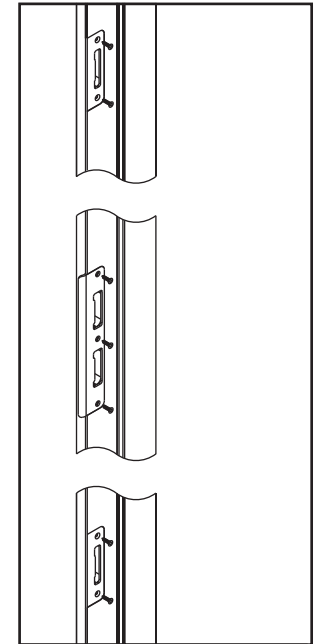

Shim behind top and bottom strikes and behind top slot on middle strike plate.

For outswing units, pre-drill 3/32" dia. pilot holes through flange.

Fasten strikes with #8 x 2-1/2" flat head screws going through shim into opening.

Do not over torque screws to keep jamb plumb and straight.