



DuPont™ Tyvek® ThermaWrap® R5.0 Installation Guidelines for New Construction Using Vinyl, Brick and Stone Claddings

VERSION 1/16

**FOR SINGLE FAMILY HOMES AND LOW RISE MULTI-FAMILY
BUILDINGS LESS THAN 4 STORIES**

DuPont™
Tyvek®
ThermaWrap® R5.0

Table of Contents

Applicable Products	2
Recommended Installation Accessories	2
DuPont™ Recommended Tools*	3
Warranty	3
Code Requirements.....	3
Precautions and Special Considerations.....	3
General Instructions	4
Wall Preparation	6
Installation of Tyvek® ThermaWrap® R5.0	12
Conventional Framed.....	12
Tilt Wall	16
Window Flashing (Flanged Window Installed After WRB)	19
Door Flashing (Brick Mold Door Installed After WRB).....	26
Window Flashing (Flanged Window Installed Before WRB)	35
Door Flashing (Brick Mold Door Installed Before WRB).....	41
Flashing Pipe Penetrations	51
Flashing Electrical Box.....	52
Flashing Dryer Vent	53
Handling Tears and Holes	54
Cladding Installation.....	55
Brick and Stone Installation	57
Cladding Transition	58
Cladding Considerations	59

Applicable Products

Insulating Air and Water-Resistive Barrier

PRODUCT	DIMENSIONS	AREA
DuPont™ Tyvek® ThermaWrap® R5.0	4 ft x 40 ft	160 sq ft

Flashing Products

PRODUCT	DIMENSIONS	AREA
DuPont™ FlexWrap™ NF	6 in x 75 ft 9 in x 75 ft	37.50 sq ft 56.20 sq ft
DuPont™ StraightFlash™	4 in x 75 ft 9 in x 75 ft	25 sq ft 56.25 sq ft
DuPont™ StraightFlash™ VF	6 in x 75 ft	37.5 sq ft
DuPont™ Flashing Tape	4 in x 75 ft 6 in x 75 ft 9 in x 75 ft	18.75 sq ft 37.50 sq ft 56.25 sq ft

Recommended Installation Accessories

PRODUCT	TYPE/DIMENSIONS	QUANTITY
DuPont™ Tyvek® HomeWrap®	3 ft x 100 ft	300 sq ft
DuPont™ Tyvek® Tape	2 in Bulk Pack 3 in Bulk Pack	36 rolls/case 24 rolls/case
DuPont™ Tyvek® Wrap Caps for Stinger Cap Stapler	16 gauge; available in 7/8", 1-1/4", and 1-1/2" lengths	2000 per box
DuPont™ Wrap Cap Nails	1" electro-galvanized ring shank nail	2000 per box
Other manufacturers' cap staples and cap nails	3/4" minimum length	
DuPont™ Adhesive/Primer		
DuPont™ Window and Door Foam		
DuPont™ Residential Sealant		
DuPont™ Insulated Batten	3 in x 4 ft	24/box
DuPont™ Insulated Batten CT	5.8 in x 4 ft	11/box
min. 3" 10d common nails for installing DuPont™ Insulated Battens		

DuPont™ Recommended Tools*

Stinger CS150 Cap Stapler

Stinger CN100 Cap Nailer

DuPont™ Vinylign™ Nail Depth Regulator

WISS Scissor – W10TM

Olfa 60mm rotary cutter

Standard carpet knife

*Use or apply per manufacturers' guidelines. For non-DuPont products, DuPont assumes no liability in use of recommended products; installers need to evaluate suitability of recommended products in their end-use applications.

Warranty

Please see warranty requirements for DuPont™ Tyvek® ThermaWrap® R5.0 at www.weatherization.tyvek.com.

Code Requirements

DuPont™ Tyvek® ThermaWrap® R5.0 meets ICC-ES AC-38 Water-Resistive and Air-Barrier Requirements. ICC-ES Evaluation Report ESR 3545.

DuPont™ Tyvek® ThermaWrap® R5.0 provides continuous exterior insulation when installed as directed.

To achieve a continuous insulation value of R5.0, the DuPont™ Insulated Batten and the DuPont™ Insulated Batten CT must be used where directed.

See DuPont™ Tyvek® ThermaWrap® R5.0 Physical Properties Data Sheet and Insulation Fact Sheet for additional information.

Precautions and Special Considerations

Although normal handling of DuPont™ Tyvek® ThermaWrap® R5.0 requires no special Personal Protective Equipment (PPE), DuPont recommends appropriate job site PPE in accordance with OSHA and site standards during installation of the product.

DuPont™ Tyvek® ThermaWrap® R5.0 is combustible and should not come into contact with open flame or other high heat sources. Clearances around fireplaces, hot pipes, etc. should follow the National Fire Protection Agency (NFPA) and local code requirements. For more information about the combustibility of DuPont™ Tyvek® products, refer to the last page of this document.

General Instructions

DuPont™ Tyvek® ThermaWrap® R5.0 Installation

- A Certified Installer training program is available for the installation of Tyvek® ThermaWrap® R5.0. Certification is not required to install DuPont™ Tyvek® ThermaWrap® R5.0; however, installers should read and adhere to all steps of these installation guidelines.
- DuPont™ Tyvek® ThermaWrap® R5.0 is not intended for open stud construction.
- All windows and doors must be installed on the same plane as the DuPont™ Tyvek® ThermaWrap® R5.0 outer layer.

The best time to install DuPont™ Tyvek® ThermaWrap® R5.0 is:

- After the roof sheathing is installed
- After the step flashing and kick out flashing have been installed
- **BEFORE** the windows are installed

When installing DuPont™ Tyvek® ThermaWrap® R5.0

- A larger brick/stone ledge may be required to accommodate the 1-1/2" thickness of the DuPont™ Tyvek® ThermaWrap® R5.0.
- Extension jambs may be required around the interior of the windows. This product may also affect the appearance of the window sill corners.
- All insulation edges must butt tightly against one another to help maintain continuous insulation.

A feature of the DuPont™ Tyvek® ThermaWrap® R5.0 is that the insulating fibers can be torn vertically. This eliminates the need for cutting the fibers in such areas as flap creation and window opening preparation.

During installation of DuPont™ Tyvek® ThermaWrap® R5.0, an uninsulated Tyvek® flap may be required to ensure shingling for proper water management. To create a flap, separate the insulation from the Tyvek® membrane a minimum of 6". Fold back the Tyvek® layer. Cut or tear to remove the insulation. Do not damage the Tyvek® layer.

It may not be necessary to install DuPont™ Tyvek® ThermaWrap® R5.0 on gable ends to meet energy codes. If DuPont™ Tyvek® ThermaWrap® R5.0 is not installed on the gables, use Tyvek® HomeWrap®. Additional furring may be required in order for all cladding to be on the same plane. Check local building codes for additional information.

It is essential to maintain the continuity of the water-resistive barrier from top to bottom including proper shingling with sufficient lapping. Continue wrapping all the way up the structure, overlapping the previous layer of DuPont™ Tyvek® ThermaWrap® R5.0 top sheet by a minimum of 6".

Lap DuPont™ Tyvek® ThermaWrap® R5.0 top sheet over all flashing (e.g. step flashing, wall to roof intersections and through wall flashings).

DuPont™ Insulated Batten

For optimal thermal performance and to achieve a continuous insulation value of R5.0, the DuPont™ Insulated Batten and the DuPont™ Insulated Batten CT are to be installed into framing members. The DuPont™ Insulated Batten CT is designed to be used as a nail base at all inside and outside corners, around windows and doors, penetrations, wall to roof intersections and at areas on the structure where cladding accessories such as shutters and decorative trim are installed.

NOTE: It is acceptable to use nominal 2" thick lumber in place of the DuPont™ Insulated Batten CT. It is NOT acceptable to use substitutes for the DuPont™ Insulated Batten in the field of the wall.

- The foam portion of the battens is to be installed against the wood sheathing.
- The DuPont™ Insulated Batten CT can be ripped if the full width is not required.

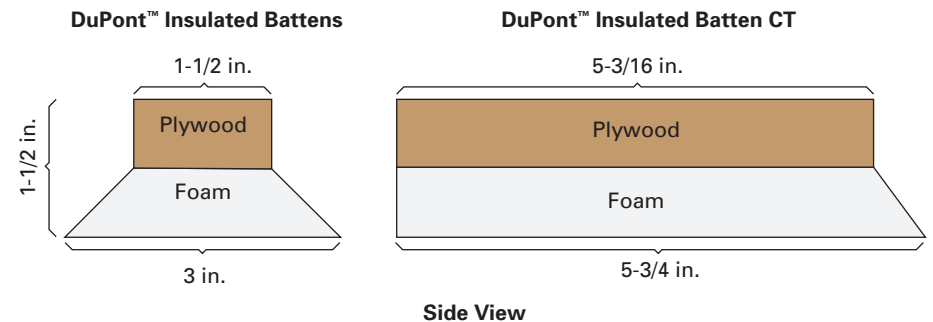

For use with lap siding, see *DuPont™ Tyvek® ThermaWrap® R5.0 Installation Guidelines for New Single Family Houses Using Lap Siding*. K-27304.



DuPont™ Tyvek® ThermaWrap® R5.0 Installation Guidelines

DuPont Flashing Systems Installation

DuPont™ Flashing Systems products should be installed on clean, dry surfaces that are free of frost. Wipe surfaces to remove moisture, dirt, grease and other debris that could interfere with adhesion.

Adverse weather conditions or cold temperatures may require the use of a primer to promote adhesion of DuPont Flashing Systems Products to most building materials. Concrete and masonry require the use of DuPont™ Adhesive/Primer.

Apply pressure along entire surface of flashing for a good bond using a J-roller or firm hand pressure.

Remove all wrinkles and bubbles that may allow for water intrusion by smoothing surfaces and repositioning as necessary.

When flashing the sill area for windows and doors, DuPont recommends the use of 6" wide DuPont™ Flexwrap™ NF for 2" x 4" framing and 9" wide DuPont™ Flexwrap™ NF for 2" x 6" framing. As an option, if a rigid back dam is desired, cut to the length of the sill and nail into place on the interior edge of the sill prior to installation of DuPont™ Flexwrap™ NF. Then install DuPont™ Flexwrap™ NF over sill and corner guard back dam. If using 6" DuPont™ FlexWrap™ NF with optional rigid back dam, seal ends of corner guard with DuPont™ Residential Sealant, or other recommended sealant.

Door and window rough sill framing must be level or slightly sloped to the exterior to ensure proper drainage to the exterior. This best practice ensures continuous support with positive slope to the exterior.

DuPont™ Residential Sealant should be tooled flat to allow the natural curing process to create a concave joint.

Sealants

If a sealant other than DuPont™ Residential Sealant is used, apply per manufacturers' guidelines.

DuPont assumes no liability in use of non DuPont products; installers need to evaluate suitability of these products in their end-use applications. Review the sealant manufacturers' literature or label to confirm that the product used has the chemical and adhesive properties necessary for use with DuPont™ Tyvek® air and water barriers and DuPont flashing materials. Refer to *Chemical Compatibility of Representative Building Sealants* (K-27282) for more information about chemical compatibility

Wall Preparation

STEP 1 – BUMP OUT FRAME INSTALLATION

Install a bump-out frame around all windows and door openings before installing DuPont™ Tyvek® ThermaWrap® R5.0. For optimal thermal performance, the DuPont™ Insulated Batten CT is recommended. Standard nominal 2" thick lumber is acceptable. Wider Bump-out frames may be required to accommodate window and door trim. Cut the frame pieces so they create vertical seams at the sill and horizontal seams at the head (the sill piece should be the width of the rough opening. The jamb pieces should extend to the top of the rough opening and the head piece should extend to the outside of the jamb pieces.)

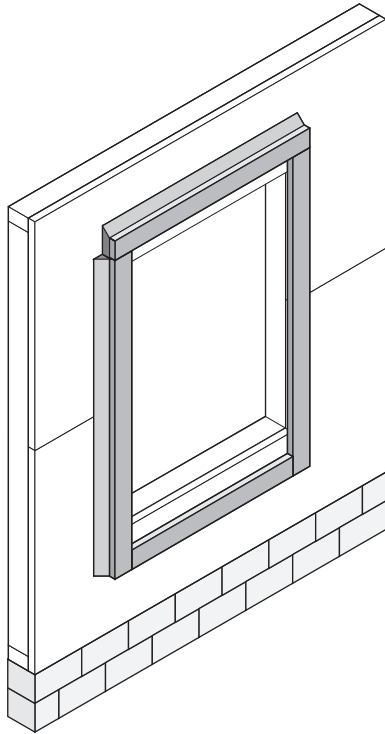

STEP 2 – BOTTOM OF WALL DETAIL

Brick and Stone Installations

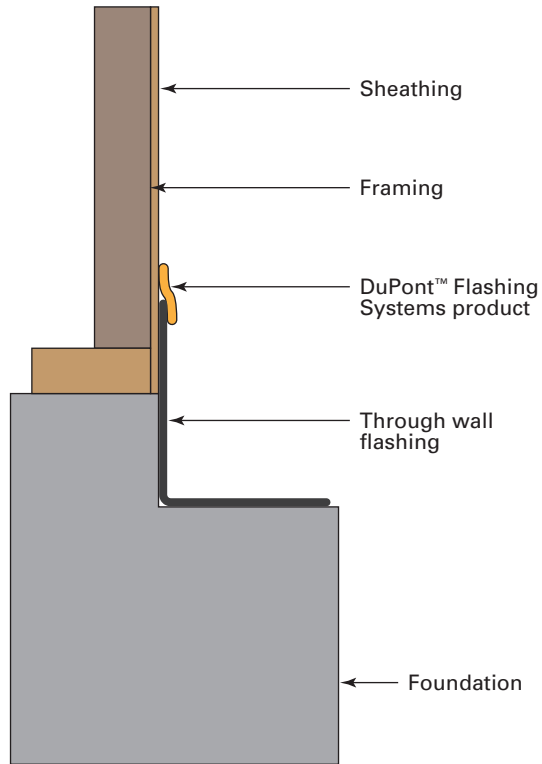

Vinyl Siding Installations

Along the sill plate, install a min. 4" wide piece of DuPont™ Flashing System product around the perimeter of the home. 1" should extend on to the foundation. DuPont recommends the installation of termination accessories such as a bump-out or termination ledge along the sill plate and at roof to wall intersections. A nominal 2" thick bump-out will provide added support for a cladding starter strip. For optimal thermal performance, the DuPont™ Insulated Batten CT is recommended. The square edge should be directed to the bottom of the wall. Standard 2 x 3's and 2 x 4's are acceptable. Fasteners must penetrate framing member a min. 1". If an accessory is not used, proceed to step 4.

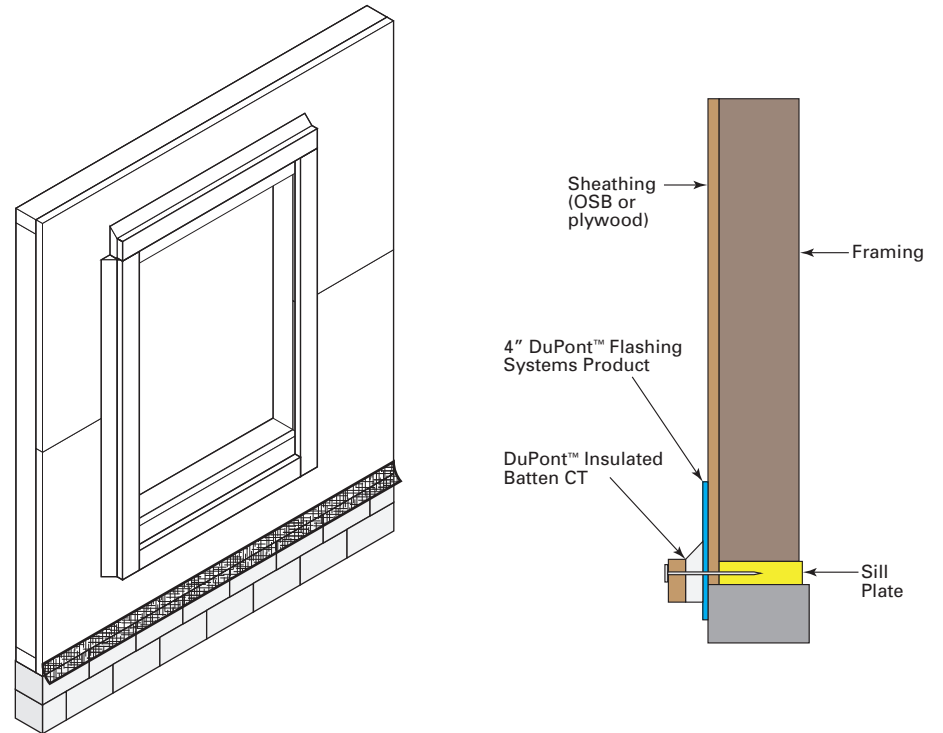

DuPont™ Tyvek® ThermaWrap® R5.0 Installation Guidelines

Alternative Bottom of Wall Details

Termination Ledge – Must be wide enough to protect bottom edge of Tyvek® ThermaWrap® R5.0. Termination Ledge will not provide support for cladding starter strip.

If there is a concern about water infiltration behind Tyvek® ThermaWrap® 5.0, one option is to replace the 4" piece of DuPont self-adhered flashing product behind the bump out with a piece of 9" DuPont™ Flashing Tape. In addition to protecting the exposed surface of the bump out, this piece of flashing will protect bottom 2-1/2" of sheathing.

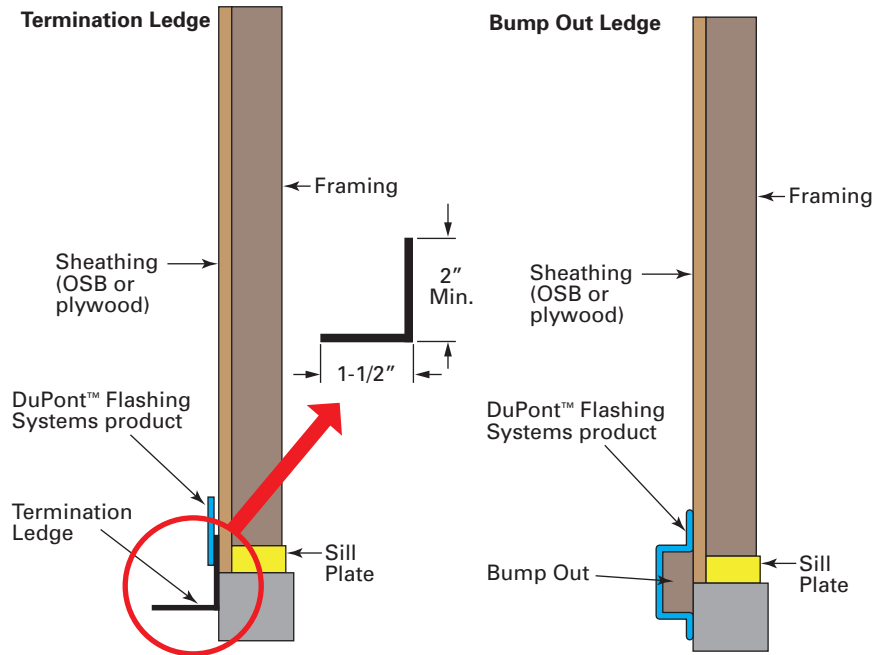

STEP 3 – TOP OF WALL, ROOF-TO-WALL, LEDGER BOARD DETAILS

Using the DuPont™ Insulated Batten and the DuPont™ Insulated Batten CT, install a bump-out at the top of the wall, roof to wall intersections and all ledger board locations. Each batten is to be secured into the stud using a min. 3" long framing nail. Secure each batten 2" from each end and every 10-12" in the field. See details on pages 9-11. Standard nominal 2" thick lumber such as a 2x4 is acceptable.

STEP 3A – TOP OF WALL DETAILS

Common Truss

Before the installation of the DuPont™ Tyvek® ThermaWrap® R5.0, install a bump out at the top of the wall. For optimal thermal performance, a DuPont™ Insulated Batten or DuPont™ Insulated Batten CT is recommended. A standard nominal 2" thick lumber such as a 2x4 is acceptable.

DuPont™ Tyvek® ThermaWrap® R5.0 should overlap batten 1-2" at the top. At the overlap, separate Tyvek® from insulation to create a flap. Tuck excess insulation along the bottom edge of the batten. Secure flap with cap fastener and Tyvek® Tape or a DuPont™ Flashing System product.

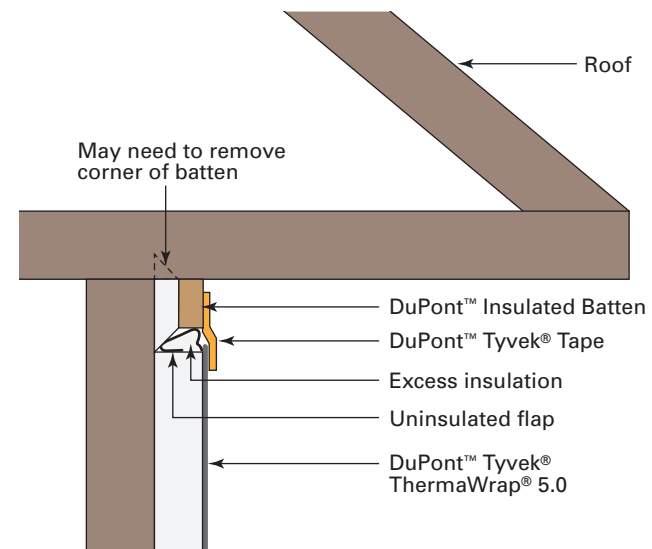

DuPont™ Tyvek® ThermaWrap® R5.0 Installation Guidelines

Raised Heel Truss

Before the installation of the DuPont™ Tyvek® ThermaWrap® R5.0, install a bump out at the top of the wall. For optimal thermal performance, a DuPont™ Insulated Batten or DuPont™ Insulated Batten CT is recommended. A standard nominal 2" thick lumber such as a 2x 4 is acceptable. The batten should be installed to accommodate soffit installation. DuPont™ Tyvek® ThermaWrap® R5.0 should overlap the batten at the top 1-2". At the overlap, separate Tyvek® from insulation to create a flap. Tuck excess insulation along the bottom edge of the batten. Secure flap with cap fastener and DuPont™ Tyvek® Tape or a DuPont™ Flashing Systems product.

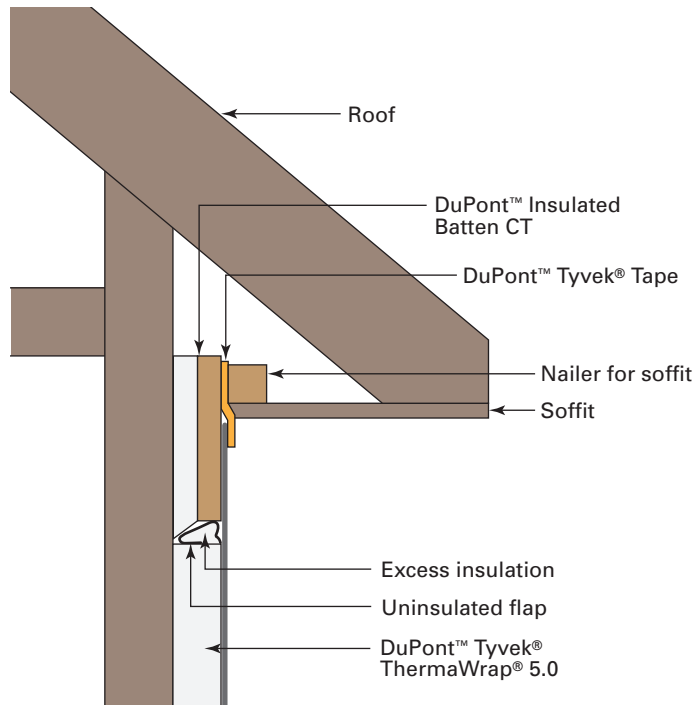

Gable

Before the installation of the DuPont™ Tyvek® ThermaWrap® R5.0, install a DuPont™ Insulated Batten CT. The square edge should align with the edge of the roof. This is to accommodate rake board. DuPont™ Tyvek® ThermaWrap® R5.0 should overlap the DuPont™ Insulated Batten CT at the top 1-2". At the overlap, separate Tyvek® from insulation to create a flap. Tuck excess insulation along the bottom edge of the DuPont™ Insulated Batten CT. Secure flap with cap fastener and Tyvek® Tape.

NOTE: A nominal 2" thick bump-out can be used if the attic is unconditioned. For example, use 2 x 4 as a bump-out for a 2x 6 or 2 x 8 rake board.

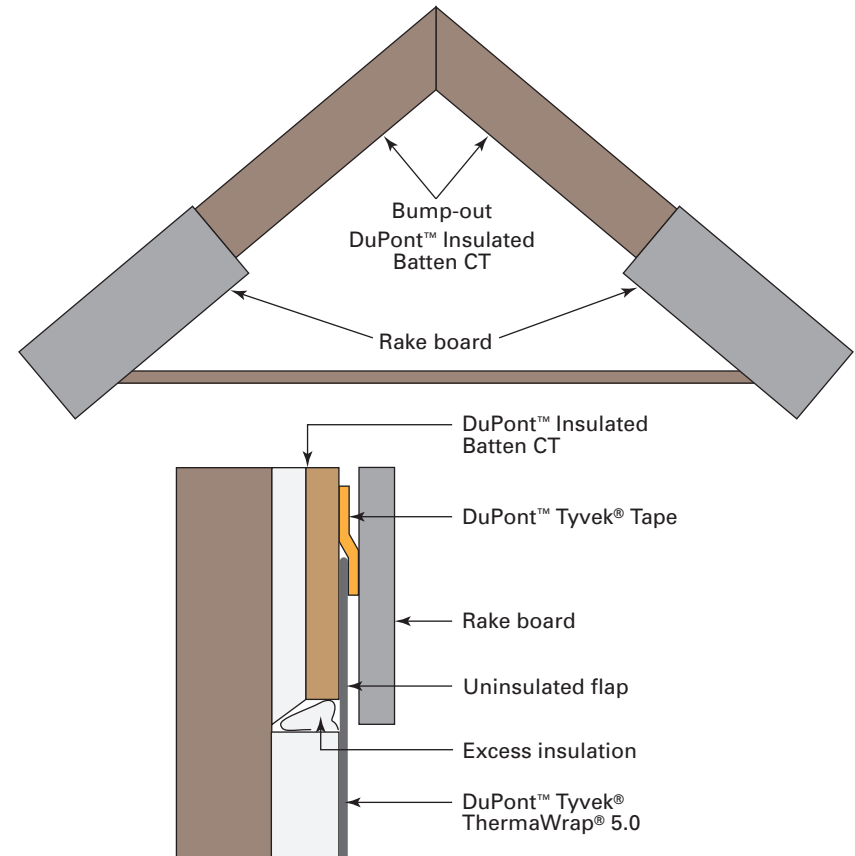

DuPont™ Tyvek® ThermaWrap® R5.0 Installation Guidelines

STEP 3B – WALL TO ROOF INTERSECTIONS

Bump-out should be installed after step flashing. Bump-out must be installed a minimum of 2" above the roof surface. For optimal thermal performance, the DuPont™ Insulated Batten CT is recommended. The square edge should be directed to the bottom of the wall. Standard 2 x 3's and 2 x 4's are acceptable. See page 15 for proper termination of Tyvek® ThermaWrap® R5.0 at base of wall.

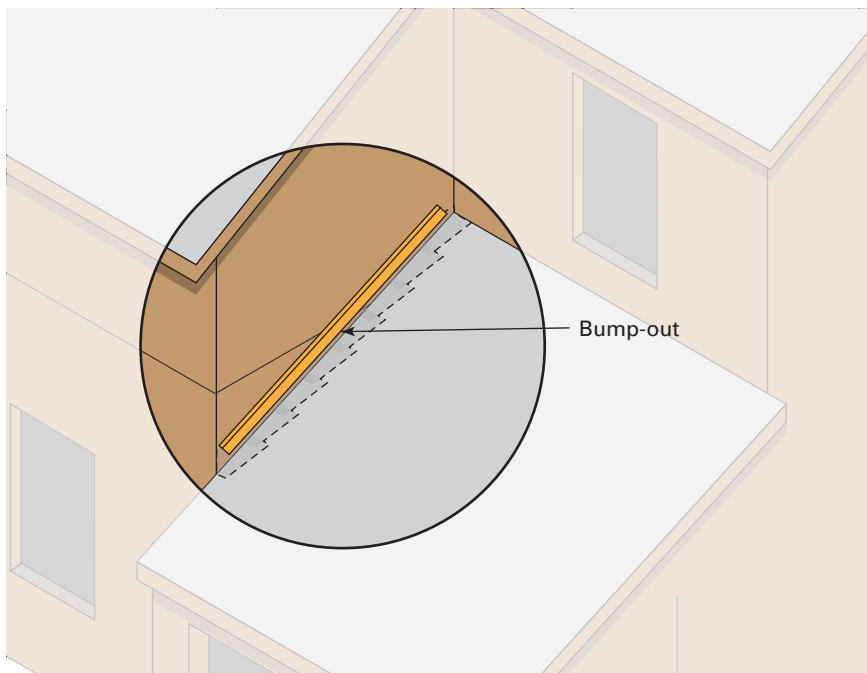

STEP 3C – LEDGER BOARD DETAIL

Make necessary cuts in the ThermaWrap® R5.0 and install appropriate step or through wall flashing ensuring a minimum 6" overlap. Tape DuPont™ Tyvek® ThermaWrap® R5.0 to flashing using Tyvek® Tape.

DuPont is a manufacturer of weatherization products and therefore is not responsible or liable for building design or structural performance.

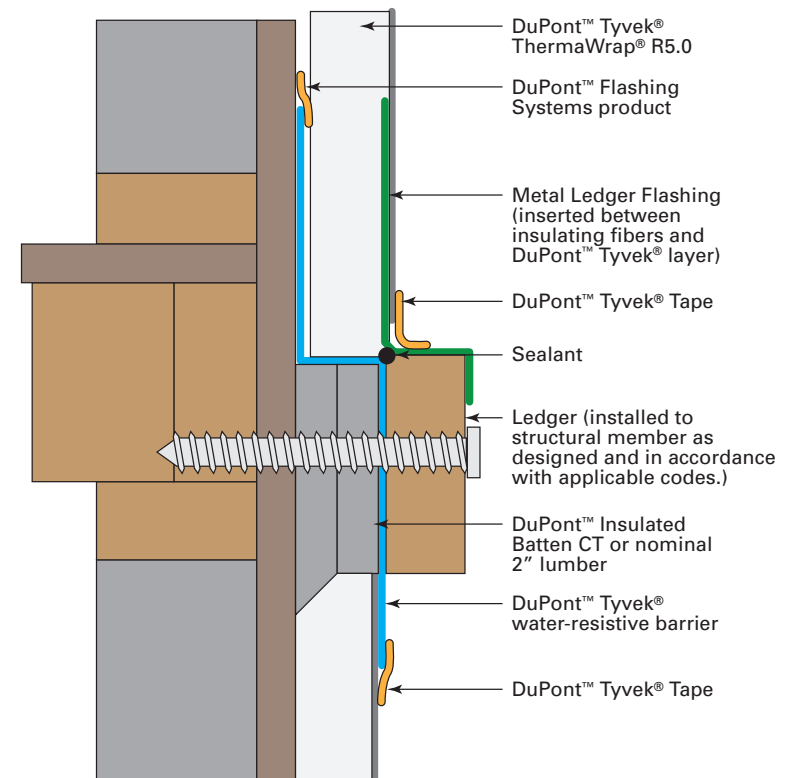

DuPont™ Tyvek® ThermaWrap® R5.0 Installation Guidelines

STEP 4 – BUMP-OUT FLASHING

- A. Install a 4" x 4" piece of DuPont™ FlexWrap™ NF at both upper corners of the bump-out frame. Install 2-3 inches on the wood sheathing and ensure the DuPont™ FlexWrap™ NF extends to the edge or overlaps on to the face of the bump-out frame.
- B. Install DuPont™ Flashing Systems product at the intersection of the wood sheathing and DuPont™ Insulated Batten CT (bump-out frame) at all windows. Cut a piece the width of the DuPont™ Insulated Batten CT (bump-out frame).

NOTE: DuPont™ Flashing Systems Product must protect the foam and wood edge of the DuPont™ Insulated Batten CT (bump-out frame).

For round top windows, use DuPont™ FlexWrap™ NF. Install 2-3 inches on the wood sheathing and continue along the top edge of bump-out frame.

OPTION: Use a wider DuPont™ Flashing Systems product to integrate with window flashing.

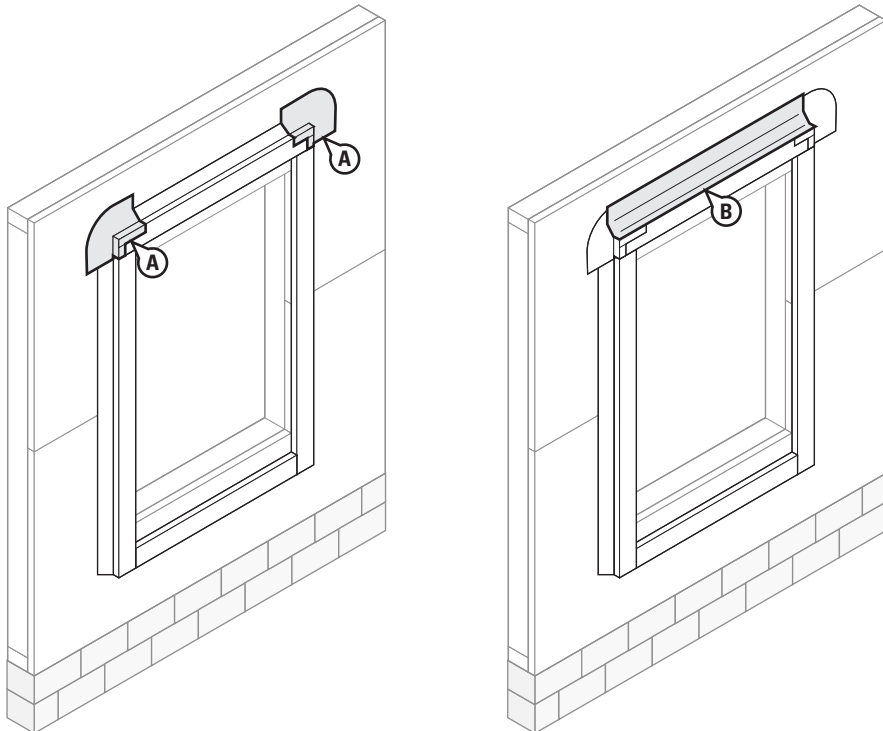

STEP 5 – CREATING A GUIDE

Using a chalk line, create a guide for installing the first course of DuPont™ Tyvek® ThermaWrap® R5.0.

- If using a DuPont™ Insulated Batten CT or nominal 2" wood bump-out, create a line around the building 4 ft. above the top of the bump-out.
- If using the termination ledge, create a line around the building 4 ft. above the bottom edge of the strip.
- If a bottom detail is not used, the line should be 47" above the bottom of the sill plate.

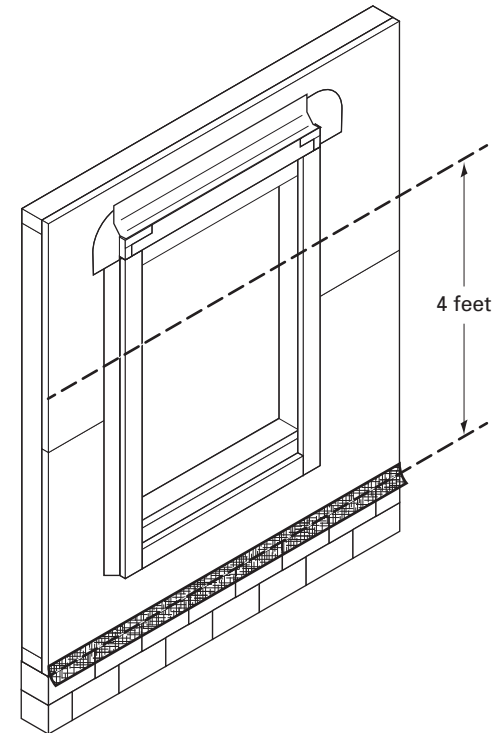

Installation of Tyvek® ThermaWrap® R5.0

These guidelines cover the installation of Tyvek® ThermaWrap® R5.0 installed on Conventional Framed structures and Tilt Wall Framed structures. To maintain proper shingling, DuPont™ Tyvek® ThermaWrap® R5.0 can only be installed horizontally. See page 16 for installation over Tilt Wall Framed structures.

Unroll directly over windows and doors. For larger window and door openings, an option is to cut the material at the right jamb and move the roll and start again at the left jamb. This will eliminate the waste that is normally cut from the window opening. When using this method, the Tyvek® ThermaWrap® R5.0 must be cut so that there is enough material to wrap into the interior of the window or door opening and secured to the inside of the wall as shown on page 21. On walls that have multiple window and door openings, another option is to pre-cut pieces of Tyvek® ThermaWrap® R5.0 to fit between the openings. Again, the Tyvek® ThermaWrap® R5.0 must be cut long enough to extend into the window opening and be secured.

Don't leave window openings covered overnight. Prepare the window openings as shown on step 1 on page 19. This allows air to pass through the opening and prevents the potential for blow-off or damage to the Tyvek® ThermaWrap® R5.0

Conventional Framed

Start at the bottom of the structure to ensure proper shingling throughout the installation. Proper shingling is required to shed water and to prevent water from entering the wall system.

STEP 1 – UNROLLING TYVEK™ THERMAWRAP® R5.0

Starting at a corner of the building, align the vertical edge of insulation with the edge of the building and begin unrolling Tyvek® ThermaWrap® R5.0 from right to left. Ensure insulation material is against the wall sheathing. Do not secure the 6" Tyvek® flap at the beginning of the roll. Use the chalk line on the wall as a guide for the top edge. Unroll directly over window and door openings. **DO NOT INSTALL INSULATION UPSIDE DOWN. DO NOT STRETCH OR PULL MATERIAL TIGHT AGAINST WALL SHEATHING INCLUDING INSIDE AND OUTSIDE CORNERS.** Tension on the Tyvek® ThermaWrap® R5.0 will reduce the thickness and R-value.

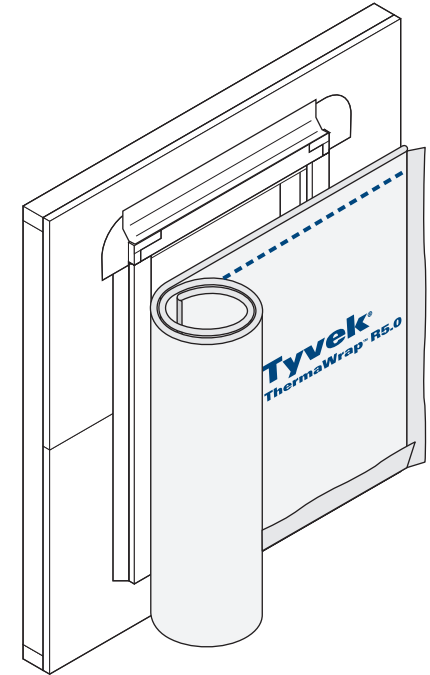

DuPont™ Tyvek® ThermaWrap® R5.0 Installation Guidelines

STEP 2 – FASTENING TYVEK® THERMAWRAP® R5.0

Along the top edge of the roll, there is an area for fastening. On the dashed line, attach the DuPont™ Tyvek® ThermaWrap® R5.0 every 16" using:

- DuPont™ Tyvek® Wrap Cap Staples for Stinger
- DuPont™ Tyvek® Wrap Cap nails for Stinger or DuPont recommended cap fastener

NOTE: Do not fasten within 9" of bump-outs

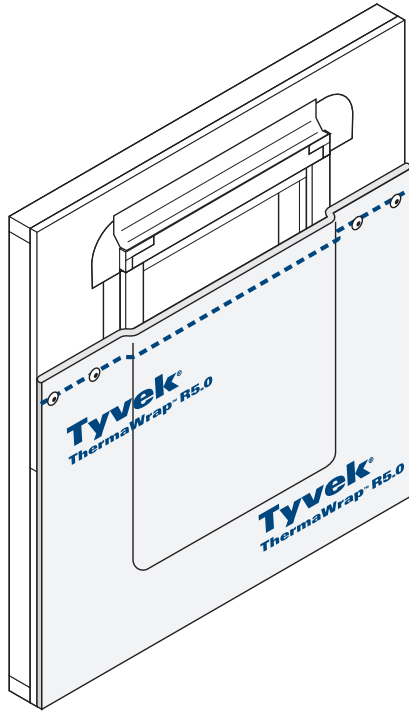

STEP 3

Install first roll of Tyvek® ThermaWrap® R5.0. Continue around the structure installing the next roll making sure the vertical edge of the insulation butts against the vertical edge of the previous roll.

STEP 4

Continue to unroll the product around the structure until the first course is complete. Cut the Tyvek® ThermaWrap® R5.0 1-1/2" beyond corner of the structure.

STEP 5

Install the next and subsequent courses the same as the first. Ensure the bottom edge of the insulation butts against the top edge of the prior course.

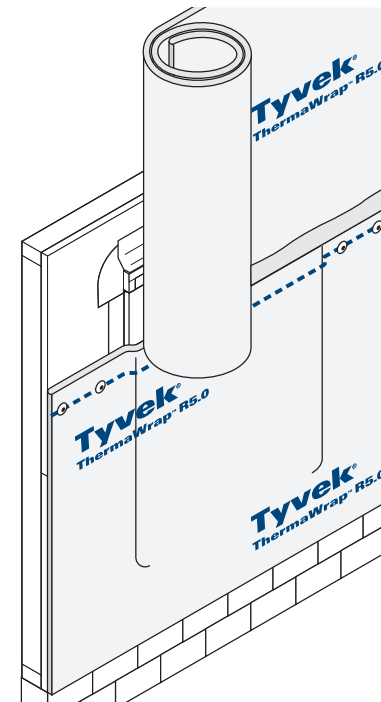

DuPont™ Tyvek® ThermaWrap® R5.0 Installation Guidelines

STEP 6 – TERMINATING TYVEK® THERMAWRAP® R5.0

Fold horizontal and vertical flaps and tape all seams with 2" DuPont™ Tyvek® Tape. Seal the bottom edge using the details on pages 14-15.

NOTE: The bottom edge should NOT be sealed until all Tyvek® ThermaWrap® R5.0 has been installed and all other seams have been taped, including the top of the wall detail. This will ensure that precipitation does not collect behind the product during the installation process. Once Tyvek® ThermaWrap® R5.0 has been fully and properly installed and the bottom edge sealed, bulk water will not collect behind the product.

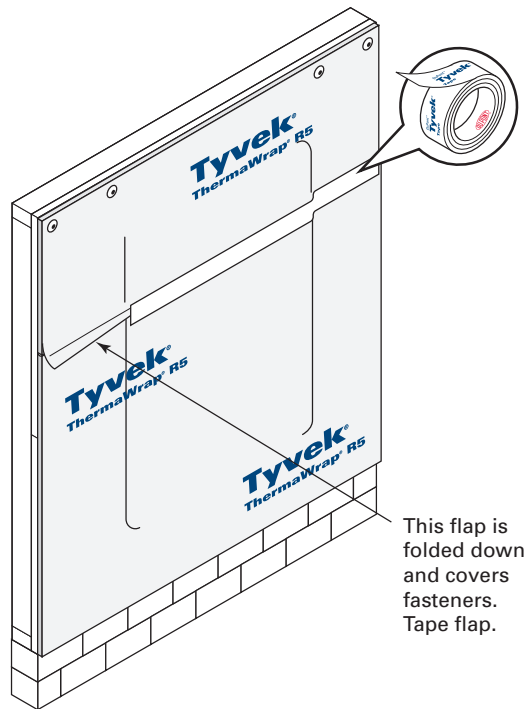

Brick and Stone Installation

- Terminate the uninsulated Tyvek® flap to the through wall flashing with 2" DuPont™ Tyvek® Tape

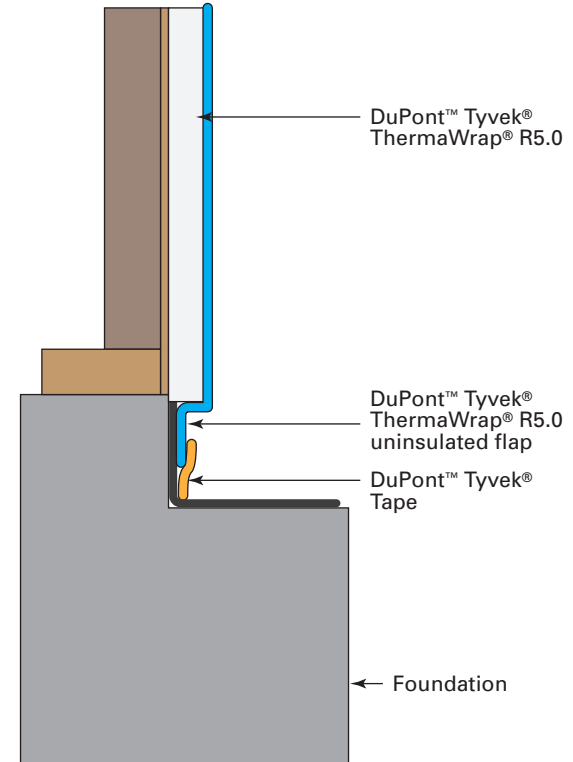

DuPont™ Tyvek® ThermaWrap® R5.0 Installation Guidelines

Vinyl Siding Installations

- If using a DuPont™ Insulated Batten CT or nominal 2" bump-out at the base of the wall, terminate the bottom uninsulated Tyvek® flap. Trim the flap flush with the bottom edge of the DuPont™ Insulated Batten CT. Secure the flap with 3" DuPont™ Tyvek® Tape or a DuPont™ Flashing Systems product. The DuPont™ Flashing Systems product or the 3" DuPont™ Tyvek® Tape must terminate on the DuPont™ Flashing Systems product secured to the wall and foundation.

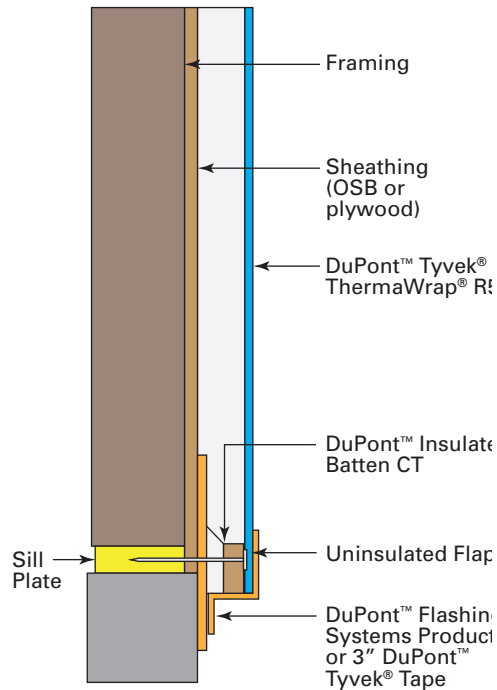

- If using the termination ledge, remove the uninsulated Tyvek® flap at the bottom and secure to the termination strip with a DuPont™ Flashing Systems product or DuPont™ Tyvek® Tape.

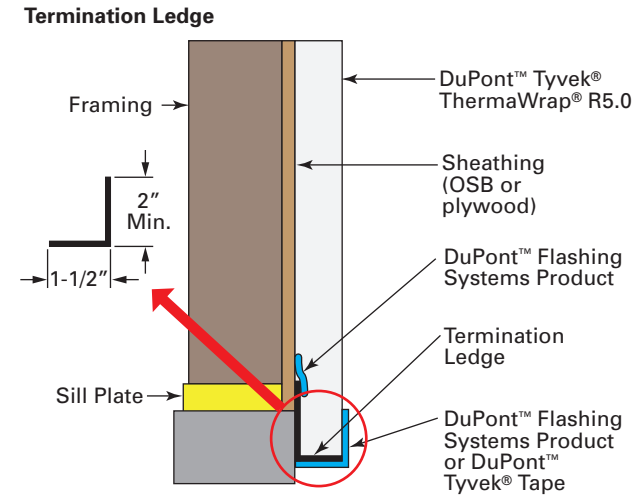

- If a termination accessory is not used, seal the flap at the bottom of the wall with a DuPont™ Flashing Systems product, DuPont™ Tyvek® Tape, or DuPont™ Residential sealant. The uninsulated Tyvek® flap should cover the bottom edge of insulation before turning down onto the foundation.

Tilt Wall

First Floor

STEP 1

Provide enough insulation to overhang the bottom edge of the wall so that the bottom of the wall termination can be completed when the wall is tilted upright. Be sure to include material for rim board.

Determine the amount of material overhanging and subtract this distance from the width of a roll of Tyvek® ThermaWrap® R5.0 (4 ft.). Strike a chalk line this distance above the bottom edge of the wall. There are "UP" arrows printed on the Tyvek® top sheet. Starting at the edge of the wall unroll the Tyvek® ThermaWrap® R5.0 so the "UP" arrows will point upwards to the top of the wall after the wall is tilted. Leave a minimum of 6" flap at the beginning. This may require the creation of a flap.

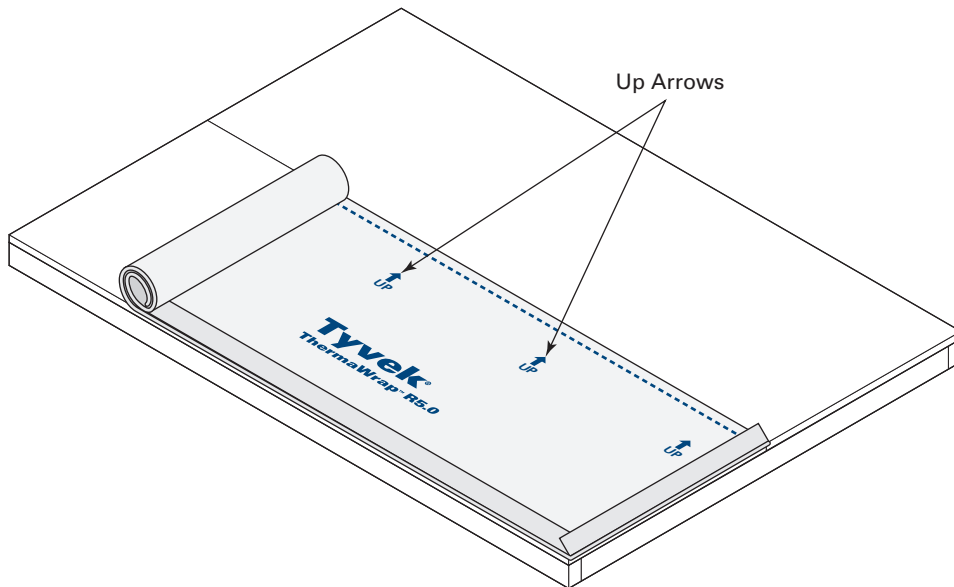

STEP 2

At window and door openings, cut the DuPont™ Tyvek® ThermaWrap® R5.0 on the first side long enough to extend to the back of the window opening. Separate insulation from Tyvek® back to the outside edge of the bump out frame. Cut or tear insulation along outside edge of bump out frame. Fold Tyvek® flap into window opening. Do the same for the other side of the opening.

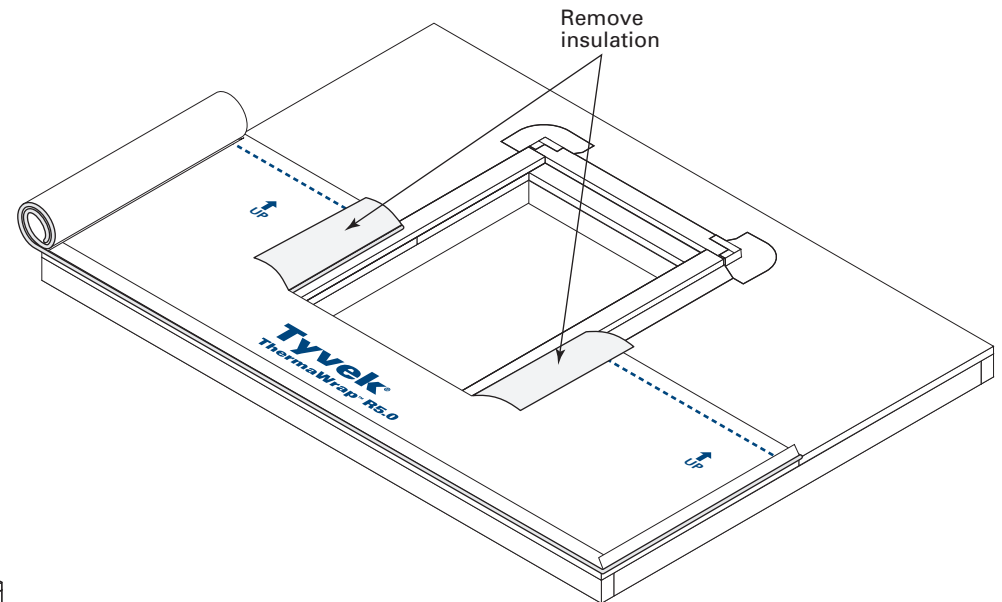

DuPont™ Tyvek® ThermaWrap® R5.0 Installation Guidelines

STEP 3

At the end of the panel, cut the Tyvek® ThermaWrap™ R5.0 flush with the edge of the wall. At all corners, leave additional ThermaWrap® R5.0 to accommodate thickness of framing and Tyvek® ThermaWrap® R5.0 on adjacent wall. Secure on the dashed line along the top edge into every stud.

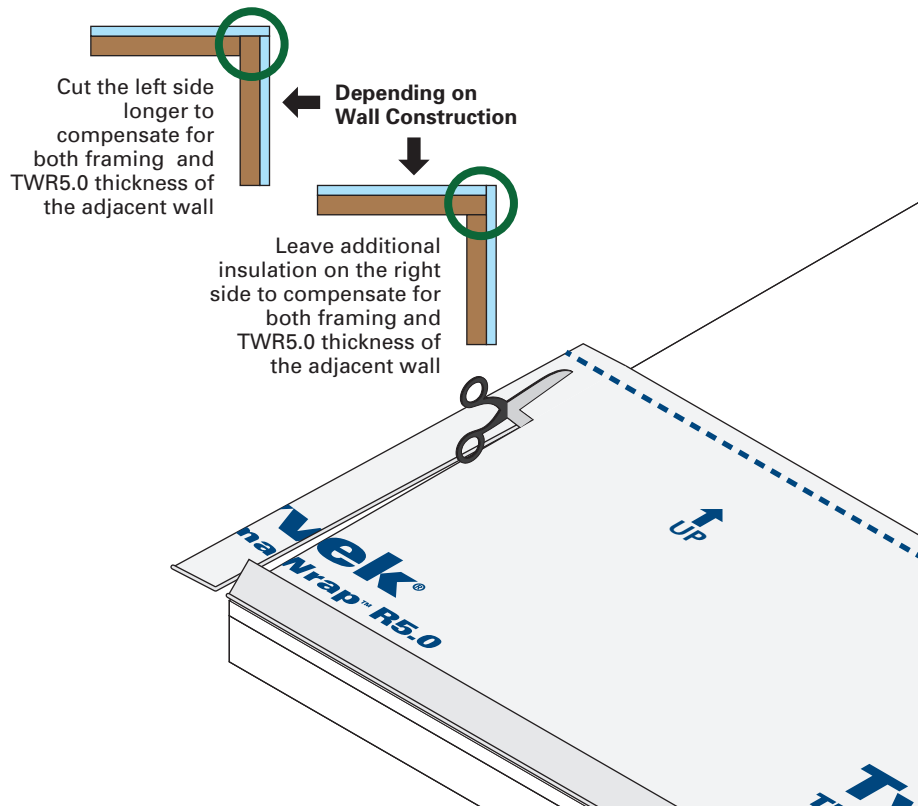

STEP 4

Install the 2nd course the same as the first course.

STEP 5

For single story structures, unroll 3rd course, fasten along top edge and cut off excess. For multiple story structures, it's not necessary to install a 3rd course at this time.

STEP 6

Fold back any material hanging over the bottom edge of the wall. This will prevent the material from getting pinched when the wall is raised.

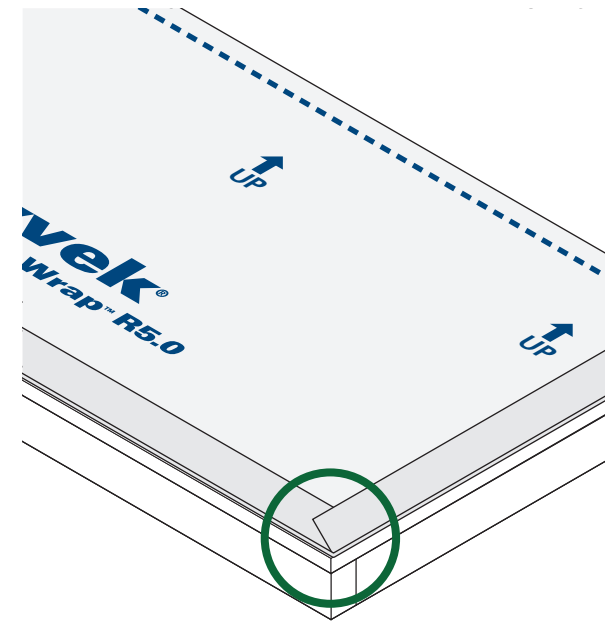

STEP 7

As each wall section is raised, ensure the bottom of the insulation butts against the termination accessory or overlaps the sill plate.

DuPont™ Tyvek® ThermaWrap® R5.0 Installation Guidelines

Second Floor and above

STEP 8

For multiple story structures, or sides with gables, the exposed sheathing can be covered when the DuPont™ Tyvek® ThermaWrap® R5.0 is installed on the second and successive stories or gables. When installing the DuPont™ Tyvek® ThermaWrap® R5.0 on the story above the exposed sheathing, measure the amount of exposed sheathing below. Be sure to include the rim board. Subtract this amount from 4 ft. and strike a chalk line this distance from the bottom of the second story wall or gable. Install the top edge of DuPont™ Tyvek® ThermaWrap® R5.0 along this line.

STEP 9

Fold back the material hanging over the wall. This will prevent the material from getting pinched when the wall is tilted.

STEP 10

Fold horizontal and vertical flaps and tape all seams with 2" DuPont™ Tyvek® Tape. Seal the bottom edge using the below steps.

NOTE: The bottom edge should NOT be sealed until all Tyvek® ThermaWrap® R5.0 has been installed and all other seams have been taped, including the top of the wall detail. This will ensure that precipitation does not collect behind the product during the installation process. Once Tyvek® ThermaWrap® R5.0 has been fully and properly installed and the bottom edge sealed, bulk water will not collect behind the product

- If using a DuPont™ Insulated Batten CT or nominal 2" bump-out at the base of the wall, terminate the bottom uninsulated Tyvek® flap. Trim the flap flush with the bottom edge of the DuPont™ Insulated Batten CT. Secure the flap with 3" DuPont™ Tyvek® Tape or a DuPont™ Flashing Systems product. The DuPont™ Flashing Systems product or the 3" DuPont™ Tyvek® Tape must terminate on the DuPont™ Flashing Systems product secured to the wall and foundation.
- If using the termination ledge, remove the uninsulated Tyvek® flap at the bottom and secure to the termination strip with a DuPont™ Tyvek® Flashing Systems product or a DuPont™ Tyvek® Tape.

- If a termination accessory is not used, seal the flap at the bottom of the wall with a DuPont™ Flashing Systems product, DuPont™ Tyvek® Tape, or DuPont™ Residential sealant. The uninsulated flap should cover the bottom edge of insulation before turning down onto the foundation.

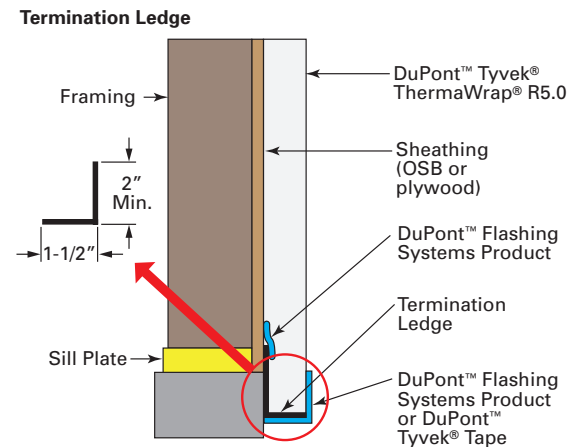
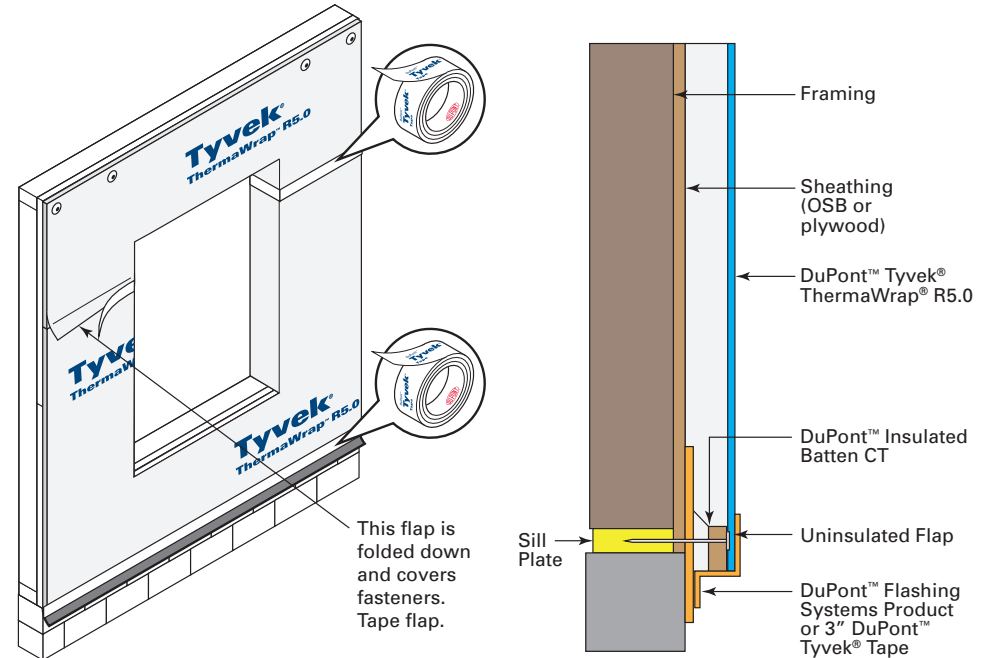

Window Flashing (Flanged Window Installed After WRB)

See page 6 for wood buck installation

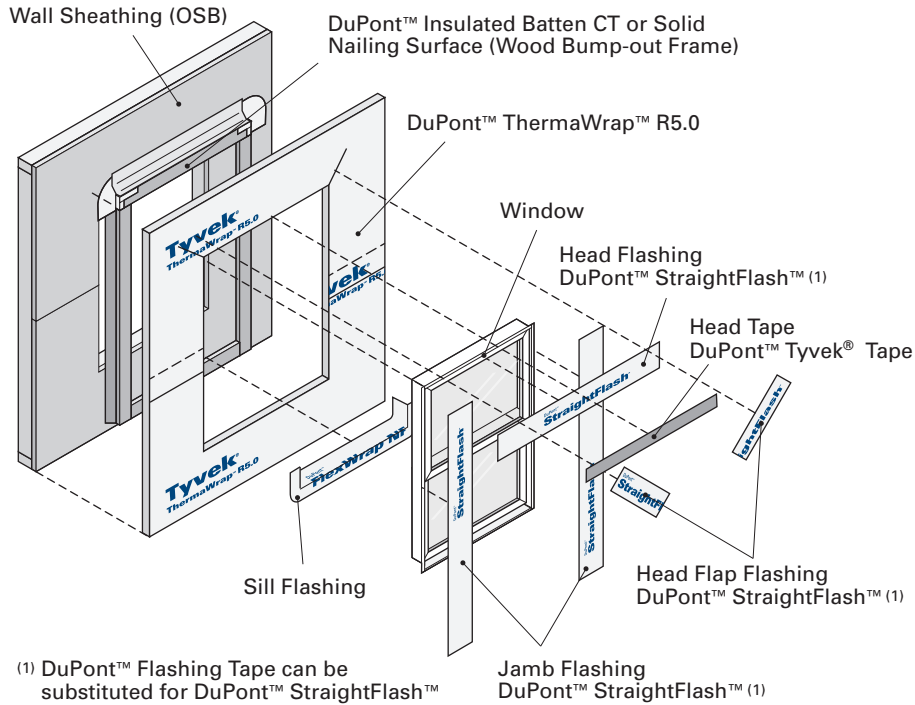

STEP 1 – PREPARING THE WINDOW OPENING

Make an “I-Cut” in the DuPont™ Tyvek® ThermaWrap® R5.0. Begin with a horizontal cut along the bottom and top of the window opening. Both cuts should extend the width of the rough opening. For round top windows, the cut should begin above the mull joint. From the center, cut straight down the sill.

The horizontal cuts must penetrate the Tyvek® top sheet and insulation. It’s not necessary to cut through the insulation when making the vertical cut.

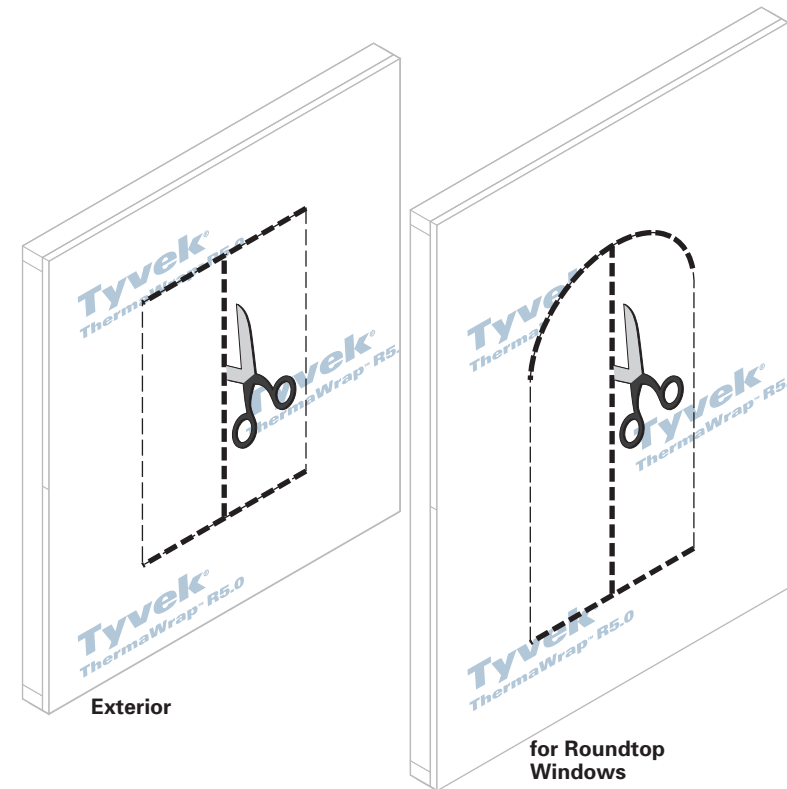

DuPont™ Tyvek® ThermaWrap® R5.0 Installation Guidelines

STEP 2

Cut two 45 degree slits at a minimum of 8" extending from the corner of the window head up and away from the window opening. This will create a flap above the rough opening and expose the bump out frame. Remove the insulation from this flap by separating it from the DuPont™ Tyvek® layer and cutting along the horizontal. **Do not cut or damage the DuPont™ Tyvek®**. Fold back DuPont™ Tyvek® flap and temporarily secure with DuPont™ Tyvek® Seam Tape.

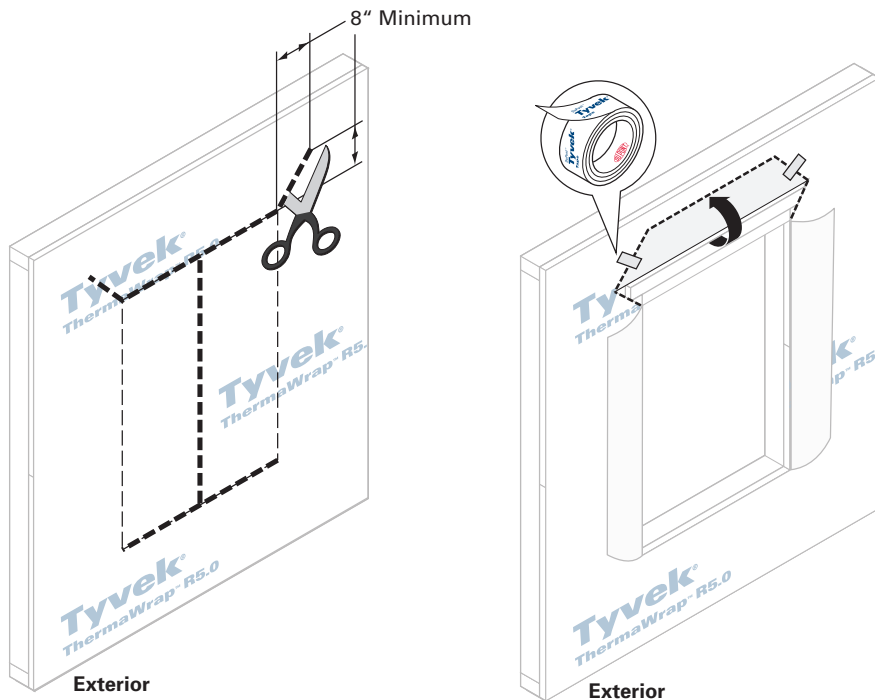

STEP 3

Cut two 45° slits not to exceed 3" extending from the bottom corner up and away from the window opening. Starting at the vertical cut in the middle of the window, separate the Tyvek® layer from the insulation to the outside of the bump-out frame. Starting at the top corners of the bump-out frame, tear or cut straight the insulating fibers along both jambs. This will expose the window opening and the bump-out frame.

At the sill, make 2 vertical cuts starting 1-2" to the outside of the window opening. Both cuts should extend to the bottom of the bump-out frame. Remove the insulation from this flap by separating it from the DuPont™ Tyvek® and cutting along the bottom edge of the bump-out frame. **Do not cut or damage the DuPont™ Tyvek®**. At the bottom corners, carefully push the insulation to the outside of the bump-out frame.

For bump-out frames narrower than 4"

It's not necessary to make the 2 vertical cuts below the sill. Instead, separate the insulation from the Tyvek® layer that sits on top of the bump-out frame along the sill. Tuck the excess insulation along the bottom edge of the bump-out frame.

Ensure there is no insulation on top of the bump-out frame. This can cause the cladding and trim to appear uneven around windows and doors.

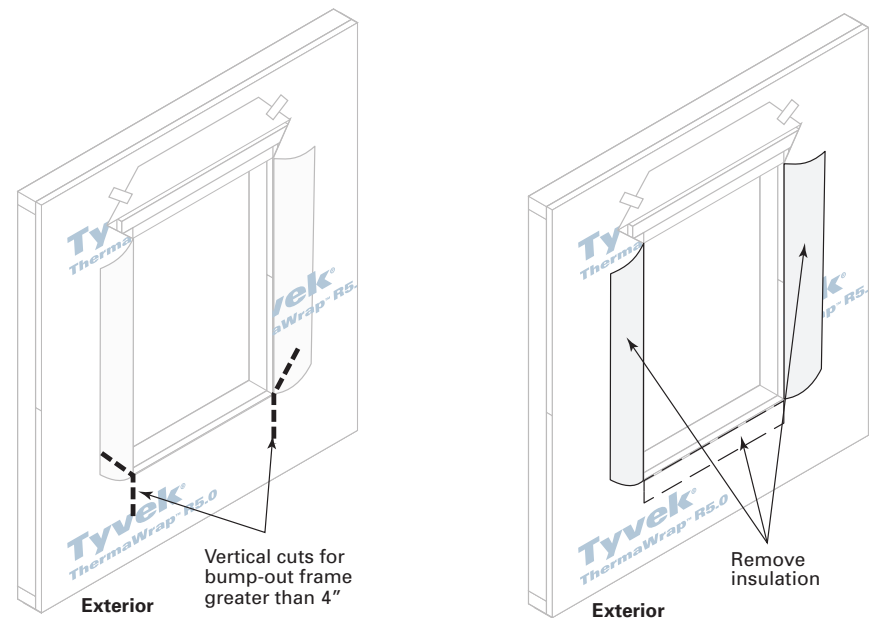

DuPont™ Tyvek® ThermaWrap® R5.0 Installation Guidelines

STEP 4 – INSTALLATION OF FLEXWRAP™ NF

Cut DuPont™ FlexWrap™ NF at least 12" longer than the width of the rough opening sill. The FlexWrap™ NF must extend as far into the opening as the window and still maintain 2-3" on the face of the wall. Remove the first piece of the release paper, cover horizontal sill and adhere into rough opening along sill and up jambs (min. 6" on each side). Remove second release paper. Fan out DuPont™ FlexWrap™ NF at bottom corners onto face of wall. Coverage of DuPont™ FlexWrap™ NF should be 2"-3" onto the face of the wall.

Fold Tyvek® flaps to the inside and secure.

STEP 5

A. Tape along jambs and at the inside of the top and bottom corners of the window opening.

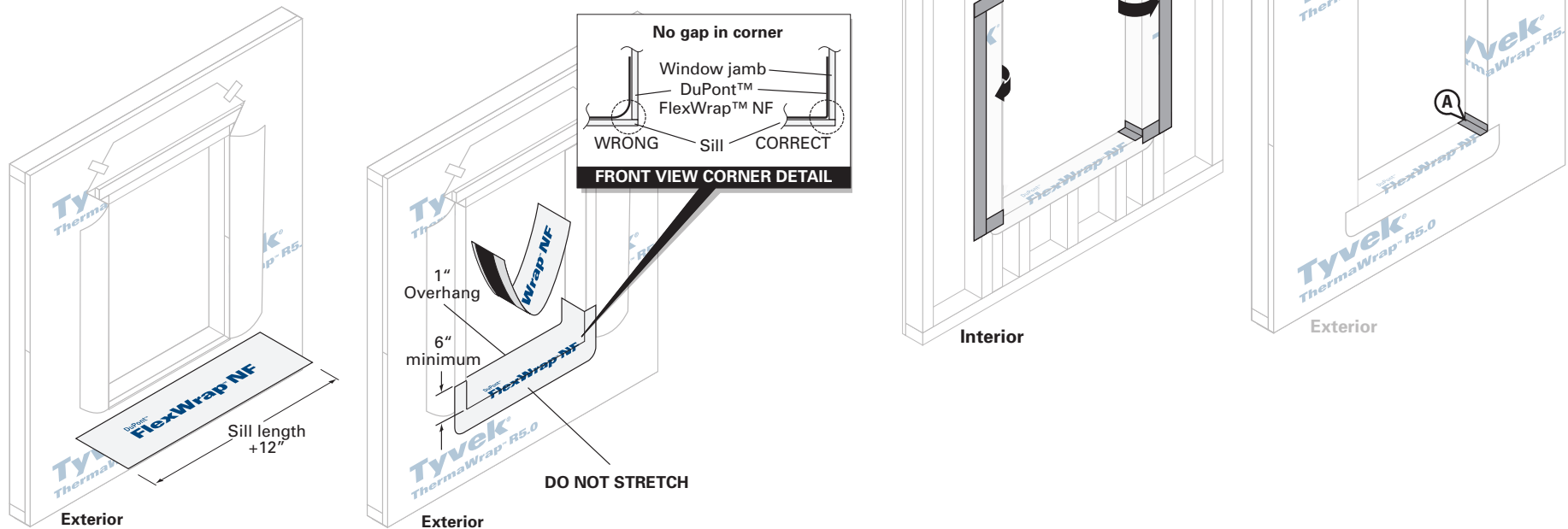

DuPont™ Tyvek® ThermaWrap® R5.0 Installation Guidelines

STEP 6

Apply DuPont™ Residential Sealant, or other sealant, on three sides (jambs and head) as shown. If sealant is applied to the sill, ensure that there are at least (2) 2" gaps in the sealant bead for every 4" of window to allow for drainage.

For Rectangular Windows

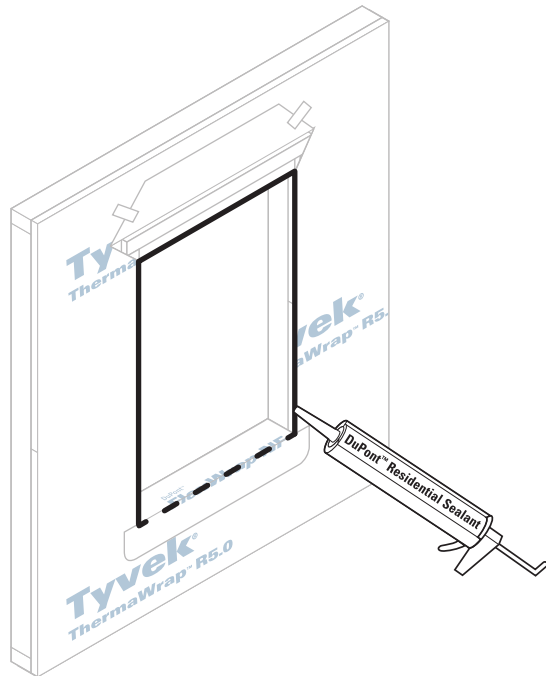

NOTE: DuPont™ Flashing Systems product at jambs must overlap the DuPont™ FlexWrap™ NF at the sill and adhere to the DuPont™ Tyvek® ThermaWrap® R5.0 below the sill.

STEP 7 – WINDOW INSTALLATION AND FLASHING

Install window according to manufacturer's instructions.

Cut two pieces of DuPont™ StraightFlash™ or DuPont™ FlexWrap™ NF or jamb flashing extending 1" above window head flange and below bottom edge of sill flashing. Remove release paper and press tightly along sides of window frame.

Cut a piece of DuPont™ StraightFlash™ or DuPont™ FlexWrap™ for head flashing, which extends beyond outer edges of jamb flashings. Remove release paper and install completely covering mounting flange and adhering to exposed sheathing or framing members.

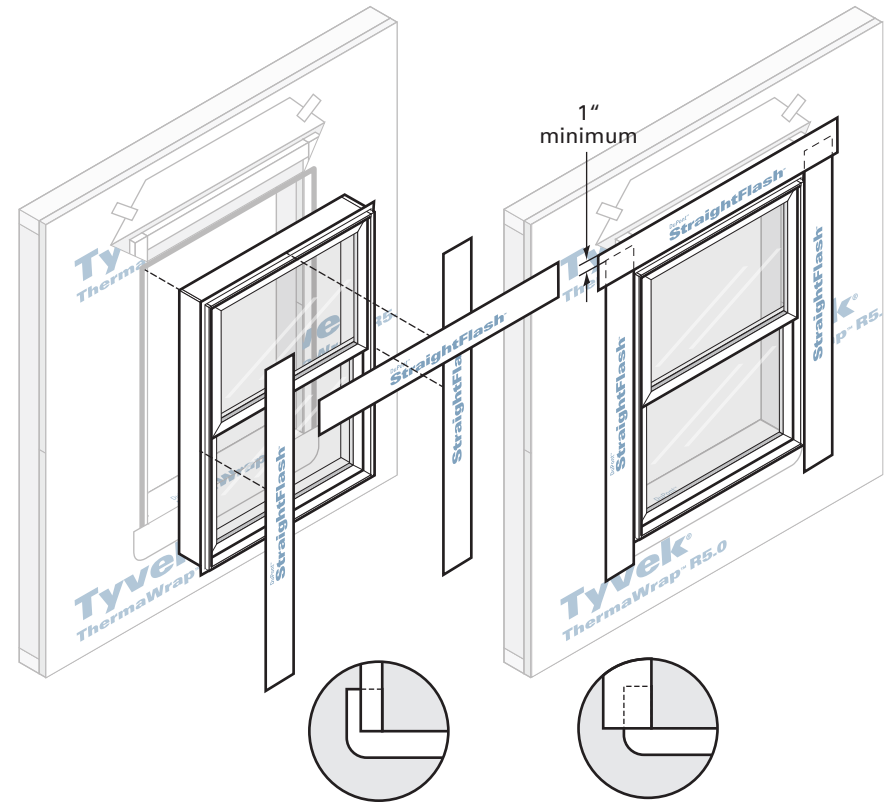

INCORRECT
DuPont™ FlexWrap™ NF
reverse flashed

CORRECT
DuPont™ StraightFlash™
overlaps DuPont™
FlexWrap™ NF

DuPont™ Tyvek® ThermaWrap® R5.0 Installation Guidelines

STEP 8

Flip down DuPont™ Tyvek® ThermaWrap® R5.0 flap so it lies flat across head flashing.

Tape seams as shown. **DO NOT TAPE** at bottom of window. At the head, continuous tape seams as shown with DuPont™ Tyvek® Tape. Apply DuPont™ Flashing Systems products to diagonal seams of DuPont™ Tyvek® ThermaWrap® R5.0.

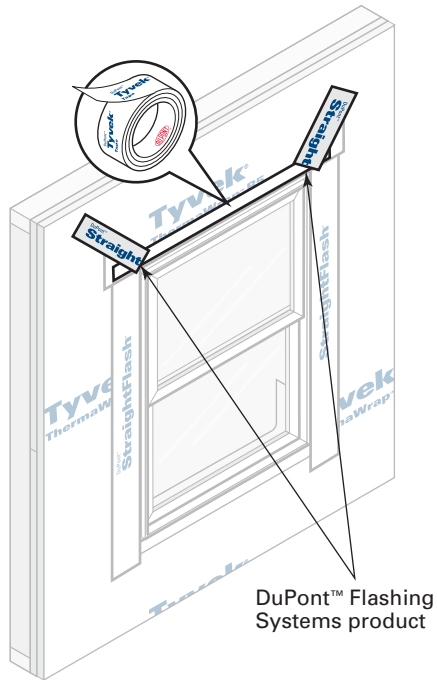

STEP 9

Final Step

Install DuPont™ Residential Sealant, or other sealant, (and backer rod as necessary) around the window opening at the interior. It is also acceptable to use DuPont™ Window and Door Foam or other recommended foam. The seal created by the sealant (and backer rod as necessary) or foam will also serve as a back dam. DuPont™ Residential Sealant should be tooled flat to allow the natural curing process to create a concave shape. Be sure the sealant penetrates the grooves of the DuPont™ FlexWrap™ NF around the sill.

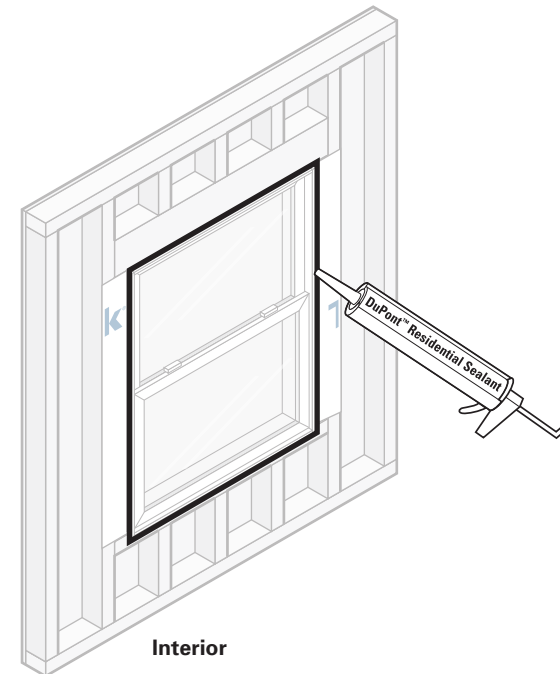

DuPont™ Tyvek® ThermaWrap® R5.0 Installation Guidelines

For Roundtop Windows

STEP 7

NOTE: Follow rectangular window instructions (Steps 1 through 5) for proper installation of sill and jamb flashing prior to head flashing installation.

- A. Cut DuPont™ FlexWrap™ NF head flashing at least 12" LONGER than the arc length (H) of roundtop window.
- B. Remove both release papers and install to conform around top of window, covering entire mounting flange and adhering to exposed sheathing or framing members. Head flashing should overlap jamb flashings at least 6".

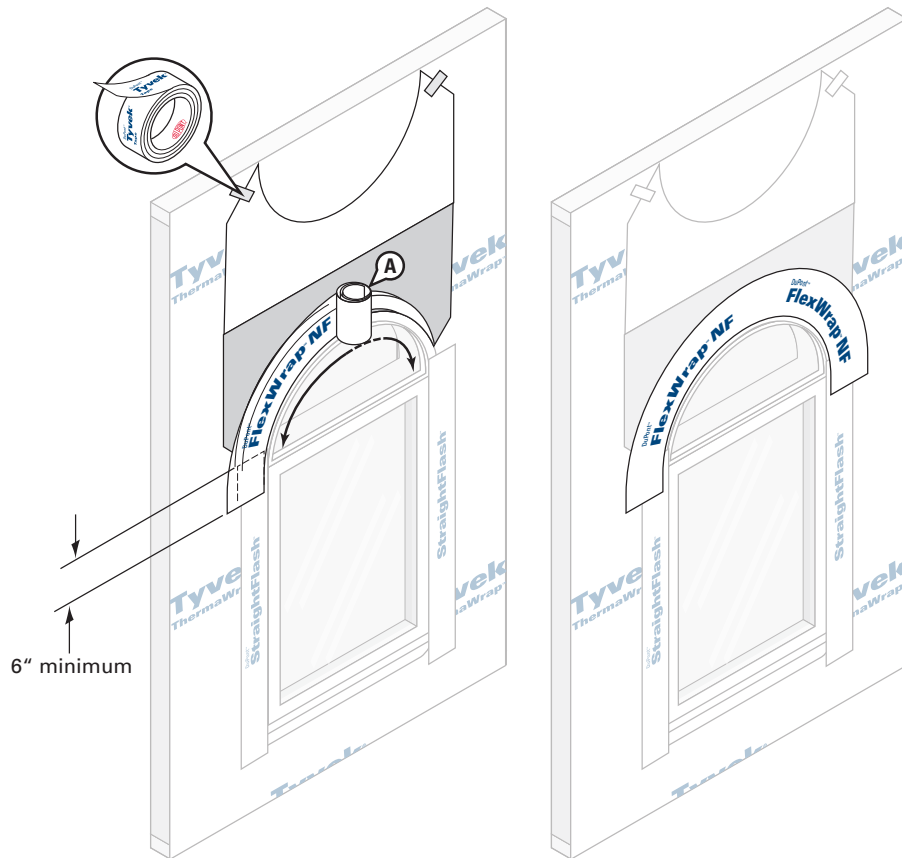

STEP 8

- A. Flip down DuPont™ Tyvek® ThermaWrap® R5.0 flap so it lies flat across head flashing.
- B. Tape seams as shown. **DO NOT TAPE** at bottom of window. At the head, continuous tape seams as shown with DuPont™ Tyvek® Tape.

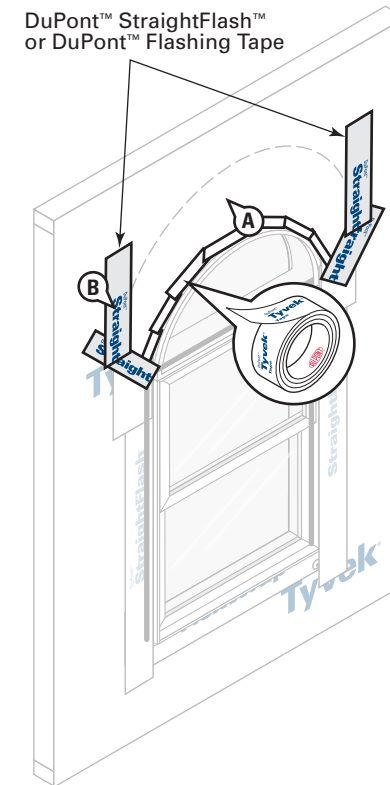

STEP 9

Final Step

Install DuPont™ Residential Sealant, or other sealant, (and backer rod as necessary) around the window opening at the interior. It is also acceptable to use DuPont™ Window and Door Foam or other recommended foam. The seal created by the sealant (and backer rod as necessary) or foam will also serve as a back dam. DuPont™ Residential Sealant should be tooled flat to allow the natural curing process to create a concave shape. Be sure that the sealant penetrates the grooves of the DuPont™ FlexWrap NF™ around the sill.

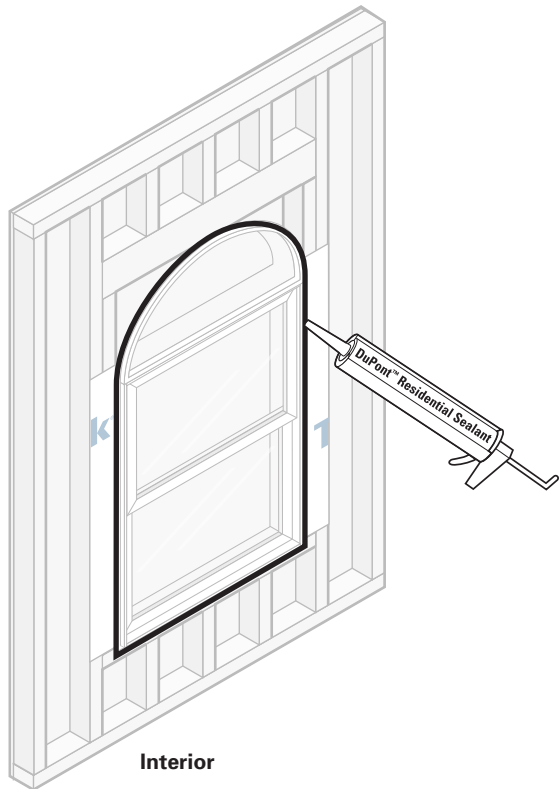

Door Flashing (Brick Mold Door Installed After WRB)

See page 6 for wood buck installation

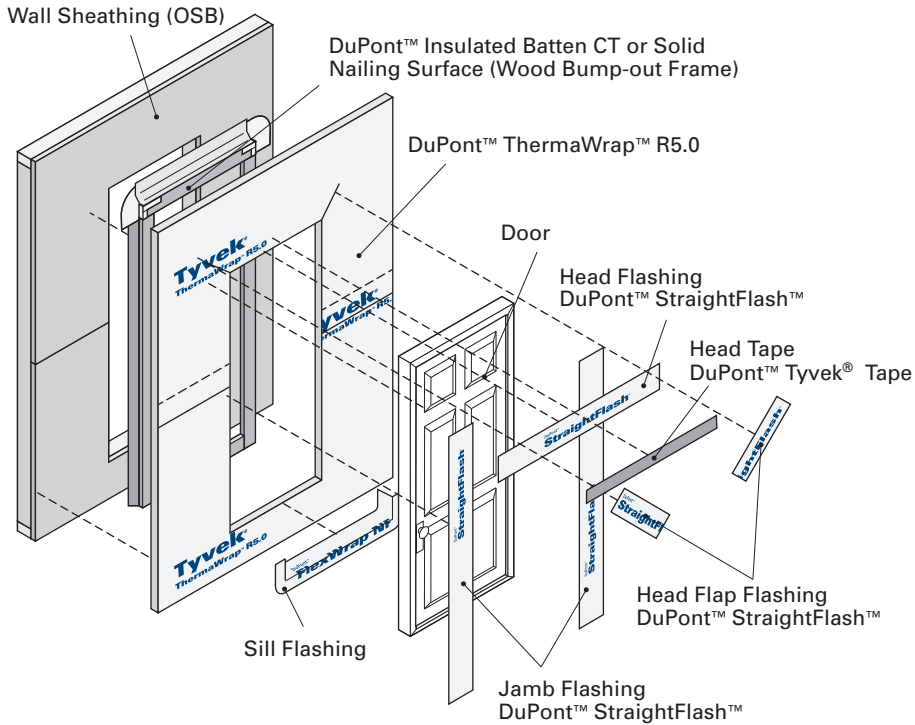

STEP 1 – PREPARING THE DOOR OPENING

Make an “I-Cut” in the DuPont™ Tyvek® ThermaWrap® R5.0. Begin with a horizontal cut along the bottom and top of the door opening. Both cuts should extend the width of the rough opening. From the center, cut straight down the sill.

The horizontal cuts must penetrate the Tyvek® top sheet and insulation. It’s not necessary to cut through the insulation when making the vertical cut.

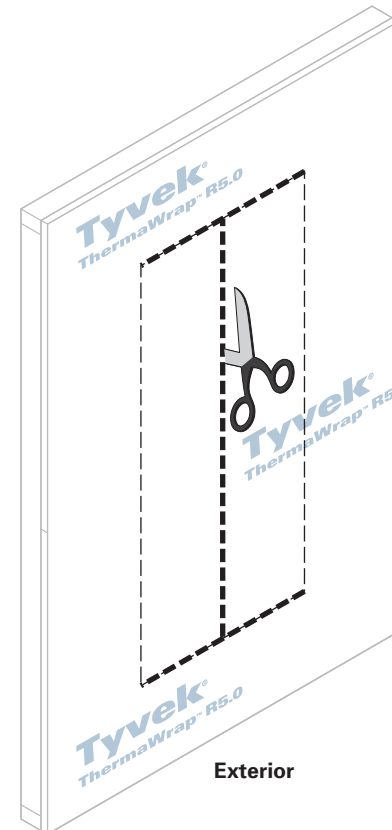

DuPont™ Tyvek® ThermaWrap® R5.0 Installation Guidelines

STEP 2

Cut two 45 degree slits at a minimum of 8" extending from the corner of the door head up and away from the door opening. This will create a flap above the rough opening and expose the bump out frame. Remove the insulation from this flap by separating it from the DuPont™ Tyvek® layer and cutting along the horizontal. **Do not cut or damage the DuPont™ Tyvek®.** Fold back DuPont™ Tyvek® flap and temporarily secure with DuPont™ Tyvek® Seam Tape.

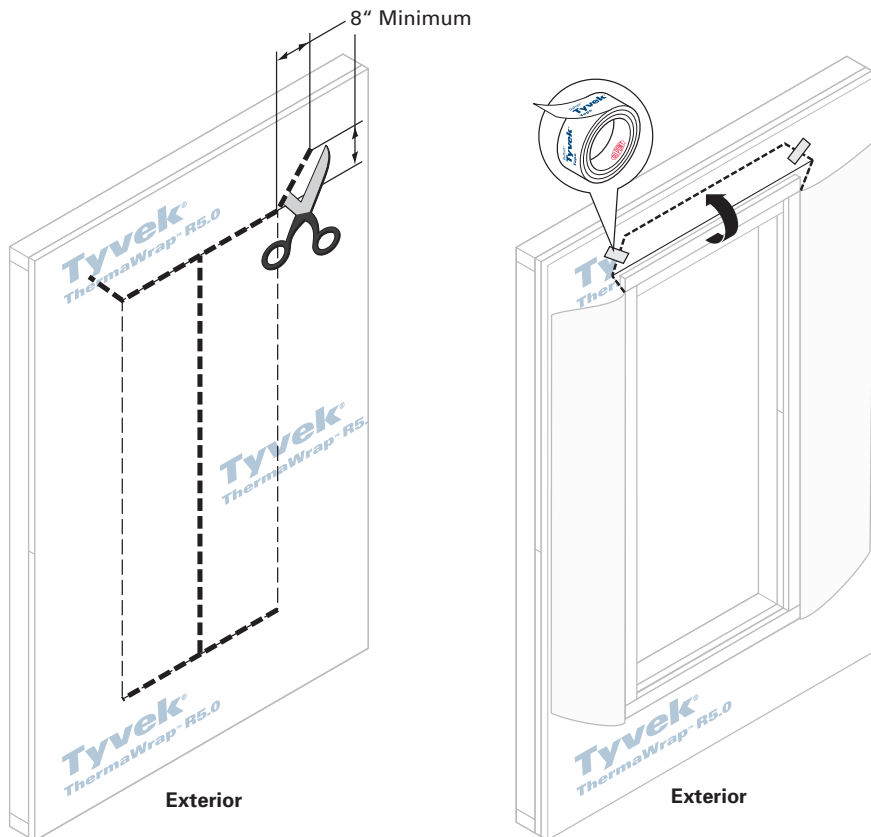

STEP 3

Cut two 45° slits not to exceed 3" extending from the bottom corner up and away from the door opening. Starting at the vertical cut in the middle of the door, separate the Tyvek® layer from the insulation to the outside of the bump-out frame. Starting at the top corners of the bump-out frame, tear or cut straight the insulating fibers along both jambs. This will expose the door opening and the bump-out frame.

At the sill, make 2 vertical cuts starting 1-2" to the outside of the door opening. Both cuts should extend to the bottom of the bump-out frame. Remove the insulation from this flap by separating it from the DuPont™ Tyvek® and cutting along the bottom edge of the bump-out frame. **Do not cut or damage the DuPont™ Tyvek®.** At the bottom corners, carefully push the insulation to the outside of the bump-out frame.

For bump-out frames narrower than 4"

It's not necessary to make the 2 vertical cuts below the sill. Instead, separate the insulation from the Tyvek® layer that sits on top of the bump-out frame along the sill. Tuck the excess insulation along the bottom edge of the bump-out frame.

Ensure there is no insulation on top of the bump-out frame. This can cause the cladding and trim to appear uneven around windows and doors.

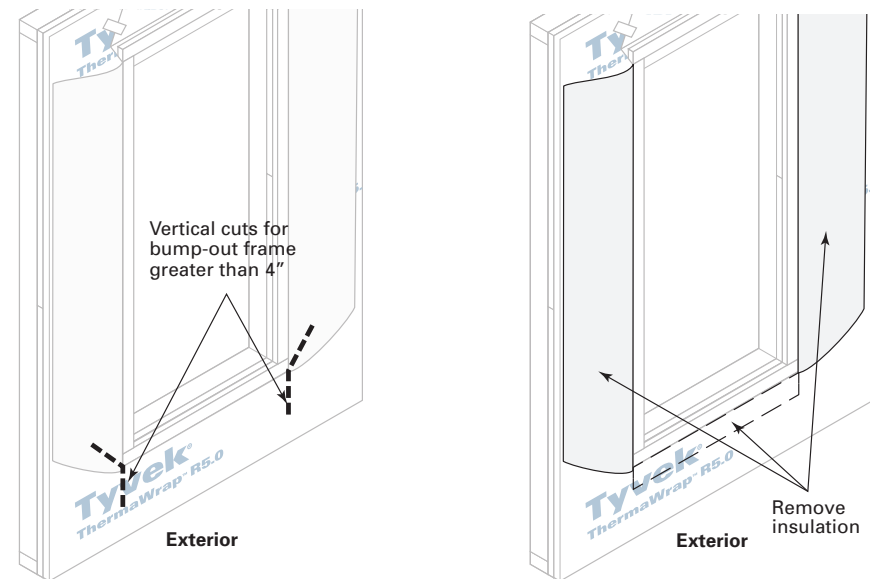

DuPont™ Tyvek® ThermaWrap® R5.0 Installation Guidelines

STEP 4 – INSTALLATION OF FLEXWRAP™ NF

9" DuPont™ FlexWrap™ NF is recommended. Cut DuPont™ FlexWrap™ NF at least 12" longer than the width of the rough opening sill. The FlexWrap™ NF must extend as far into the opening as the window and still maintain 2-3" on the face of the wall. Remove the first piece of the release paper, cover horizontal sill and adhere into rough opening along sill and up jambs (min. 6" on each side). Remove second release paper. Fan out DuPont™ FlexWrap™ NF at bottom corners onto face of wall. Coverage of DuPont™ FlexWrap™ NF should be 2"-3" onto the face of the wall.

Fold Tyvek® flaps to the inside and secure.

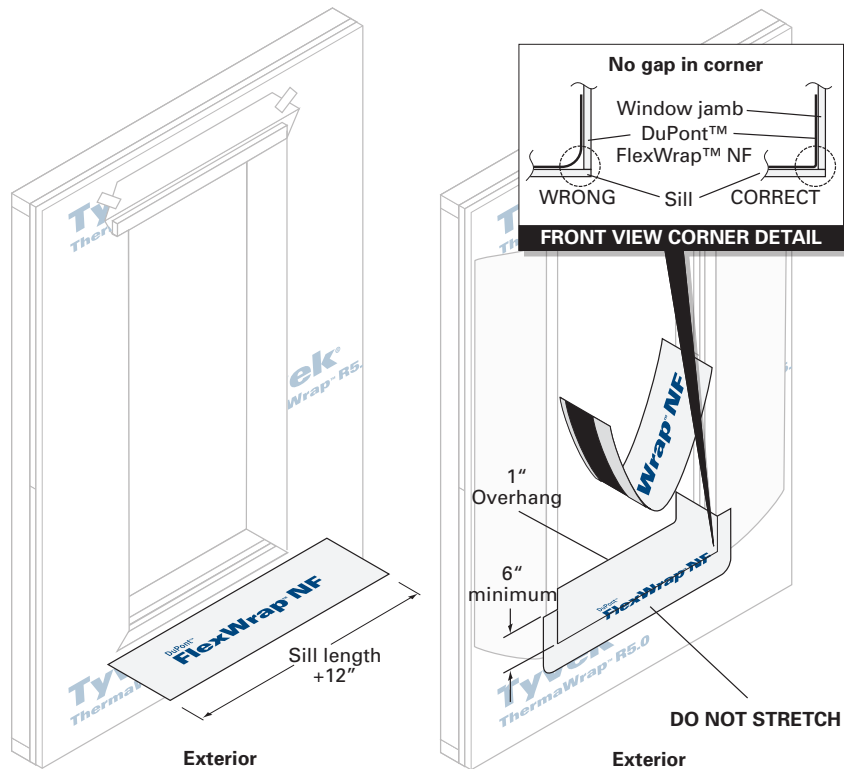

STEP 5

A. Tape along jambs and at the inside of the top and bottom corners of the window opening.

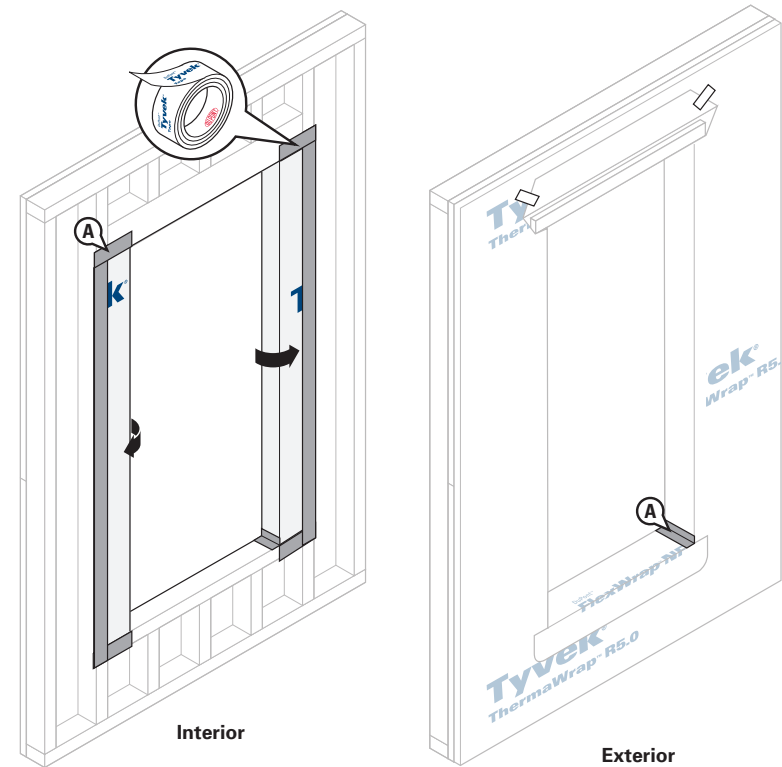

DuPont™ Tyvek® ThermaWrap® R5.0 Installation Guidelines

STEP 5 (OPTIONAL BACK DAM FOR DOORS)

Install the sill flashing as indicated leaving the 1" of DuPont™ FlexWrap™ NF with release paper extending it past the door threshold on the inside. When the 1" of release paper is removed, there should be 3/4" of flashing to form the back dam.

OPTION 2: Some flooring cannot accommodate a back dam. In that case fold the 1" back dam on top of DuPont™ FlexWrap™ NF in the sill. Door will be installed on top of the 1" fold to create a back dam.

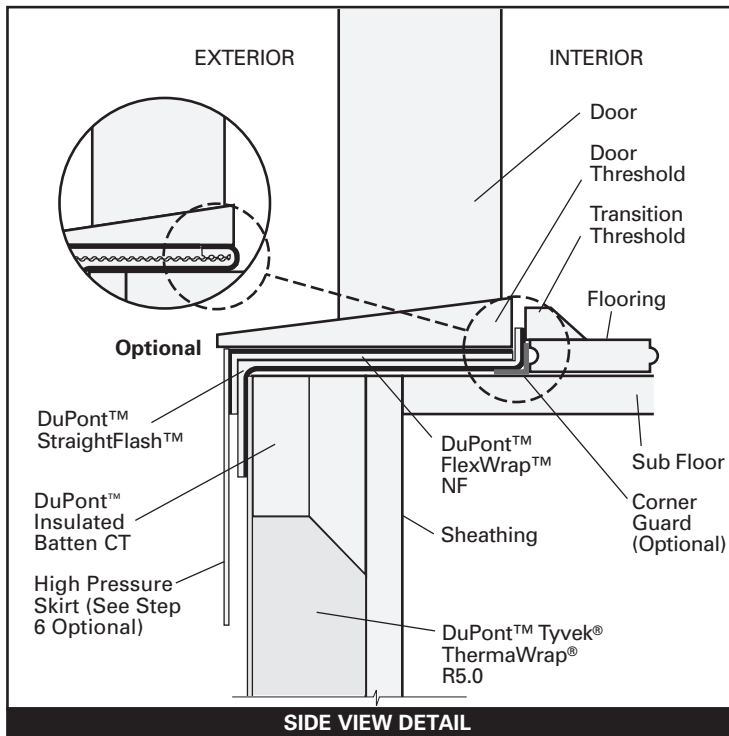

DuPont™ Tyvek® ThermaWrap® R5.0 Installation Guidelines

STEP 6 (OPTIONAL) - HIGH PRESSURE SKIRT (Completing installation of flashing for brick mold door)

For extreme weather conditions, performance requirements exceeding ASTM E1677, or window/door design ratings of DP45 or greater, see General Instructions.

- A. Create the high pressure skirt by cutting a piece of DuPont™ Tyvek® WRB 1" wider than the width of door opening and approximately 10" in height.
- B. Cut a piece of DuPont™ StraightFlash™ VF to the same width of skirt. Remove release paper from one side of DuPont™ StraightFlash™ VF and adhere to DuPont™ Tyvek® WRB. The skirt may be made with either DuPont™ StraightFlash™ VF or DuPont™ StraightFlash™.
- C. Remove the release paper from the other side of DuPont™ StraightFlash™ VF and adhere the butyl adhesive at the sill skirt to the underside of the door threshold behind the jamb flashing.
- D. Secure edges of the optional skirt with two 4" pieces of DuPont™ StraightFlash™.
- E. Tape the bottom of the optional skirt to allow for drainage and to minimize wind damage during construction.
- F. If sealant is applied to the threshold, ensure that there are at least two (2) 2" gaps in the sealant bead to allow for drainage for every 4' of door using DuPont™ Residential Sealant, or other sealant.

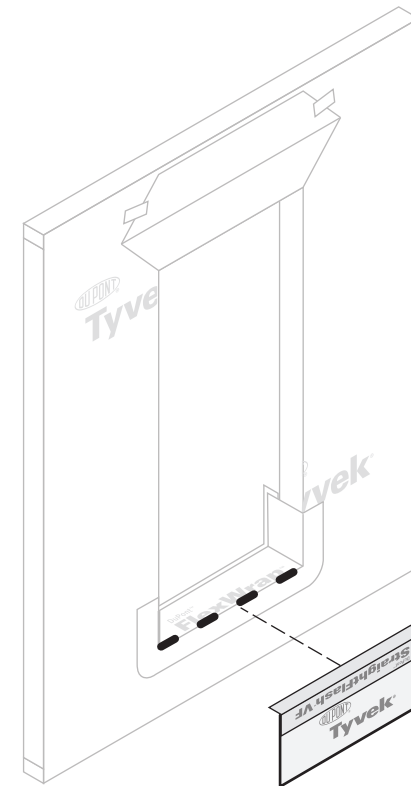
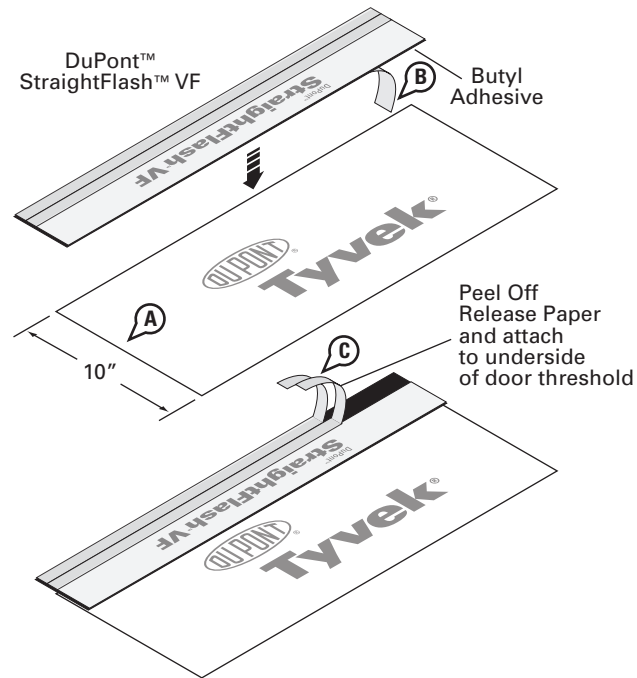

DuPont™ Tyvek® ThermaWrap® R5.0 Installation Guidelines

STEP 7 – STRAIGHTFLASH™ VF INSTALLATION

- A. Prepare head flashing by cutting a piece of DuPont™ StraightFlash™ VF at least twelve (12) inches **LONGER** than the head length.
- B. Break the scored release paper on one edge of the head flashing by folding it back and forth upon itself.
- C. Center the DuPont™ StraightFlash™ VF along the length of the door head and position so that it contacts the door frame and interior side of the brick mold or flange. Remove the outer release paper and adhere the flashing to the door frame. Use the inner release paper to form a tight seal in the corner.
- D. Remove the inner release paper strip and adhere the flashing to the back of the brick mold or flange.
- E. Beginning at the junction of the jamb and head, and away from the corner, cut the DuPont™ StraightFlash™ VF at a 45° angle.
- F. Fold the newly created flashing flap down flat against the brick mold or flange.
- G. Fold remaining head flashing flaps down onto the jamb frame.

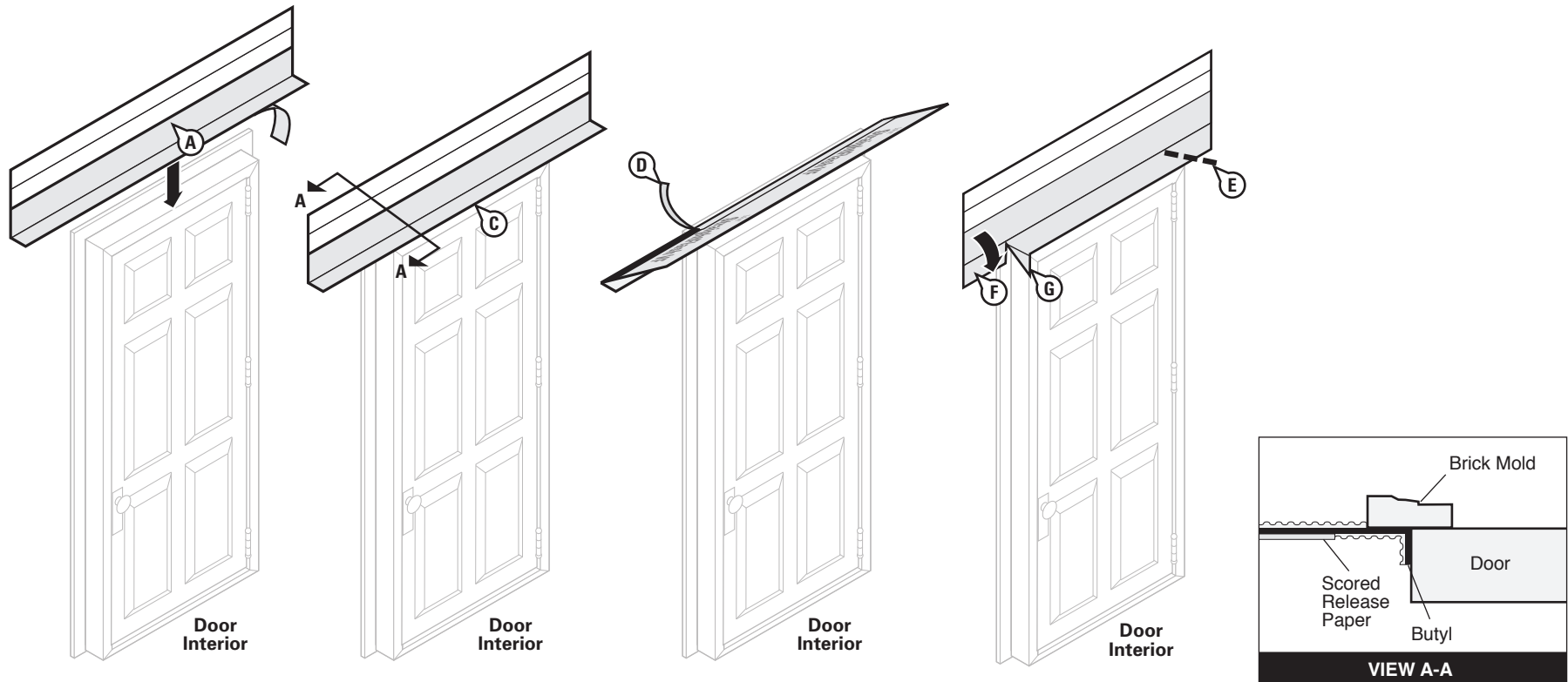

DuPont™ Tyvek® ThermaWrap® R5.0 Installation Guidelines

STEP 8

- Prepare jamb flashing by cutting a piece of DuPont™ StraightFlash™ VF at least six (6) inches **LONGER** than the jamb.
- Break the scored release paper on one side of the jamb flashing by folding it back and forth upon itself.
- Position so that the DuPont™ StraightFlash™ VF contacts the door frame and interior side of the brick mold. Ensure that the jamb flashing is positioned 1-1/2 inch below the top edge of the head flashing. **Jamb flashing adhesive must come in contact with head flashing adhesive by one inch.**
- Remove the outer release paper and adhere the flashing to the door frame. Use the inner release paper to form a tight seal in the corner.
- Remove the inner release paper and adhere the flashing to the back of the brick mold.
- Repeat on for opposite jamb.

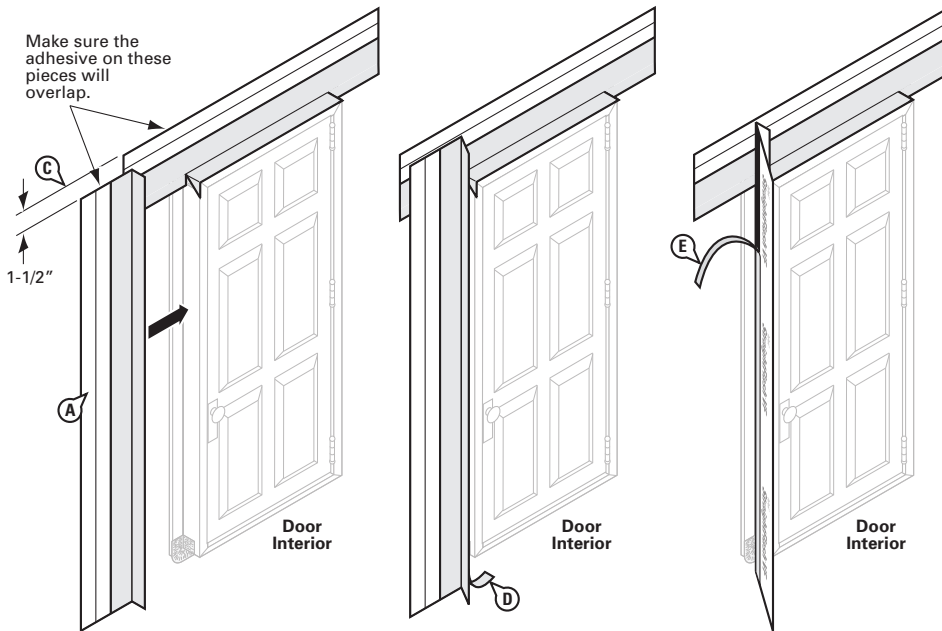

STEP 9

- Beginning at the junction of the jamb and head and beginning at the junction of the jamb and sill, and away from the corner, cut the DuPont™ StraightFlash™ VF along both corners at a 45° angle.
- Fold newly created flaps down flat against the head flashing.
- Fold newly created flaps down onto the head and sill of door frame.

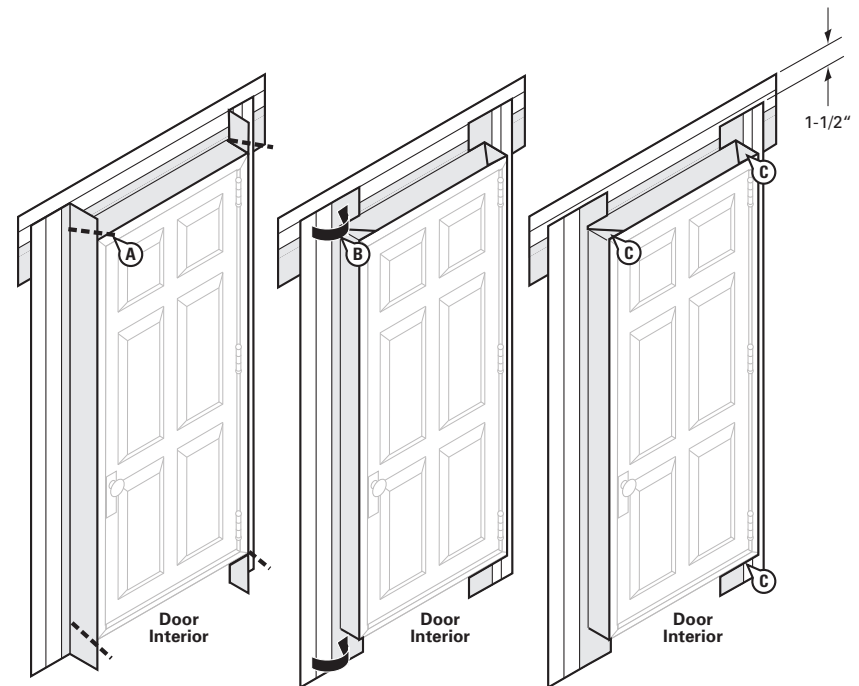

DuPont™ Tyvek® ThermaWrap® R5.0 Installation Guidelines

STEP 10 – DOOR INSTALLATION

- A. Install door according to manufacturer's installation instructions.
- B. Remove the remaining release paper from the DuPont™ StraightFlash™ VF jamb flashing and press firmly to adhere it to the DuPont™ Tyvek® WRB.
- C. Remove the release paper at the head and adhere it to the wall surface.
- D. OPTIONAL: Cover exposed butyl with DuPont™ StraightFlash™ or DuPont™ Flashing Tape.

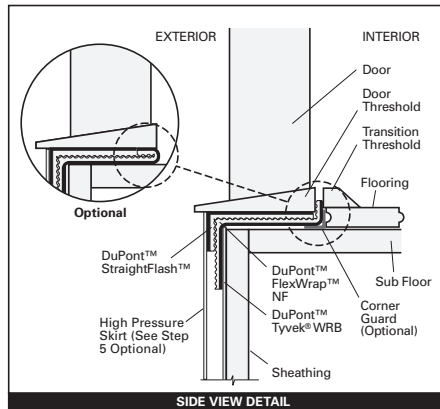
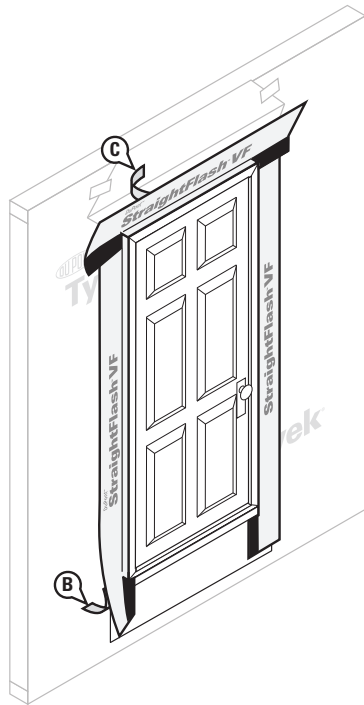

STEP 11 (RECOMMENDED BEST PRACTICE)

- A. OPTIONAL: Cut a piece of metal or vinyl drip cap 1/8" **LONGER** than the width of the door and bend down edges. Place a bead of DuPont™ Residential Sealant, DuPont™ Commercial Sealant or recommended sealant on the rear side. Install the drip cap tight against the door head and cover the top edge with DuPont™ StraightFlash™ or DuPont™ Flashing Tape.
- B. Flip down upper flap of the DuPont™ Tyvek® WRB so it lays flat across head flashing.
- C. Tape seams as shown. **DO NOT TAPE** at bottom of door. At the head, continuous tape seams as shown with DuPont™ Tyvek® Tape; if an air barrier is not required or if additional drainage is desired. Skip-taping at the head is acceptable.
- D. Tape down diagonal seams of DuPont™ Tyvek® WRB.

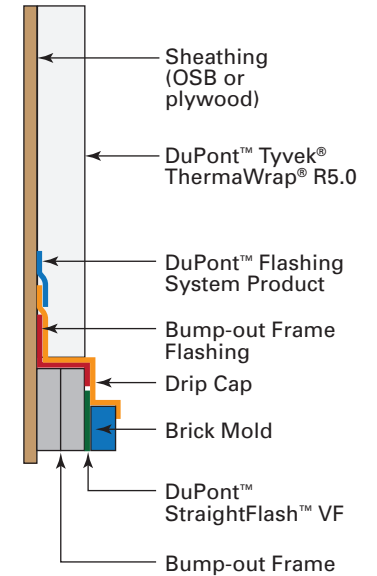
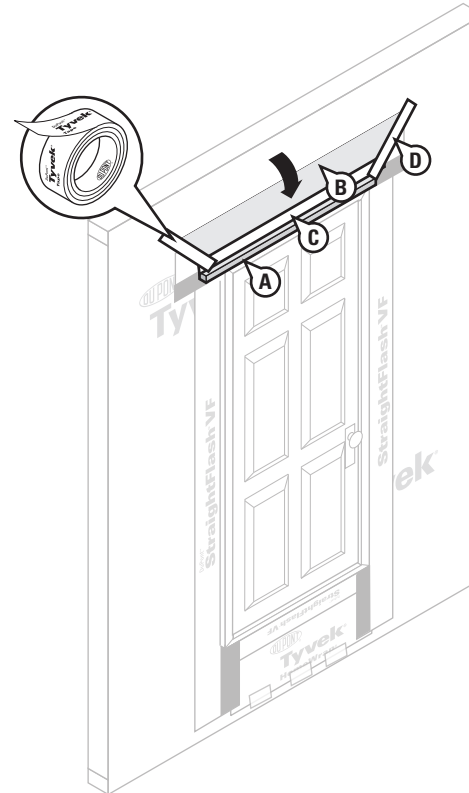

Door Opening

DuPont™ Tyvek® ThermaWrap® R5.0 Installation Guidelines

STEP 12

Final Step

- A. When the interior flooring is ready to install, remove release paper and use Folding Option One or Two to form back dam.
- B. Install DuPont™ Residential Sealant, DuPont™ Commercial Sealant or recommended sealant (and backer rod as necessary) around the door opening at the interior. It is also acceptable to use DuPont™ Window & Door Foam or recommended foam. The seal created by the sealant (and backer rod as necessary) or foam will also serve as a back dam. DuPont™ Residential Sealant or DuPont™ Commercial Sealant should be tooled flat to allow the natural curing process to create a concave shape. Be sure that the sealant penetrates the grooves of the DuPont™ FlexWrap™ NF around the sill.

NOTE: Installations that specify a window/door design rating of DP45 or greater require extra precautions. See General Instructions for performance requirements exceeding this design rating.

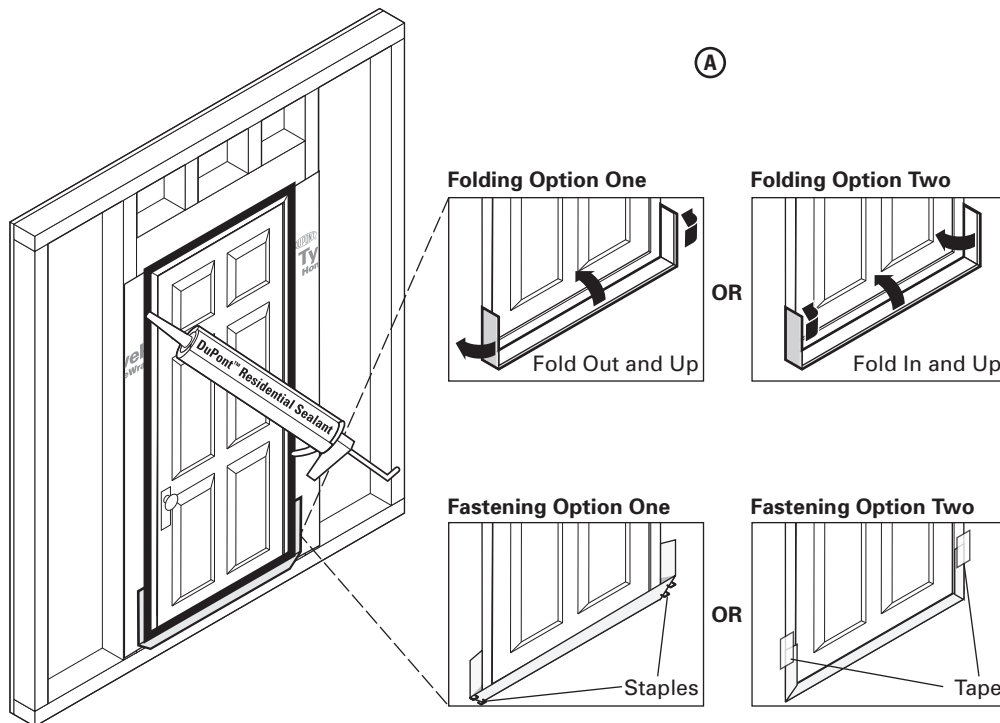

Window Flashing (Flanged Window Installed Before WRB)

See page 6 for wood buck installation

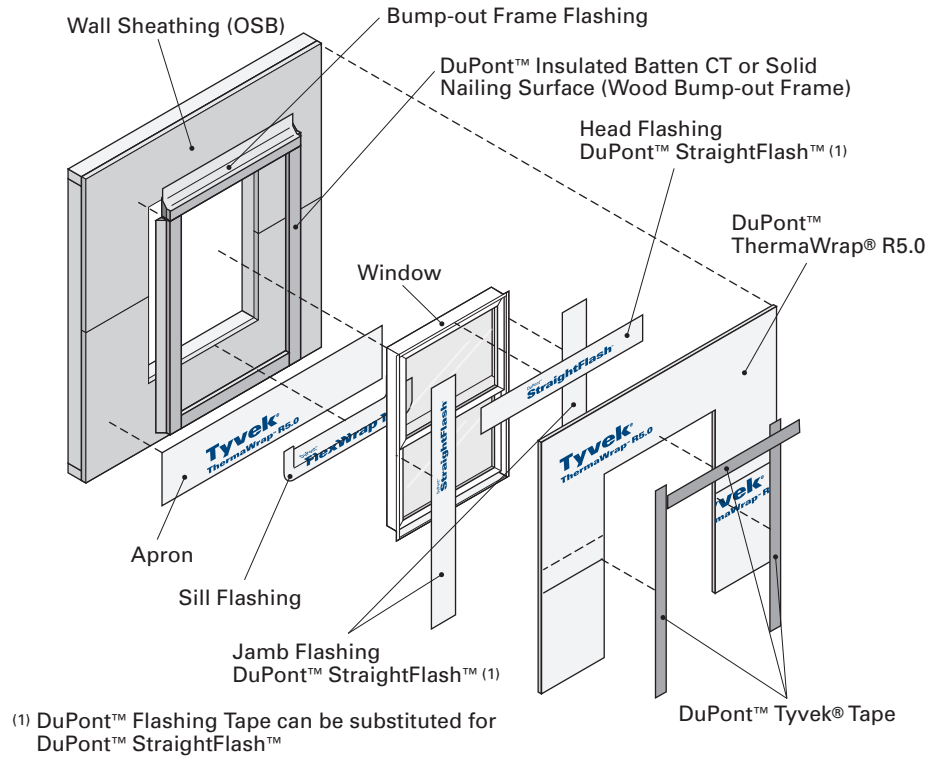

STEP 1 – APRON INSTALLATION

Complete Wall Preparation as shown on pages 6-11. Create apron from DuPont™ Tyvek® ThermaWrap R5.0 by removing the insulation from the back. Any DuPont™ Tyvek® water-resistive barrier (WRB) can also be used. Apron should extend to the outside of the bump-out frame and far enough below the rough opening to overlap the sill plate or WRB below. Apron must overlap the WRB below a min. 6".

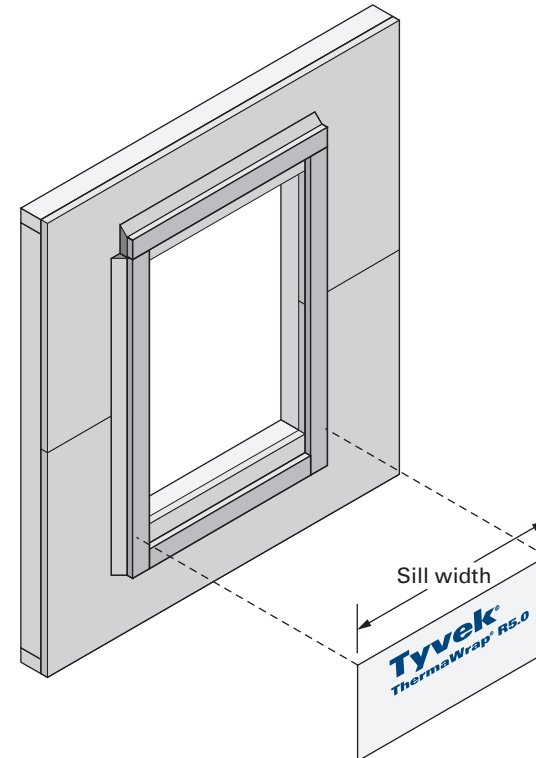

DuPont™ Tyvek® ThermaWrap® R5.0 Installation Guidelines

STEP 2

Use DuPont™ Tyvek® Tape to secure the apron to the bump-out frame at the sill. The bottom of apron should be left free to overlap later with DuPont™ Tyvek® ThermaWrap® R5.0 installation. The top edge of the apron should be flush with the sill.



STEP 3 – INSTALLING FLEXWRAP™ NF

Cut DuPont™ FlexWrap™ NF at least 12" longer than the width of the rough opening sill. The FlexWrap™ NF must extend as far into the opening as the window and still maintain 2-3" on the face of the wall. Remove the first piece of the release paper, cover horizontal sill and adhere into rough opening along sill and up jambs (min. 6" on each side). Remove second release paper. Fan out DuPont™ FlexWrap™ NF at bottom corners onto face of wall. Coverage of DuPont™ FlexWrap™ NF should be 2"-3" onto the face of the wall.

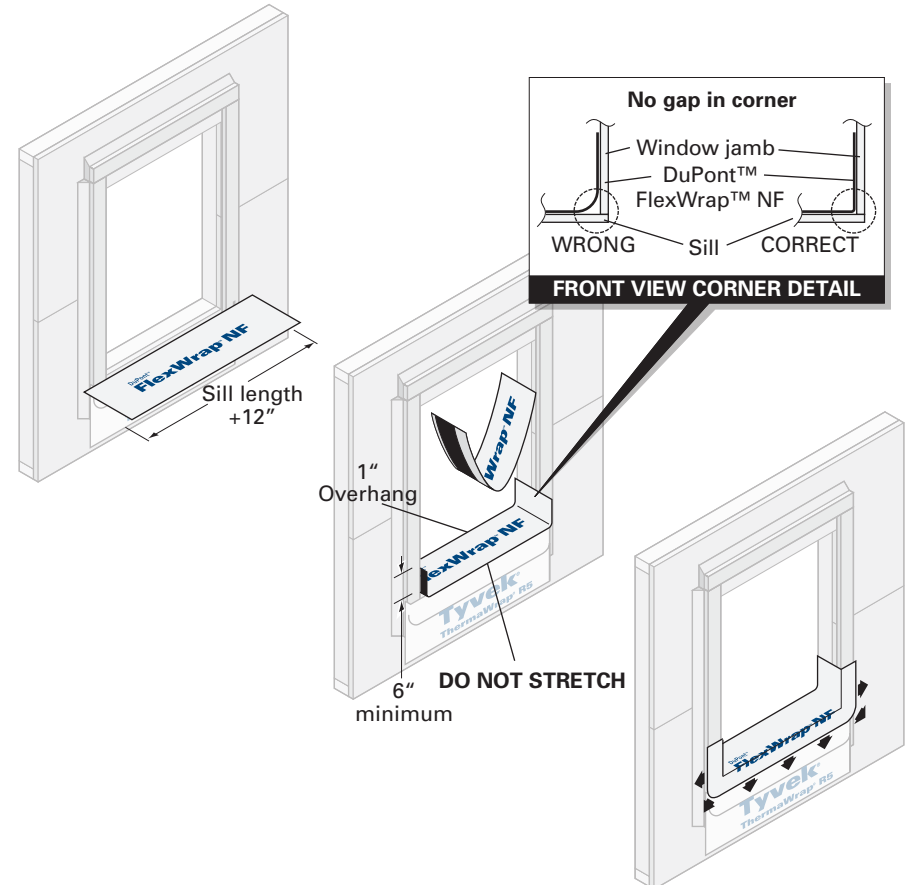

DuPont™ Tyvek® ThermaWrap® R5.0 Installation Guidelines

STEP 4

Apply DuPont™ Residential Sealant, or other sealant, on three sides (jamb and head) as shown. If sealant is applied to the sill, ensure that there are at least (2) 2" gaps in the sealant bead for every 4' of window to allow for drainage.

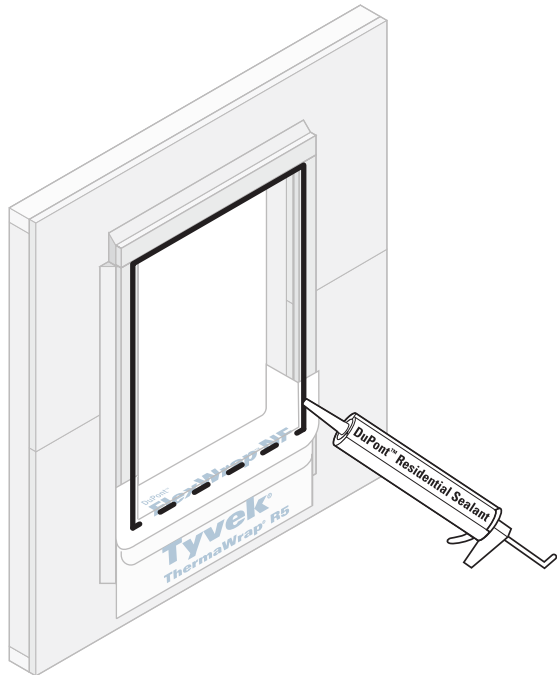

STEP 5 – WINDOW INSTALLATION AND FLASHING

Install window according to manufacturer's instructions

Cut two pieces of a DuPont™ Flashing Systems product for jamb flashing extending 1" above window head flange and extending below bottom edge of sill flashing. Remove release paper and press tightly along the sides of the window frame.

Cut a piece of DuPont™ Flashing Systems product for head flashing to extend beyond outer edges of jamb flashings. Remove release paper and install completely covering mounting flange and adhering to exposed sheathing or framing members.

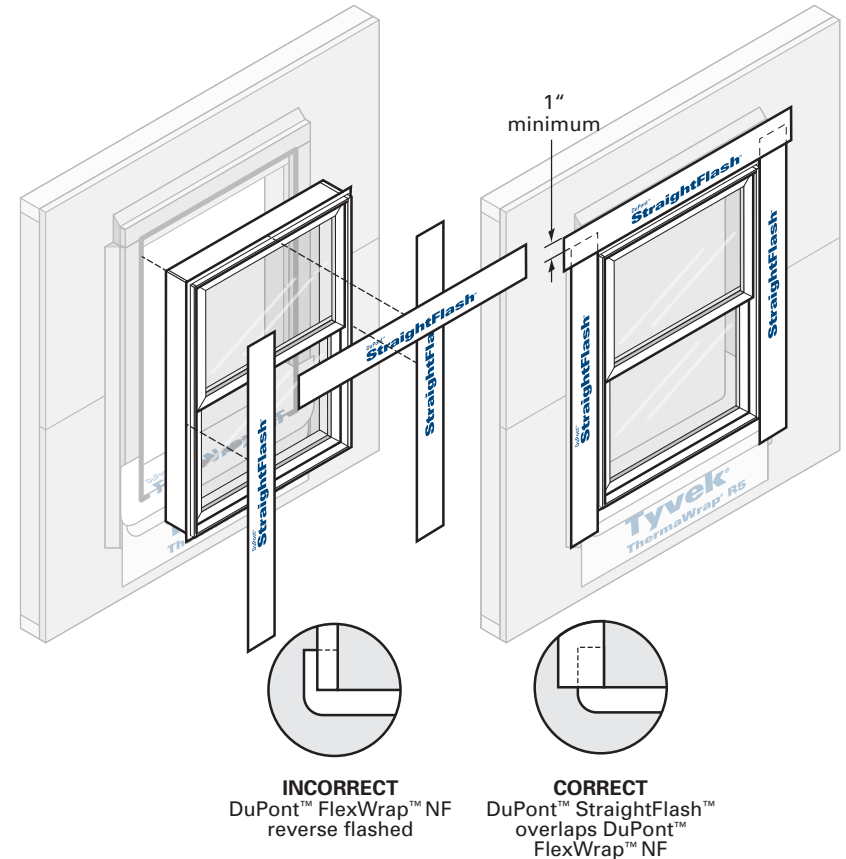

DuPont™ Tyvek® ThermaWrap® R5.0 Installation Guidelines

STEP 6

Install Bump-out Frame Flashing

- A. Install a 4" x 4" piece of DuPont™ FlexWrap™ NF at both upper corners of the bump-out frame. Install 2-3 inches on the wood sheathing and ensure the DuPont™ FlexWrap™ NF extends to the edge or overlaps on to the face of the bump-out frame.
- B. Install DuPont™ Flashing Systems product at the intersection of the wood sheathing and DuPont™ Insulated Batten CT at all windows. Cut a piece the width of the DuPont™ Insulated Batten CT. For round top windows, use DuPont™ FlexWrap™ NF. Install 2-3 inches on the wood sheathing and continue along the top edge of bump-out frame.

OPTION: Use a wider DuPont™ Flashing Systems product to integrate with window flashing

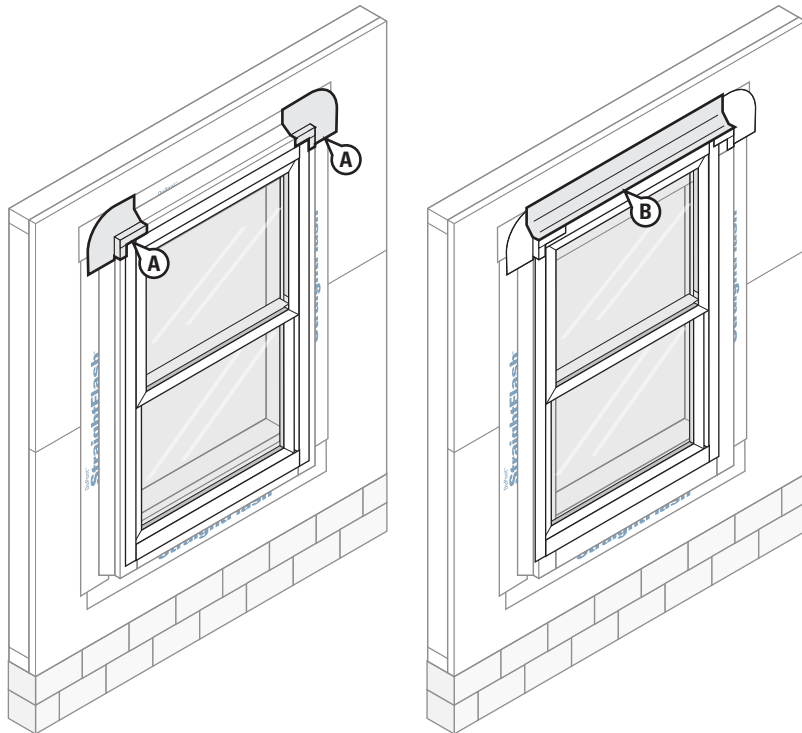

For Roundtop Windows

STEP 7

NOTE: Follow rectangular window instructions (Steps 1 through 5) for proper installation of sill and jamb flashing prior to head flashing installation.

Cut head flashing at least 12" longer than the arc length of round top window.

Remove both release papers and install to conform around top of window, covering entire mounting flange and adhering to exposed sheathing or framing members. Head flashing should overlap jamb flashings at least 6".

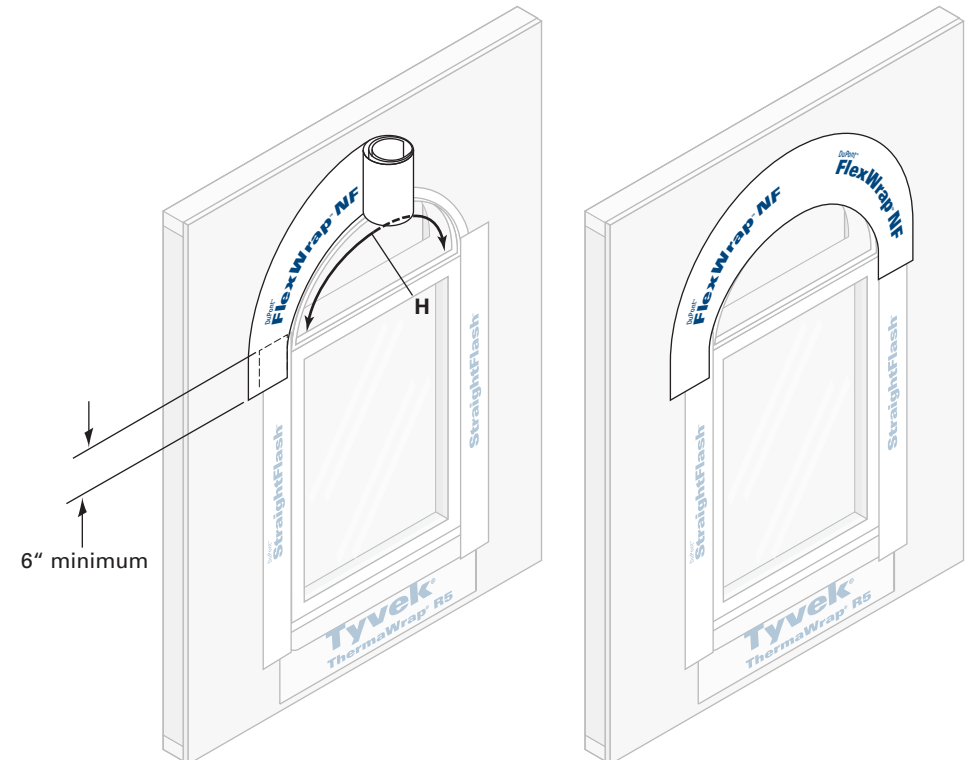

DuPont™ Tyvek® ThermaWrap® R5.0 Installation Guidelines

STEP 8

Install DuPont™ Residential Sealant, or other sealant, (and backer rod as necessary) around the window opening at the interior. It is also acceptable to use DuPont™ Window and Door Foam or other recommended foam. The seal created by the sealant (and backer rod as necessary) or foam will also serve as a back dam. DuPont™ Residential Sealant should be tooled flat to allow the natural curing process to create a concave shape. Be sure the sealant penetrates the grooves of the DuPont™ FlexWrap™ NF around the sill.

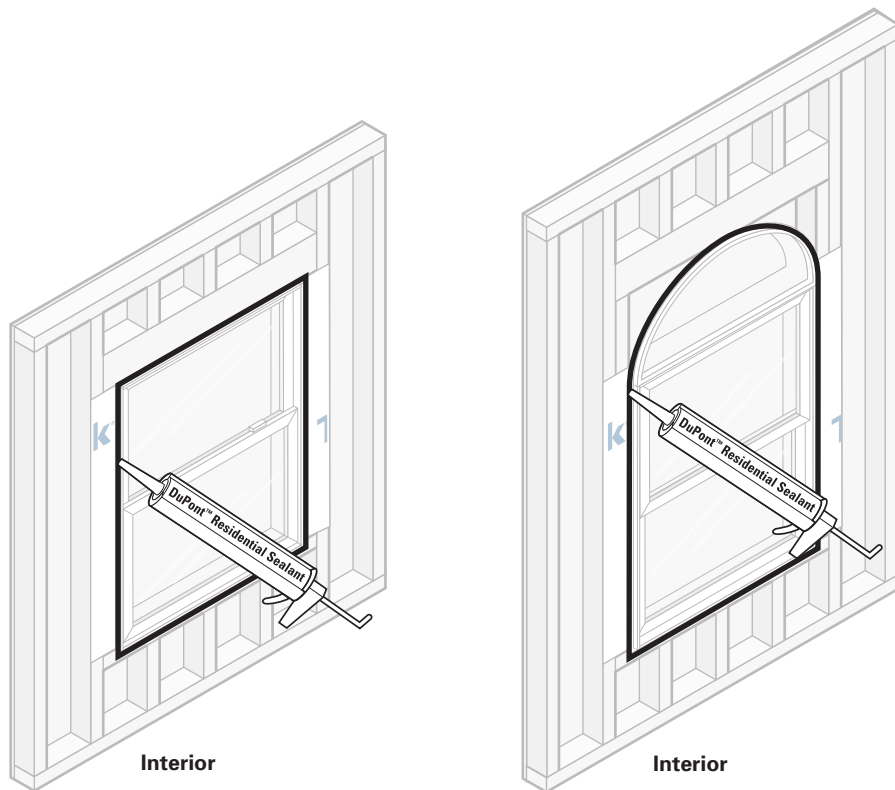

STEP 9 – EXPOSING THE WINDOW

Refer to page 12 for DuPont™ Tyvek® ThermaWrap® R5.0 installation. After installing DuPont™ Tyvek® ThermaWrap® R5.0, use shears to cut as shown to expose window. At the jambs and head, cut around the perimeter of the window frame 1" from the edge.

Do Not cut around the bump-out frame. Make a cut the width of the apron along the bottom edge of the bump-out frame. Make two 45 degree cuts extending from the corner of the window head up and away from the window opening. This will create a flap above the rough opening and expose the bump-out frame. Pull apron to the outside of the DuPont™ Tyvek® ThermaWrap® R5.0.

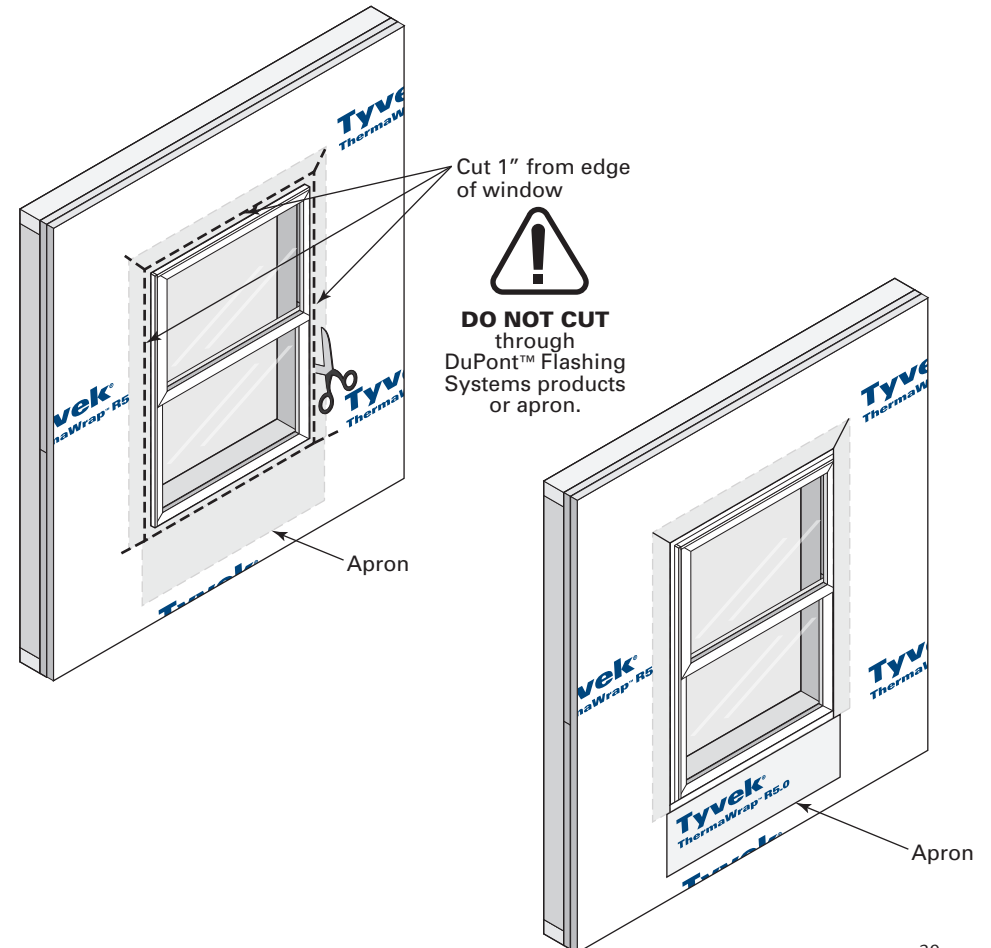

DuPont™ Tyvek® ThermaWrap® R5.0 Installation Guidelines

STEP 11

Remove insulation that overlaps bump-out frame at the head and jambs.

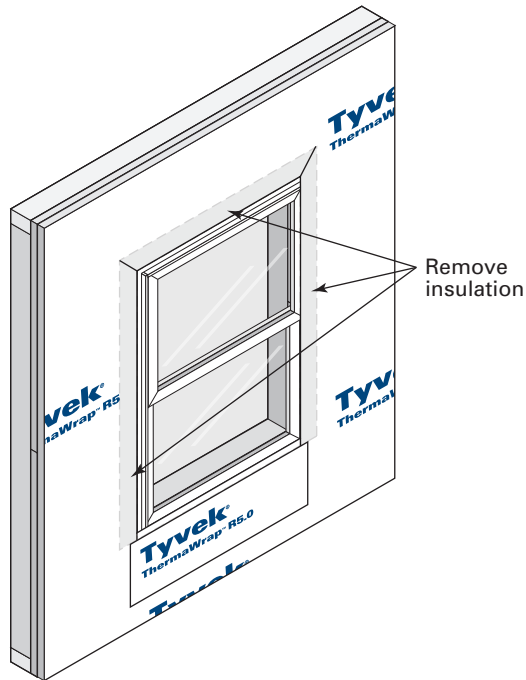

STEP 12 – TERMINATING THE TYVEK® THERMAWRAP® R5.0 AROUND THE WINDOW

Tape as shown using Tyvek® Tape. Use DuPont™ Flashing Systems products at the 45° cuts at the head.

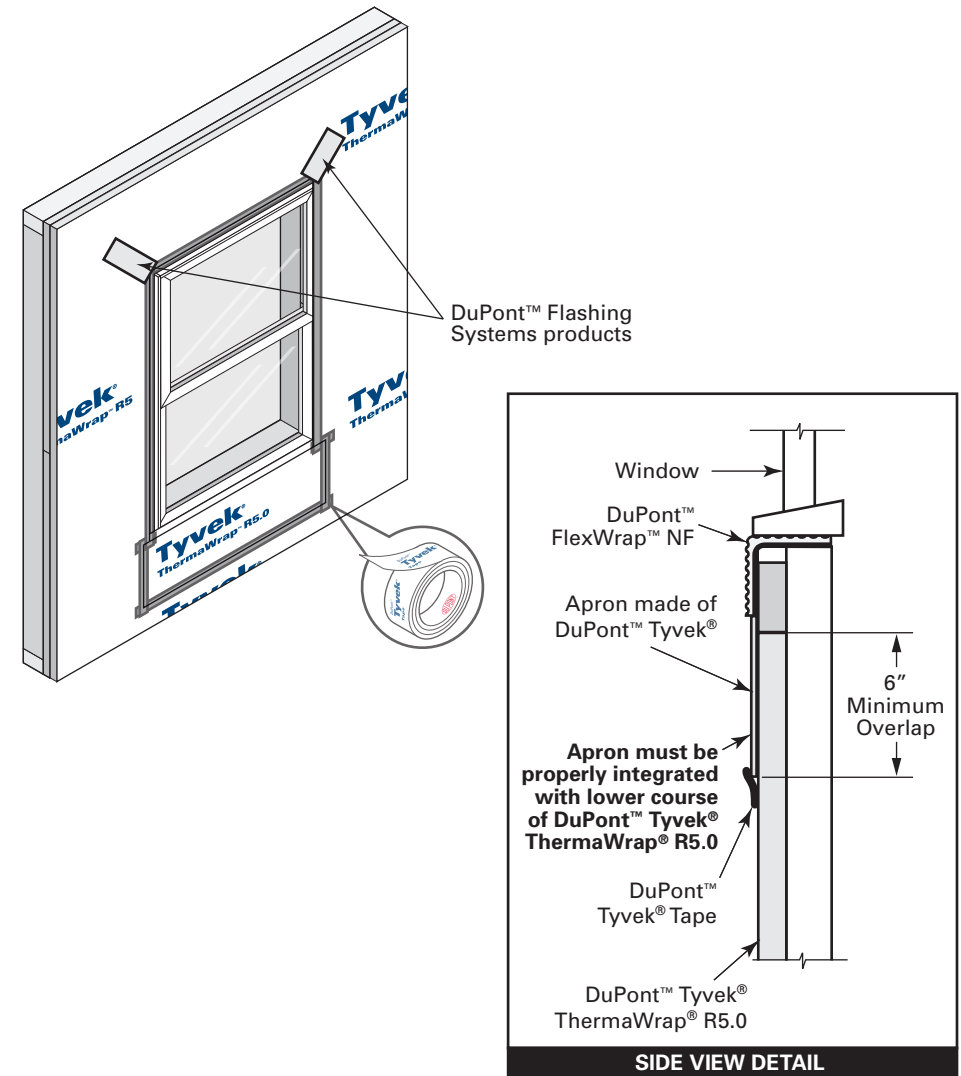

Door Flashing (Brick Mold Door Installed Before WRB)

See page 6 for wood buck installation

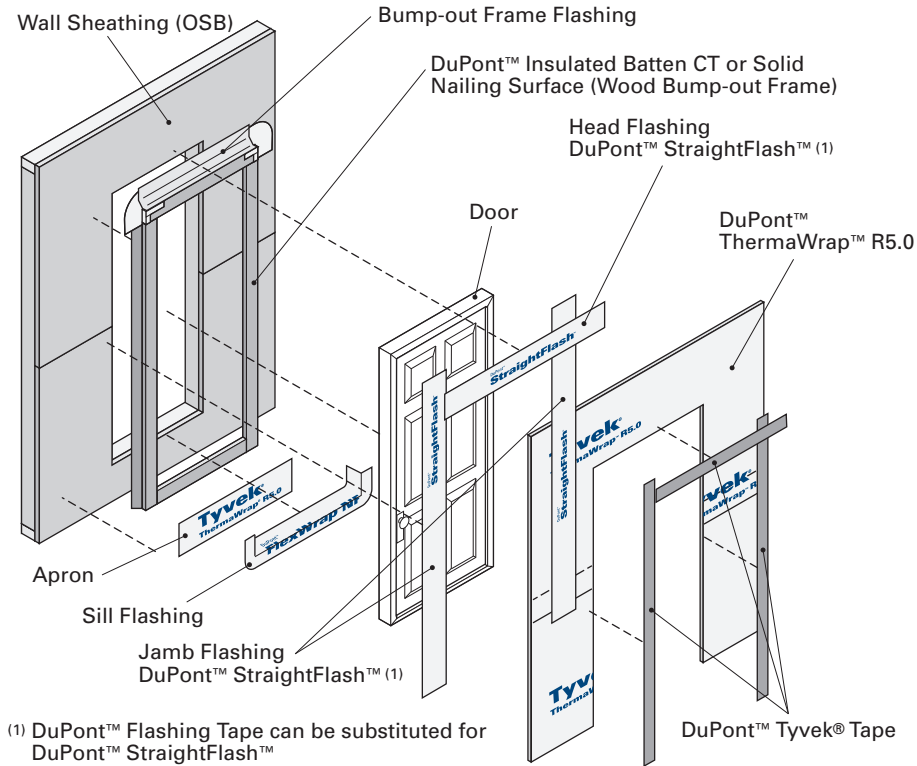

STEP 1 – APRON INSTALLATION

Complete Wall Preparation as shown on pages 6-11. Create apron from DuPont™ Tyvek® ThermaWrap R5.0 by removing the insulation from the back. Any DuPont™ Tyvek® water-resistive barrier (WRB) can also be used. Apron should extend to the outside of the bump-out frame and far enough below the rough opening to overlap the sill plate or WRB below. Apron must overlap the WRB below a min. 6".

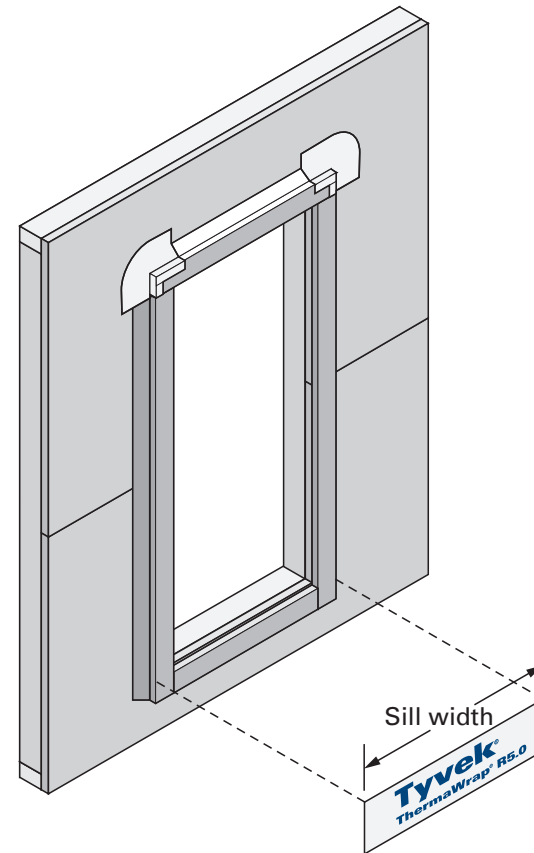

STEP 2 – FLEXWRAP™ NF INSTALLATION

Preparation of sill flashing:

- A. Cut piece of DuPont™ FlexWrap™ NF at least 12" **LONGER** than the width of the sill (S).
- B. DuPont™ FlexWrap™ NF has perforated release paper to help with the formation of the back dam. To ensure that the perforation tears cleanly, fold the perforation 180° and crease the flashing.
- C. Remove the two widest pieces of release paper leaving the narrowest release paper on the flashing. When the finished floor is applied, the release paper can be removed and the back dam can be completed.

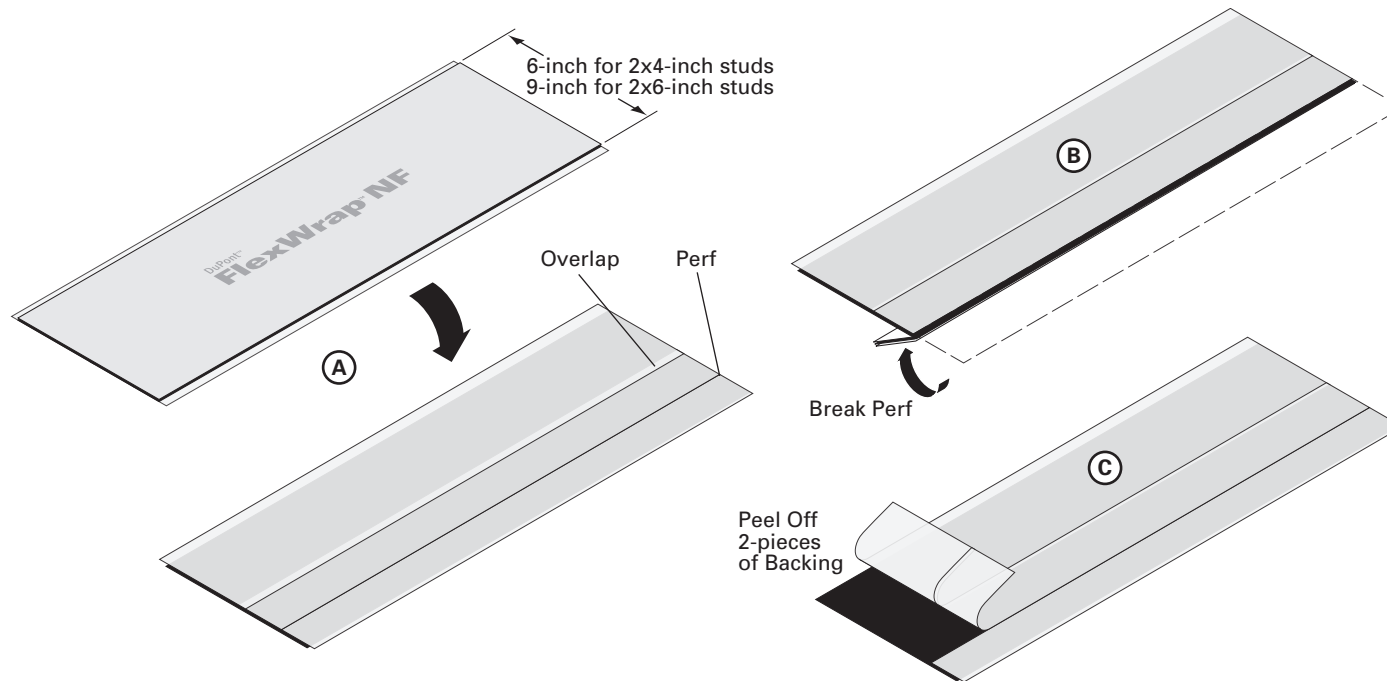

DuPont™ Tyvek® ThermaWrap® R5.0 Installation Guidelines

STEP 3 (OPTIONAL BACK DAM)

Install the sill flashing as indicated leaving the 1" of DuPont™ FlexWrap™ NF with release paper extending it past the door threshold on the inside. When the 1" of release paper is removed, there should be 3/4" of flashing to form the back dam.

OPTION 2: Some flooring cannot accommodate a back dam. In that case fold the 1" back dam on top of DuPont™ FlexWrap™ NF in the sill. Door will be installed on top of the 1" fold to create a back dam.

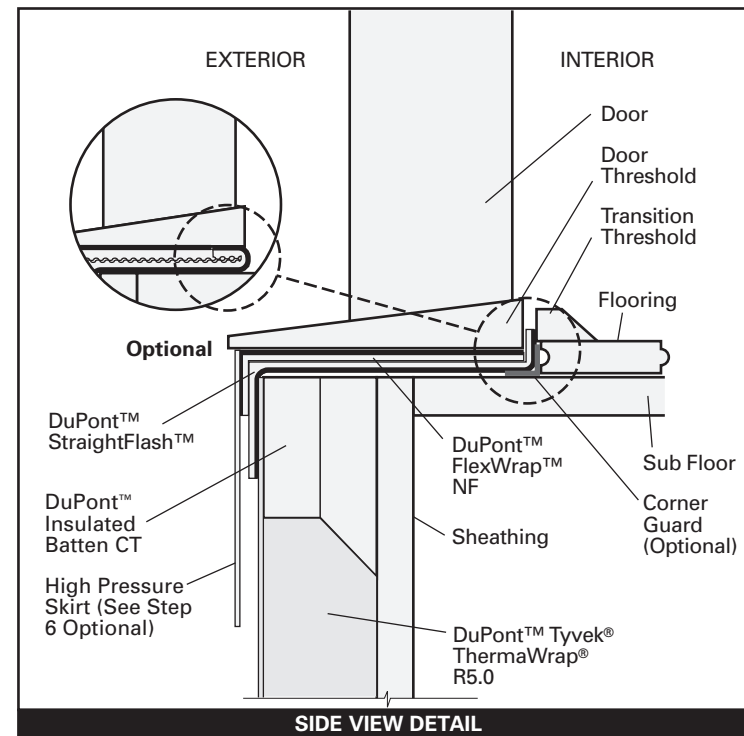
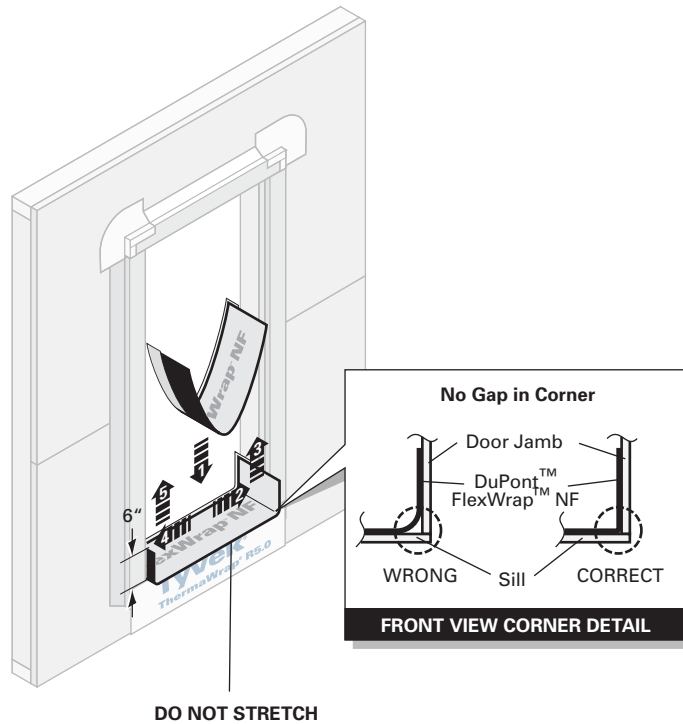

DuPont™ Tyvek® ThermaWrap® R5.0 Installation Guidelines

STEP 4

- A. Fan out DuPont™ FlexWrap™ NF at bottom corners onto the face of the wall.
Coverage of DuPont™ FlexWrap™ NF should be 2" to 3" onto the face of the wall.

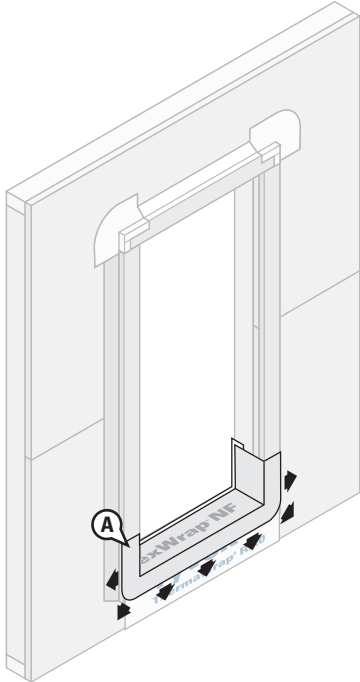

DuPont™ Tyvek® ThermaWrap® R5.0 Installation Guidelines

STEP 5 – STRAIGHTFLASH™ VF INSTALLATION

- A. Prepare head flashing by cutting a piece of DuPont™ StraightFlash™ VF at least twelve (12) inches **LONGER** than the head length.
- B. Break the scored release paper on one edge of the head flashing by folding it back and forth upon itself.
- C. Center the DuPont™ StraightFlash™ VF along the length of the door head and position so that it contacts the door frame and interior side of the brick mold or flange. Remove the outer release paper and adhere the flashing to the door frame. Use the inner release paper to form a tight seal in the corner.
- D. Remove the inner release paper strip and adhere the flashing to the back of the brick mold or flange.
- E. Beginning at the junction of the jamb and head, and away from the corner, cut the DuPont™ StraightFlash™ VF at a 45° angle.
- F. Fold the newly created flashing flap down flat against the brick mold or flange.
- G. Fold remaining head flashing flaps down onto the jamb frame.

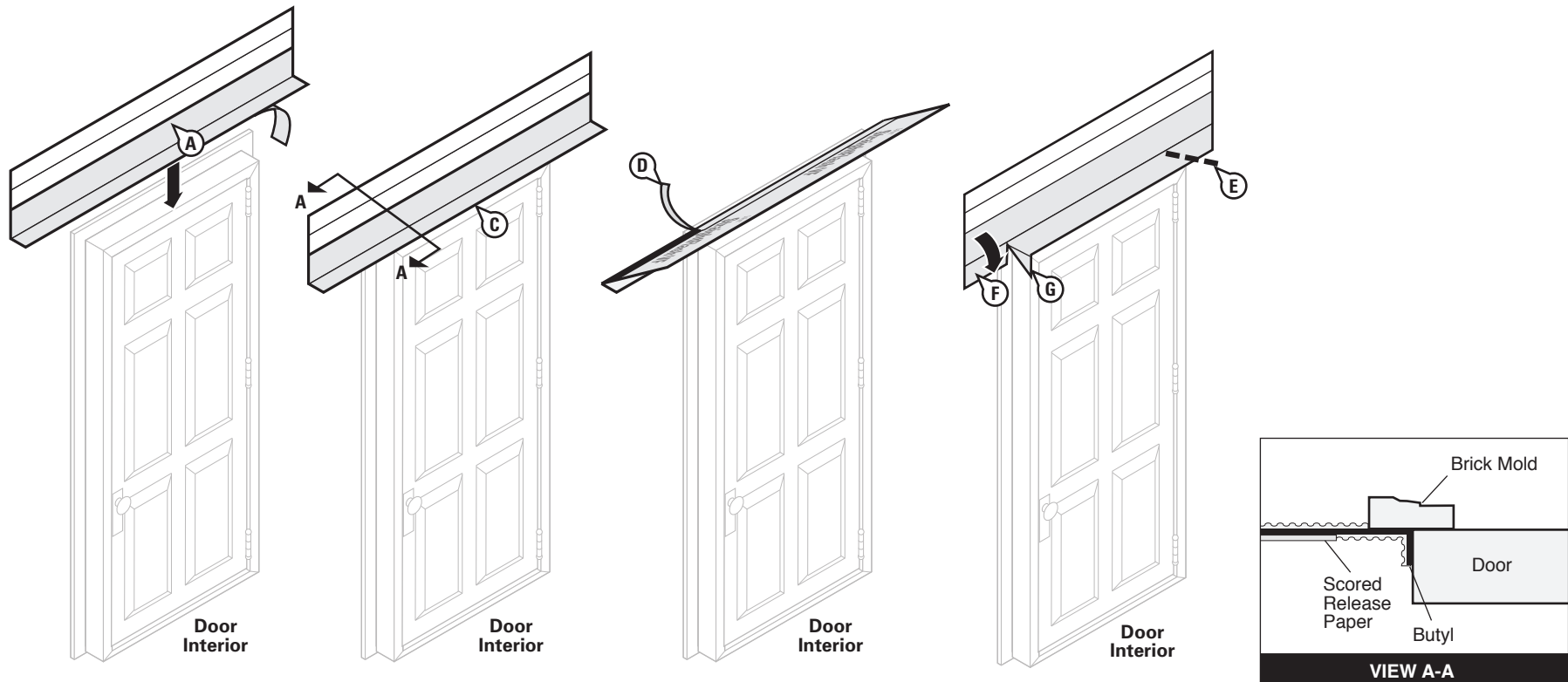

DuPont™ Tyvek® ThermaWrap® R5.0 Installation Guidelines

STEP 6

- Prepare jamb flashing by cutting a piece of DuPont™ StraightFlash™ VF at least six (6) inches **LONGER** than the jamb.
- Break the scored release paper on one side of the jamb flashing by folding it back and forth upon itself.
- Position so that the DuPont™ StraightFlash™ VF contacts the door frame and interior side of the brick mold. Ensure that the jamb flashing is positioned 1-1/2 inch below the top edge of the head flashing. **Jamb flashing adhesive must come in contact with head flashing adhesive by one inch.**
- Remove the outer release paper and adhere the flashing to the door frame. Use the inner release paper to form a tight seal in the corner.
- Remove the inner release paper and adhere the flashing to the back of the brick mold.
- Repeat on for opposite jamb.

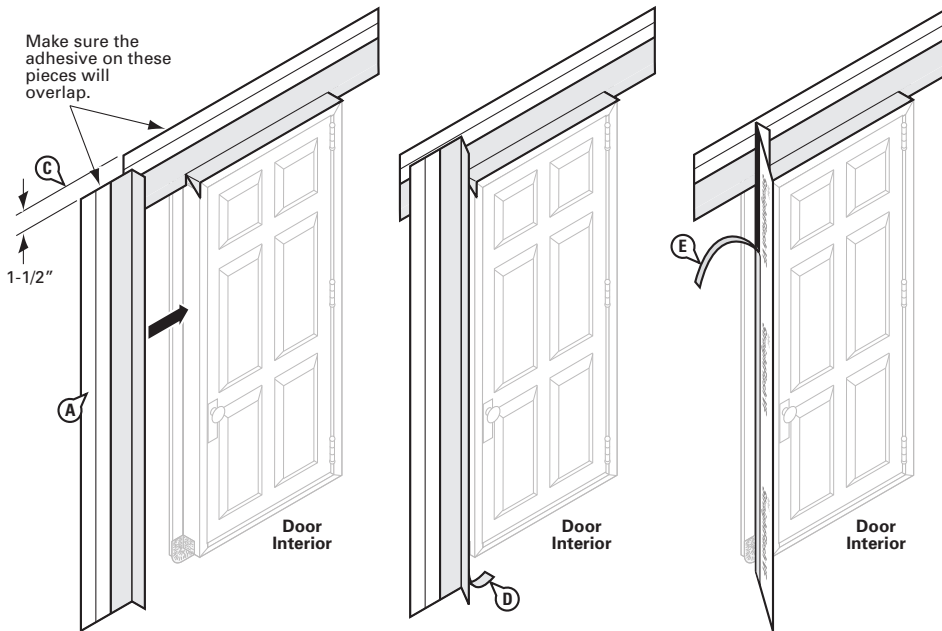

STEP 7

- Beginning at the junction of the jamb and head and beginning at the junction of the jamb and sill, and away from the corner, cut the DuPont™ StraightFlash™ VF along both corners at a 45° angle.
- Fold newly created flaps down flat against the head flashing.
- Fold newly created flaps down onto the head and sill of door frame.

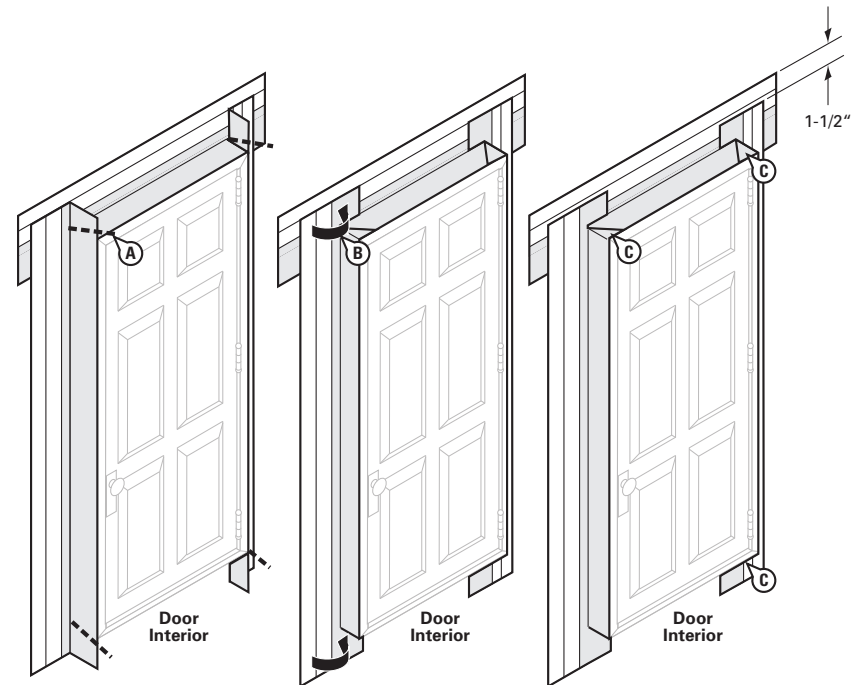

DuPont™ Tyvek® ThermaWrap® R5.0 Installation Guidelines

STEP 8 (OPTIONAL - HIGH PRESSURE SKIRT)

For extreme weather conditions, performance requirements exceeding ASTM E1677, or window/door design ratings of DP45 or greater, see *General Instructions*.

- A. Create the high pressure skirt by cutting a piece of DuPont™ Tyvek® WRB 1" wider than the width of the door opening and approximately 10" in height.
- B. Cut a piece of DuPont™ StraightFlash™ VF to the same width of skirt. Remove release paper from one side of DuPont™ StraightFlash™ VF and adhere to DuPont™ Tyvek® WRB. The skirt may be made with DuPont™ StraightFlash™ VF, DuPont™ StraightFlash™ or DuPont™ Flashing Tape.

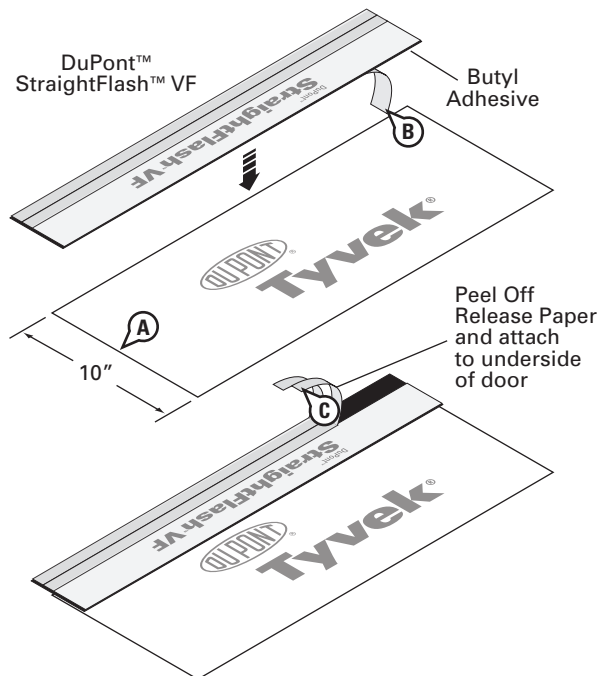

- C. Remove the release paper from the other side of DuPont™ StraightFlash™ VF and adhere the butyl adhesive at the sill skirt to the underside of the door threshold behind the jamb flashing.
- D. Secure edges of the optional skirt with two 4" pieces of DuPont™ StraightFlash™ or DuPont™ Flashing Tape.
- E. Tape the bottom of the optional skirt to allow for drainage and to minimize wind damage during construction.
- F. If sealant is applied to the sill, insure (2) 2" gaps to allow for drainage for every 4' of door using DuPont™ Residential Sealant, or other sealant.

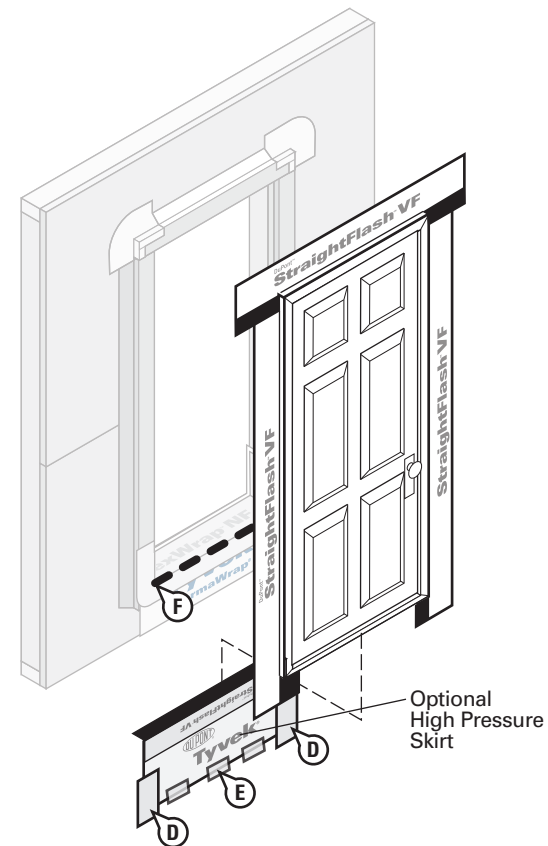

DuPont™ Tyvek® ThermaWrap® R5.0 Installation Guidelines

STEP 9 – DOOR INSTALLATION

- A. Install door according to manufacturer's installation instructions.
- B. Remove the remaining release paper from the DuPont™ StraightFlash™ VF jamb flashing and press firmly to adhere it to the exterior sheathing or framing members.
- C. Remove the release paper at the head and adhere it to the exterior sheathing or framing members.

OPTIONAL: Cover exposed butyl with DuPont™ StraightFlash™, DuPont™ Flashing Tape or DuPont™ Tyvek® Tape.

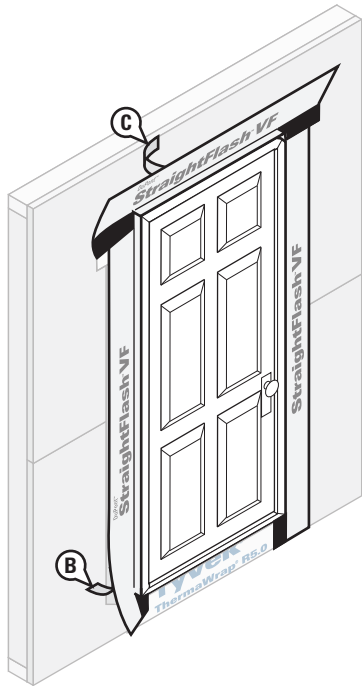

STEP 10 (OPTIONAL)

- A. Cut a piece of metal or vinyl drip cap slightly longer than the width of the door and place a bead of DuPont™ Residential Sealant, DuPont™ Commercial Sealant, or recommended sealant on the rear side. Install the drip cap tight against the door head and cover the top edge with DuPont™ StraightFlash™ or DuPont™ Flashing Tape.

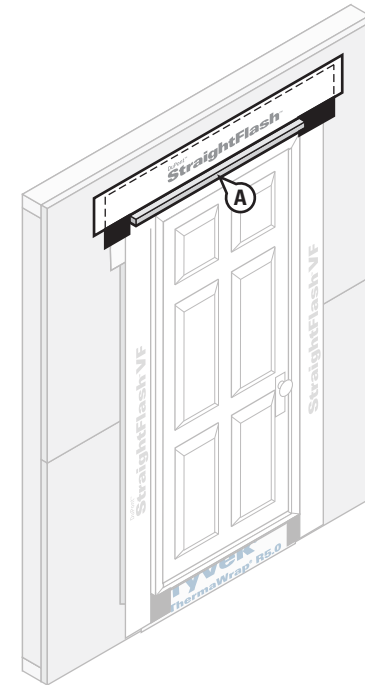

DuPont™ Tyvek® ThermaWrap® R5.0 Installation Guidelines

STEP 11 – EXPOSING THE DOOR

After installing the DuPont™ Tyvek® WRB, cut as shown to expose door and apron. (Refer to the page 12 to install the DuPont™ Tyvek® ThermaWrap® R5.0 properly).

DO NOT CUT THROUGH THE DUPONT™ FLASHING SYSTEMS PRODUCTS OR APRON.

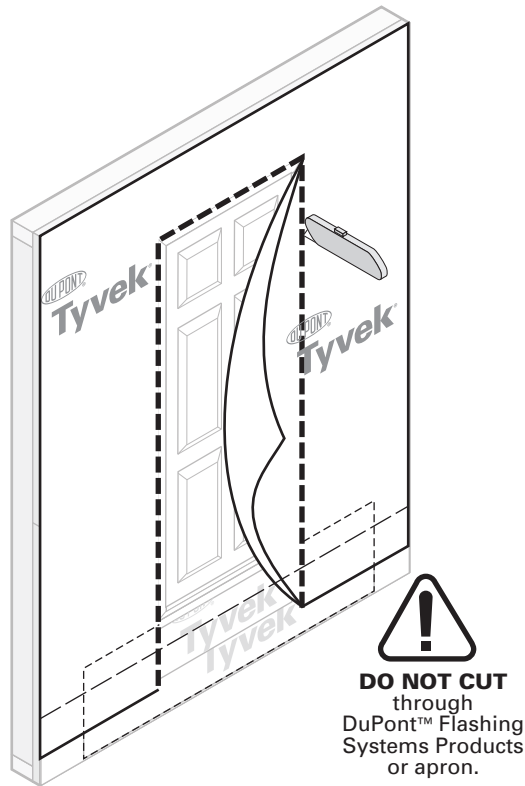

STEP 12 – TERMINATING THE TYVEK® THERMAWRAP® R5.0 AROUND THE WINDOW

- A. Tape seams as shown. **DO NOT TAPE** at bottom of window. At the head, continuous tape seams as shown with DuPont™ Tyvek® Tape.
- B. Lap bottom of apron and the DuPont™ Tyvek® WRB over building materials below for proper shingling.

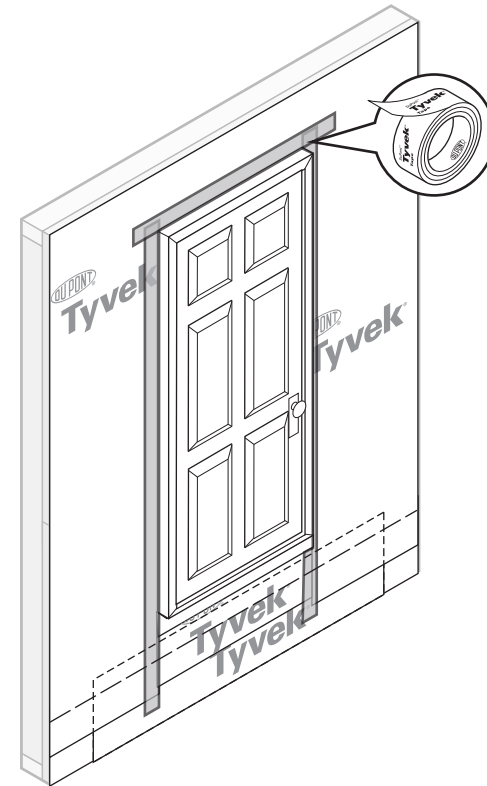

DuPont™ Tyvek® ThermaWrap® R5.0 Installation Guidelines

ALTERNATE TAPE DETAIL

Place a continuous bead of DuPont™ Residential Sealant, DuPont™ Commercial Sealant, or recommended sealant around the jamb and head flashing under the DuPont™ Tyvek® WRB. Press the DuPont™ Tyvek® WRB securely into the sealant.

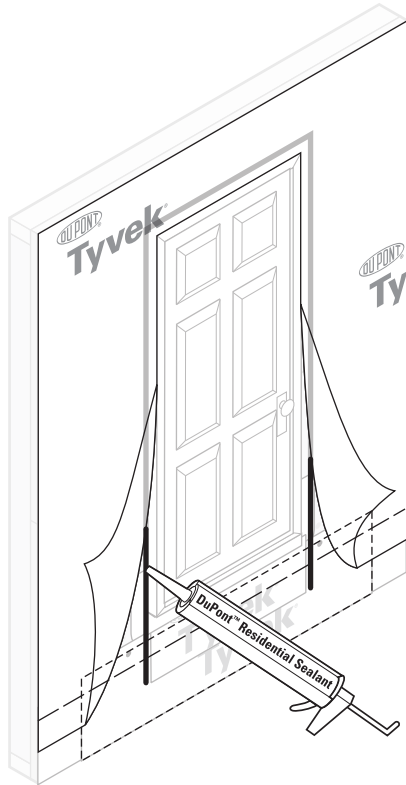

STEP 13

Final Step

- A. When the interior flooring is ready to install, remove release paper and use Folding Option One or Two to form back dam.
- B. Install DuPont™ Residential Sealant, DuPont™ Commercial Sealant, or recommended sealant (and backer rod as necessary) around the window opening at the interior. It is also acceptable to use DuPont™ Window & Door Foam or recommended foam. The seal created by the sealant (and backer rod as necessary) or foam will also serve as a back dam. DuPont™ Residential Sealant or other sealant should be tooled flat to allow the natural curing process to create a concave shape. Be sure that the sealant penetrates the grooves of the DuPont™ FlexWrap™ NF around the sill.

NOTE: Installations that specify a window/door design rating of DP45 or greater require extra precautions. See General Instructions for performance requirements exceeding this design rating.

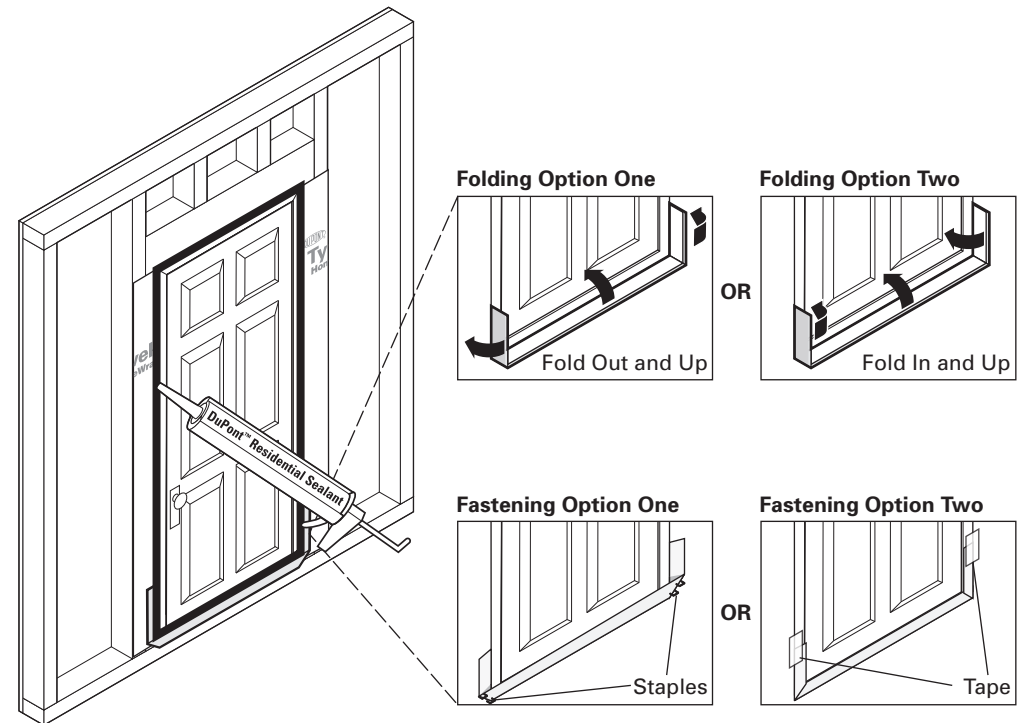

Flashing Pipe Penetrations

Drilling through DuPont™ Tyvek® ThermaWrap® R5.0 will damage the insulation. Use appropriate size boxes to compensate for the thickness of the DuPont™ Tyvek® ThermaWrap® R5.0

STEP 1

Make a small cut in the Tyvek® ThermaWrap® R5.0. Expose wall sheathing and drill hole for pipe.

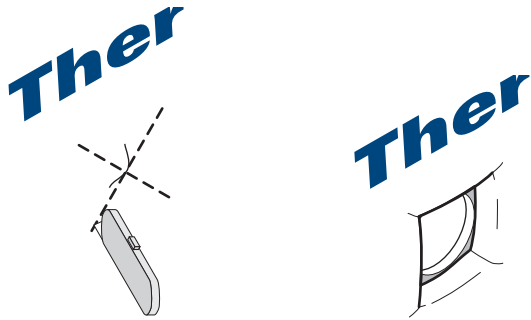

STEP 2

Install pipe and trim Tyvek® ThermaWrap® R5.0 around the perimeter.

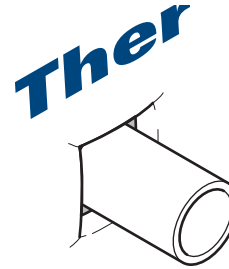

STEP 3

Install DuPont™ Tyvek® FlexWrap® NF starting with a piece at the bottom

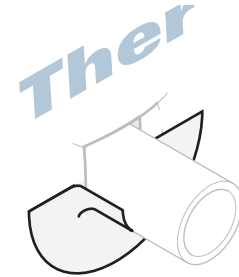

STEP 4

Install a second piece of DuPont™ Tyvek® FlexWrap® NF at the top ensuring it overlaps the bottom piece a minimum of 2”.



STEP 5

Tape a piece of DuPont™ Tyvek® over the DuPont™ FlexWrap™

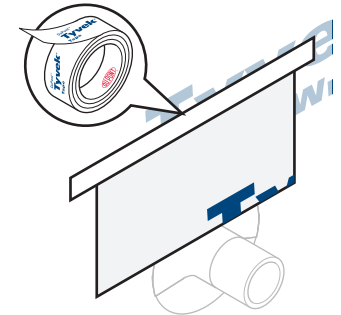

Flashing Electrical Box

NOTE: Different size electrical box or extensions may be required to compensate for thickness of Tyvek® ThermaWrap® R5.0

STEP 1

Make a small cut in the Tyvek® ThermaWrap® R5.0. Expose sheathing and drill hole for wire.

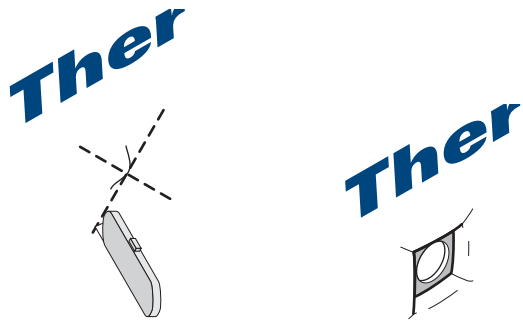

STEP 2

Pull wire through insulation and box. Secure box to the exterior of the structure.

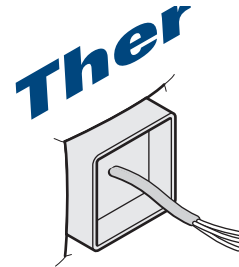

STEP 3

Install DuPont™ Tyvek® FlexWrap® NF starting with a piece at the bottom.

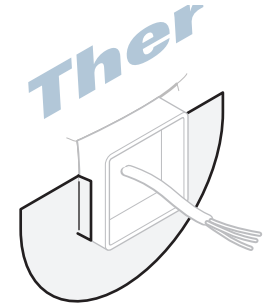

STEP 4

Install a piece of DuPont™ Tyvek® FlexWrap® NF at the top ensuring it overlaps the bottom piece a minimum of 2”.

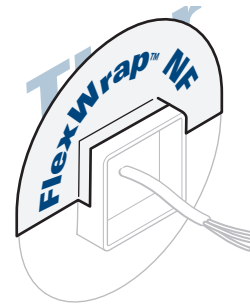

STEP 5

Tape a piece of DuPont™ Tyvek® WRB over the DuPont™ FlexWrap™

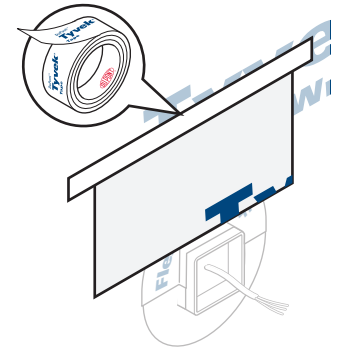

Flashing Dryer Vent

STEP 1

Make a small cut in the Tyvek® ThermaWrap® R5.0. Expose sheathing and drill hole for penetration.

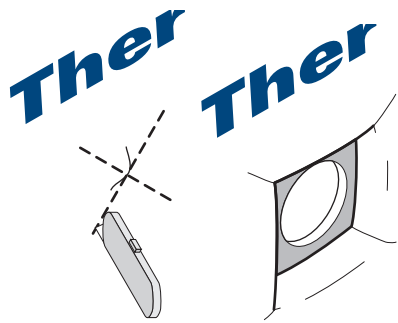

STEP 2

DuPont recommends all penetrations greater than 1 inch in diameter have a bump-out installed to accommodate a nailer for the cladding. Create a bump-out using 2 pieces of DuPont™ Insulated Batten CT and cut the profile of the penetration. Insert the pieces behind the Tyvek® ThermaWrap® R5.0 and secure .

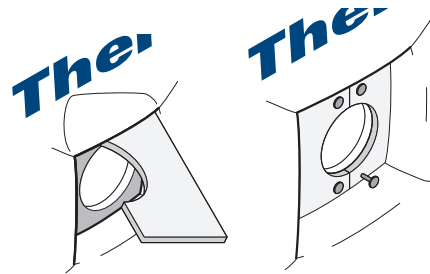

STEP 3

Flash the lower half of the opening using DuPont™ FlexWrap™ NF. The DuPont™ FlexWrap should extend to the back of the opening and a minimum of 2" must extend on to the front of the wall.

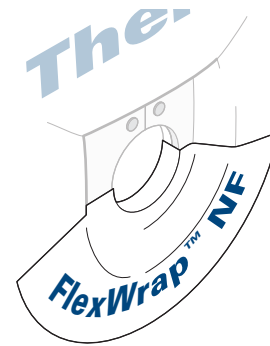

STEP 4

Insert the dryer vent and secure. Flash both sides of the vent followed by the top with DuPont™ Flashing Systems product.

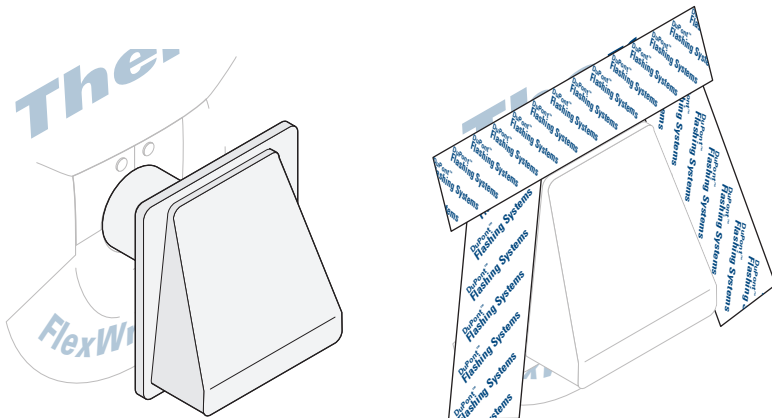

STEP 5

Tape a piece of DuPont™ Tyvek® WRB over the top piece of flashing.

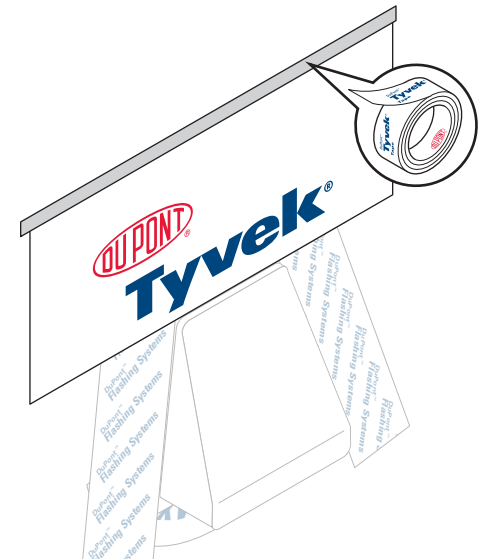

Handling Tears and Holes

During the course of installing Tyvek® ThermaWrap® R5.0, minor tears may occur. Be sure to tape all tears. Tears can easily be covered with DuPont™ Tyvek® Tape (2" or 3") or DuPont™ Flashing Systems Products.

Larger holes (greater than 1") may require cutting a piece of DuPont™ Tyvek® water-resistant barrier (WRB) to cover the hole, maintaining proper shingling. Replace any missing insulation with a piece of Tyvek® ThermaWrap® R5.0 insulation, by removing it from the Tyvek® top sheet.

Cut a slit 2" above the hole and extending a minimum of 2" on each side of the hole. Measure and cut a piece of DuPont™ Tyvek® WRB to fit into the slit and cover the hole. Tuck the cut piece of DuPont™ Tyvek® WRB into the slit. Tape along the perimeter by starting at the bottom of the patch, shingling upper tape over bottom tape.

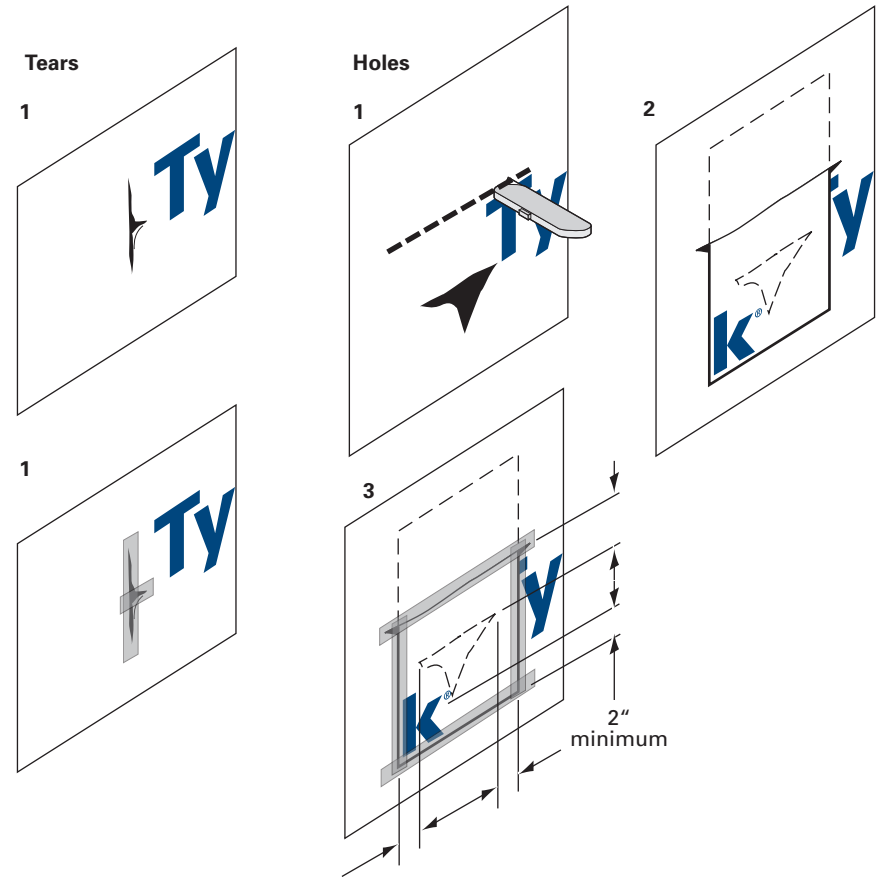

Cladding Installation

Install cladding per manufactures guidelines and code requirements. Fasteners must be 1-1/2" longer to compensate for the thickness of the Tyvek® ThermaWrap® R5.0 and to meet the required penetration into the structural member.

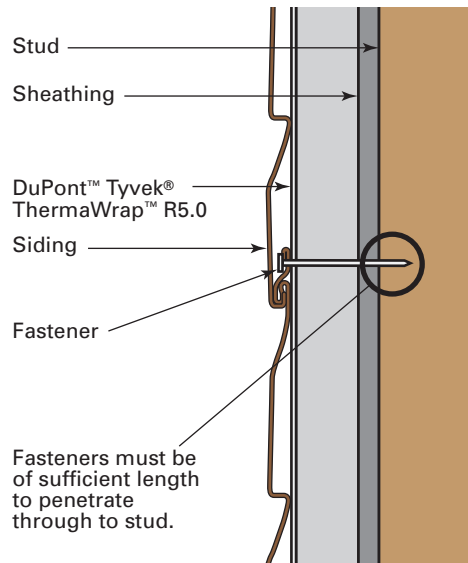

Vinyl Cladding Installation

When installing cladding fasteners, do not compress the DuPont™ Tyvek® ThermaWrap® R5.0. Compressing the product will reduce the thermal resistance. Use the DuPont™ Vinylign™ Nail Depth Regulator to help control the depth of the fastener during vinyl siding installation.

STEP 1

Install trim around windows ,doors, penetrations, interior and exterior corners, gables, etc.

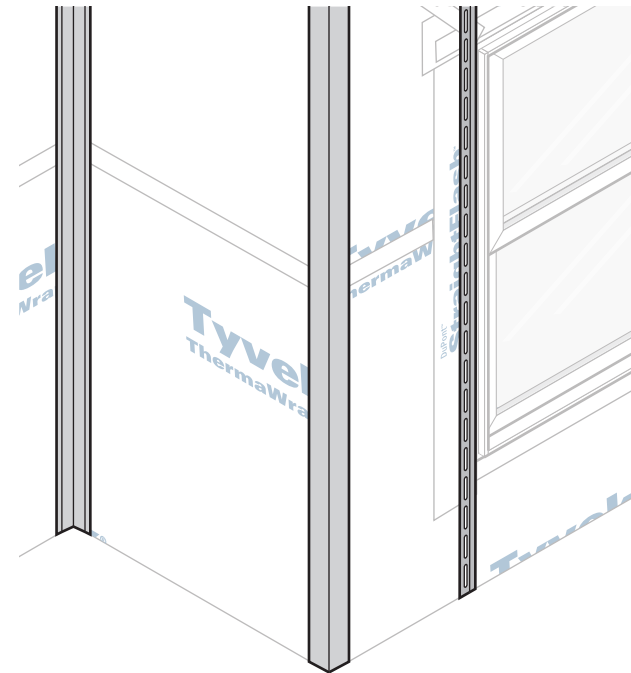

DuPont™ Tyvek® ThermaWrap® R5.0 Installation Guidelines

STEP 2

Install starter strip at base of wall. If alternate bottom of wall detail—termination ledge is used, be sure to not compress the DuPont™ Tyvek® ThermaWrap™ R5.0.



STEP 3

Install cladding. Do not compress DuPont™ Tyvek® ThermaWrap® R5.0.

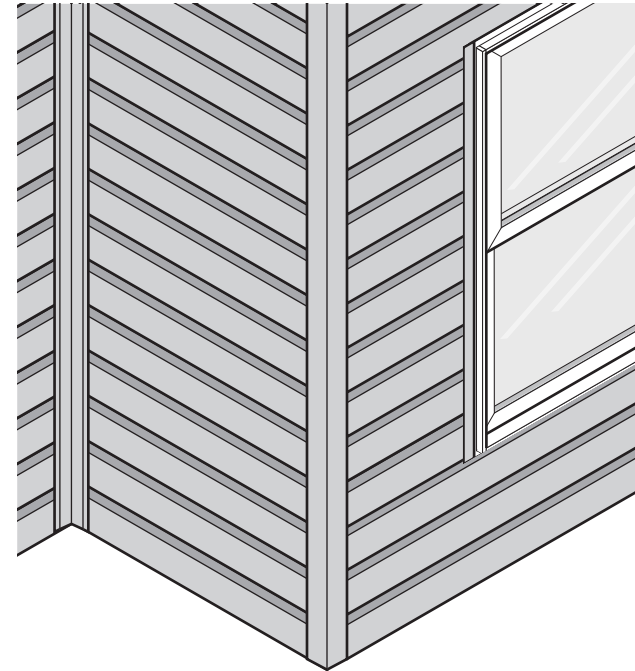

Brick and Stone Installation

1. Install mortar dropping collection device if needed
2. Use standard brick ties and fasteners. The installation of brick ties will compress the Tyvek® ThermaWrap® R5.0 but will not significantly affect the overall R-value of the wall.
3. Install brick

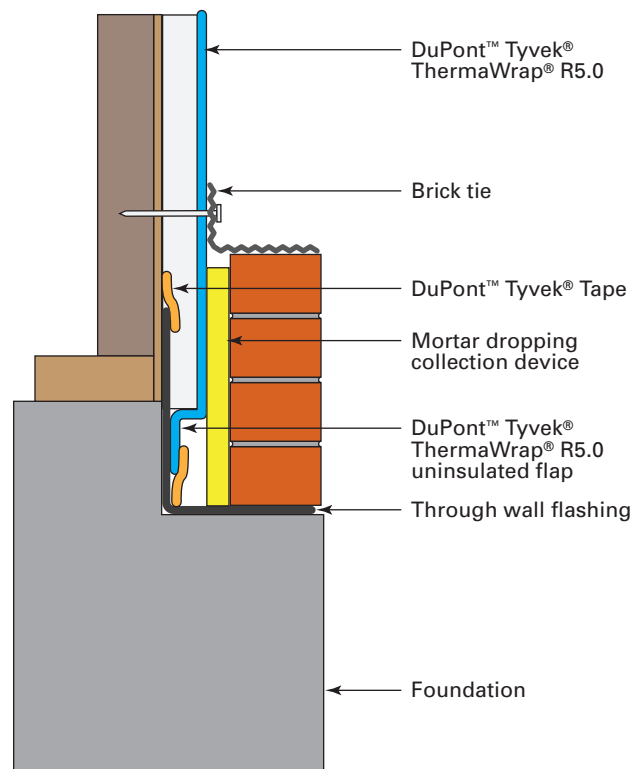

Cladding Transition

INSTALLATION

- A. Install bump-out at transition
- B. Install metal flashing over bump-out
- C. Install DuPont™ flashing on metal flashing/wood sheathing
- D. Refer to page 12 for DuPont™ Tyvek® ThermaWrap® R5.0 installation
- E. Refer to page 55 for cladding installation

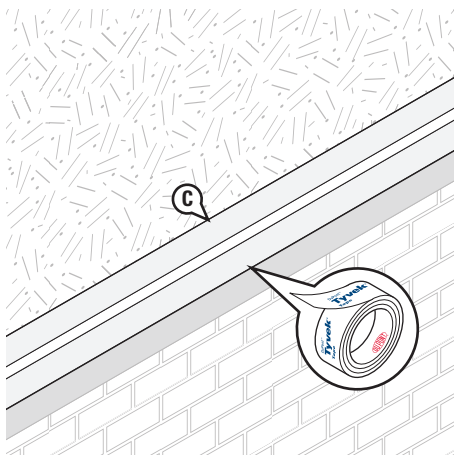
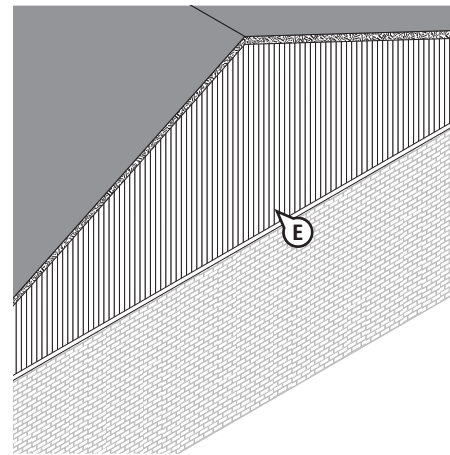
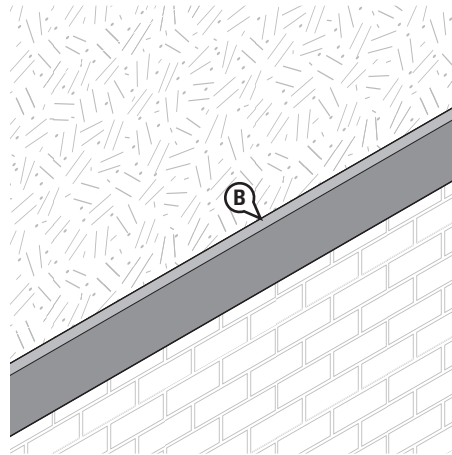
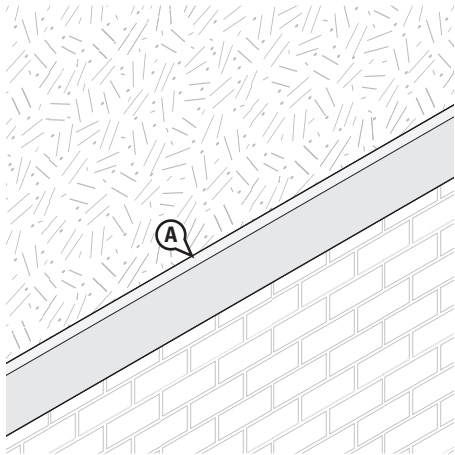

Cladding Considerations

Water-resistive barrier performance is dependent upon the ability of the facade to drain. The following must be considered for specific facades.

Brick

The 2012 International Residential Code (Section R703.7.4.2) requires a nominal 1 inch airspace separating the brick from the water-resistive barrier (WRB). The Brick Industry Association recommends a 1 inch air-space in front of wood stud construction and a 2 inch air-space in front of steel stud construction. Consistent with these requirements and recommendations, DuPont™ Tyvek® WRBs shall be separated from the brick veneer by a nominal 1 inch air-space. Window and door flashing, and through-wall flashing shall be integrated with the DuPont™ Tyvek® WRB layer ensuring proper shingling. For maximum moisture management and drying of the wall system the airspace in front of the DuPont™ Tyvek® WRB shall be vented to the exterior at the top and bottom of the wall. Some types of brick ties will act as additional fasteners for DuPont™ Tyvek® WRBs, and, if installed as soon as practically possible after the DuPont™ Tyvek® WRB, may reduce the required number of fasteners used for the initial attachment of the DuPont™ Tyvek® WRB.

Vinyl Siding

Vinyl Siding is installed directly over DuPont™ Tyvek® WRBs. Vinyl siding shall be installed in accordance with manufacturer's instructions, industry standards and applicable codes, including ASTM D4756-06 Standard Practice for Installation of Rigid Poly(Vinyl Chloride) (PVC) Siding and Soffit. In high wind areas at gable end walls, FEMA recommends vinyl siding be installed over wood sheathing rather than over plastic foam sheathing.

Technical Specifications

DuPont™ Tyvek® WRBs used in construction products are made from 100% flash spunbonded high density polyethylene fibers which have been bonded together by heat and pressure, without binders or fillers, into a tough, durable sheet structure. Additives have been incorporated into the polyethylene to provide ultraviolet light resistance. DuPont requires that DuPont™ Tyvek® ThermaWrap® Rv5.0 be covered within four months (120 days) of installation.

DuPont™ self-adhered flashing products are made from a synthetic rubber adhesive and a laminate of polyethylene film, polypropylene film, elastic fiber, synthetic rubber adhesive, polyurethane adhesive, and a top sheet of flash spunbonded high density polyethylene fibers or polypropylene film. Additives have been incorporated into these materials to provide ultraviolet light resistance. DuPont requires that DuPont™ Flashing Systems products be covered within four months (120 days) of installation.

Warning

DuPont™ Tyvek® air and water barriers are slippery and should not be used in any application where it will be walked on. In addition, because they are slippery, DuPont recommends using kickjacks or scaffolding for exterior work above the first floor. If ladders must be used, extra caution must be taken to use them safely by following the requirements set forth in ANSI Standards 14.1, 14.2 and 14.5 for ladders made of wood, aluminum, and fiberglass, respectively. DuPont™ Tyvek® products are combustible and should be protected from a flame and other high heat sources. DuPont™ Tyvek® products will melt at 275°F (135°C); if the temperature of DuPont™ Tyvek® products reaches 750°F (400°C), it will burn and the fire may spread and fall away from the point of ignition. For more information, call 1-800-44-Tyvek.

DuPont™ self-adhered flashing products and their release paper are slippery and should not be walked on. Remove release paper from work area immediately. DuPont™ Flashing Systems products will melt at temperatures greater than 250°F (121°C). DuPont™ Flashing Systems products are combustible and should be protected from flames and other high heat sources. DuPont™ Flashing Systems products will not support combustion if the heat source is removed. However, if burning occurs, ignited droplets may fall away from the point of ignition. For more information, call 1-800-44-Tyvek.

DuPont™ Residential Sealant is irritating to skin, eyes, and respiratory tract. For proper usage, follow directions stated on the product label. For health information, refer to the Material Safety Data Sheet or call Chemtrec at 1-800-424-9300.

Note

When installed in conjunction with other building materials, DuPont™ self-adhered flashing products must be properly shingled with these materials such that water is diverted to the exterior of the wall system. DuPont™ Tyvek® ThermaWrap® R5.0 is not the primary water barrier. The outer facade is the primary barrier. You must follow facade manufacturer's installation and maintenance requirements for all facade systems in order to maintain water holdout properties and ensure performance of DuPont™ Tyvek® products. Use of additives, coatings or cleansers on or in the facade system may impact the performance of DuPont™ Tyvek® ThermaWrap® R5.0. DuPont™ Tyvek® Weatherization Systems products are to be used as outlined in this installation guideline. DuPont™ Flashing Systems products should only be used to seal penetrations and flash openings in houses or buildings. DuPont™ Flashing Systems products are not to be used in roofing applications. For superior protection against bulk water penetration, DuPont suggests a system combining a quality exterior facade, a good secondary WRB and exterior sheathing, high quality windows and doors, and appropriate flashing materials paying attention to proper installation of each component.

DuPont believes this information to be reliable and accurate. This information may be subject to revision as additional experience and knowledge is gained. It is the user's responsibility to determine the proper construction materials needed on each project.

For complete warranty information, please visit www.Weatherization.Tyvek.com or call 1-800-44-Tyvek.

This information is not intended to be used by others for advertising, promotion or other publication for commercial purposes.

R-value

The higher the R-value, the greater the insulating power. Ask your seller for the fact sheet on R-values. DuPont™ Tyvek® ThermaWrap® R5.0 uses a blanket insulation made of polyester and polyolefin fibers and will produce an R5.0 insulating value at a thickness of 1.5 inches.

For more information about DuPont Weatherization Systems, please call 1-800-44-Tyvek or visit us at www.thermawrap5.tyvek.com



Tyvek.