



DuPont™
FlexWrap

DuPont™
StraightFlash VF

DuPont™
StraightFlash

DuPont™
Commercial Sealant

DuPont™
FlexWrap™ NF

DuPont Flashing Systems Commercial Installation Guidelines

METHODS FOR SUPERIOR PROTECTION
AGAINST AIR AND WATER INTRUSION



Tyvek.

Table of Contents

Applicable Products	2
Required Materials	2
Optional Materials	3
DuPont Recommended Primers.....	3
DuPont Recommended Fasteners	3
General Instructions	3
Surface Preparation for DuPont™ Thru-Wall Flashing	4
Installation Instructions AFTER Water-Resistive Barrier (WRB) is Installed	
Non-Flanged Aluminum Window.....	5
Non-Flanged Aluminum Window with Lintel and Brick Facade.....	15
Brick Mold Window	29
Integral Flanged Aluminum Window	35
Non-Flanged Aluminum Window using DuPont™ StraightFlash™ VF	41
Storefront Window on a Slab.....	48
Storefront Window on a Knee Wall	54
Installation Instructions for DuPont™ Thru-Wall Flashing	
Window Head.....	61
Base of Wall With Outside Corner.....	63
DuPont™ Thru-Wall Flashing—DuPont™ Tyvek® Interface.....	64
Base of Wall.....	64
Shelf Angle	64
Parapet Wall.....	65
Penetrations	66

Applicable Products

DuPont Flashing Systems products

PRODUCT	DIMENSIONS	AREA
DuPont™ FlexWrap™	7 in x 75 ft	43.7 sq ft
	9 in x 75 ft	56.2 sq ft
	9 in x 250 ft	187.5 sq ft
DuPont™ FlexWrap™ NF	6 in x 75 ft	37.50 sq ft
	9 in x 75 ft	56.20 sq ft
DuPont™ StraightFlash™	4 in x 150 ft	50 sq ft
	9 in x 125 ft	93.75 sq ft
DuPont™ StraightFlash™ VF	6 in x 125 ft	62.5 sq ft
DuPont™ Thru-Wall Flashing	12 in x 75 ft	75 sq ft
	18 in x 75 ft	112.5 sq ft
	24 in x 75 ft	150 sq ft
	36 in x 75 ft	225 sq ft

Accessories

PRODUCT	TYPE	PER BOX
DuPont™ End Dams	4"	50 (25 left/25 right)
DuPont™ End Dams	6"	50 (25 left/25 right)
DuPont™ Corners	Inside	25
DuPont™ Corners	Outside	25

Necessary Materials

- DuPont Flashing Systems
- DuPont™ Tyvek® Tape
- DuPont™ Thru-Wall Flashing
- DuPont™ Corners (Inside and Outside)
- DuPont™ End Dams
- DuPont™ StraightFlash™, DuPont™ FlexWrap™, or DuPont™ Tyvek® Tape

Recommended Materials

- DuPont™ Tyvek® Wrap Cap Fasteners
- Backer Rod
- Brushes for Surface Preparation
- J-Roller
- Compatible Primers and Sealants
- DuPont™ Commercial Sealant
- “L” shaped back dam is a 3/4” corner guard (used on interior gypsum)

Required Materials Warranty

If interested in receiving warranty coverage, please see DuPont Weatherization Systems products 10 year limited warranty for buildings less than 5 stories and DuPont Weatherization Systems products 10 Year Limited Warranty for buildings greater than 4 stories.

DuPont Recommended Primers* (Flashing Only)

MANUFACTURER	PRODUCT NAME
3M	Hi-Strength 90
Denso	Butyl Primer (spray or can)
Henkel	SIA 655
Henkel	Permagrip® 105™
ITW TACC	STA'PUT SPH

* Apply per manufacturers' guidelines. DuPont assumes no liability in use of recommended products; installers need to evaluate suitability of recommended products in their end-use applications.

DuPont Recommended Fasteners*

MANUFACTURER	PRODUCT NAME
DuPont	DuPont™ Tyvek® Wrap Cap nails
DuPont	DuPont™ Tyvek® Wrap Cap screws
DuPont	DuPont™ Tyvek® Wrap Cap staples (for Stinger™)**

* Apply per manufacturers' guidelines. DuPont assumes no liability in use of recommended products; installers need to evaluate suitability of recommended products in their end-use applications.

** Not recommended with foam sheathing board or exterior gypsum.

General Instructions

DuPont Flashing Systems products should be installed on clean, dry surfaces that are free of frost. Wipe surfaces to remove moisture, dirt, grease and other debris that could interfere with adhesion.

Apply pressure along entire surface for a good bond using a J-roller or firm hand pressure.

Remove all wrinkles and bubbles by smoothing surface and repositioning as necessary.

When flashing the sill area for windows and doors, DuPont recommends the use of 7" wide DuPont™ FlexWrap™ for 2" x 4" framing and 9" wide DuPont™ FlexWrap™ for 2" x 6" framing. When rigid back dams are required or desired, an option would be to use a ¾" corner guard (back dam) cut to the length of the sill and nail into place on the interior edge of the sill prior to installation of DuPont™ FlexWrap™. Then install DuPont™ FlexWrap™ over sill and corner guard back dam.

Door and window rough sill framing must be level or slightly sloped to the exterior to ensure proper drainage to the exterior. Please contact your local DuPont™ Tyvek® Specialist for additional information and installation instructions.

DuPont™ Commercial Sealant should be tooled flat to allow the natural curing process to create a concave joint.

DuPont Flashing Systems Commercial Installation Guidelines

DO NOT STRETCH DuPont™ FlexWrap™ when installing along sills or jambs. DuPont™ FlexWrap™ is only intended to be stretched when covering corners or curved sections.

DuPont™ Flashing Systems products perform best when installed at temperatures above 25°F (-4°C).

Avoid placing DuPont™ Tyvek® Wrap Caps where flashing will be installed; however, DuPont™ Tyvek® Wrap Caps can be applied over the flashing.

Where buildings could be exposed to extreme weather conditions (ie. sustained wind-driven rain above 50mph), install a high pressure skirt to help prevent water intrusion at the sill.

For high pressure design loads, the use of DuPont™ Tyvek® StraightFlash™ with wrap cap screws is required to secure the head flap of the windows.

Priming is generally not required for adhering DuPont Flashing Systems products to most common building materials. However, adverse weather conditions or cold temperatures may require use of a primer to promote adhesion. Additionally, concrete, masonry, and fiber-faced exterior gypsum board require the use of recommended primers. For primer recommendations, see page 3.

Priming is required for DuPont™ Thru-Wall Flashing.

Surface Preparation for DuPont™ Thru-Wall Flashing

Substrate surface must be smooth, clean, dry, and free from voids, loose substrate, protrusions, or any material that would hinder adhesion of the flashing.

Clean the surface with a clean dry cloth or brush.

Follow primer manufacturers' guidelines for appropriate coverage and drying times.

Storage for DuPont™ Thru-Wall Flashing

DuPont™ Thru-Wall Flashing should be protected from rain and physical damage under cover at the job site.

Optimum storage temperature 50°F to 90°F.

Freeze-thaw durable. Storage temperatures should not exceed 120°F.

Environmental Conditions for DuPont™ Thru-Wall Flashing

DuPont™ Thru-Wall Flashing should not be applied to moist or damp surfaces.

DuPont™ Thru-Wall Flashing can be applied with an air and surface temperature of 32°F or higher.

For additional guidelines and suggested sealants, please call 1-800-44-Tyvek (800-448-9835), visit our website at www.construction.tyvek.com, or consult your local DuPont™ Tyvek® Specialist.

Installation Methods for DuPont Flashing Systems products AFTER DuPont™ Tyvek® Weather Barrier is Installed

Non-Flanged Aluminum Window

Method applies to following products:

DuPont™ StraightFlash™

DuPont™ FlexWrap™

DuPont™ FlexWrap™ NF

STEP 1

A. Cut rough opening in sheathing for window. Ensure that sheathing is cut flush with, or slightly below the sill framing to allow for positive drainage.

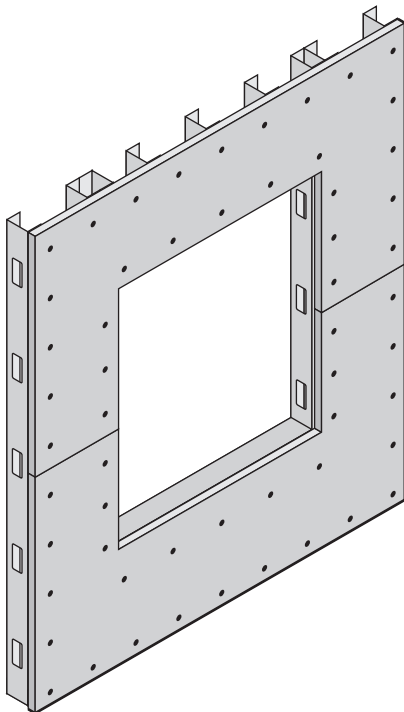

STEP 2

A. Wrap wall as shown in Installation Guidelines for DuPont™ Tyvek® weather barrier that can be found at www.construction.tyvek.com.

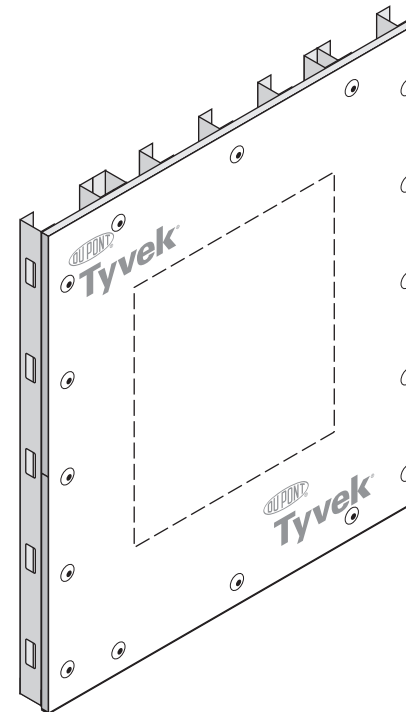

DuPont Flashing Systems Commercial Installation Guidelines

STEP 3

Prepare weather barrier for window installation.

- Cut an opening in the DuPont™ Tyvek® weather barrier using a square cut around the perimeter of the rough opening.
- Cuts should be made along the dashed indicated lines. (Ensure that the DuPont™ Tyvek® weather barrier is cut flush with the sheathing and is not wrapped into the rough opening.)
- Cut a head flap at 45° angle to expose 8" of sheathing to allow for head flashing installation.

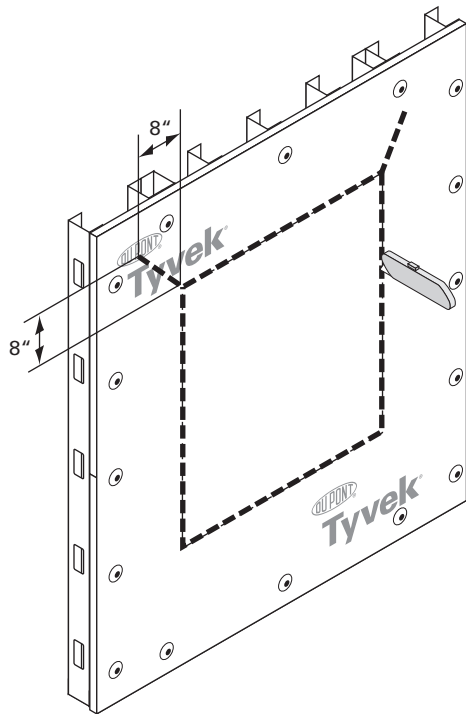

STEP 4

- Flip the head flap up to expose the sheathing and temporarily secure with tape.
- Temporarily secure DuPont™ Tyvek® weather barrier with DuPont™ Tyvek® Tape around rough opening before flashing is installed to help facilitate flashing installation.

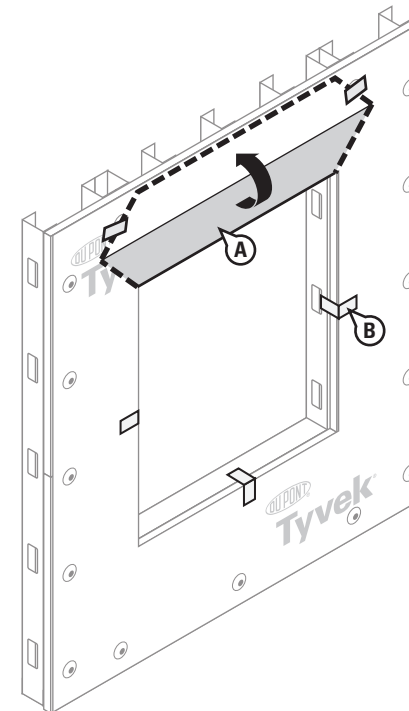

DuPont Flashing Systems Commercial Installation Guidelines

STEP 5

- A. Prepare the sill flashing by cutting a piece of DuPont™ FlexWrap™ that is at least 12" longer than sill length. Use 7" DuPont™ FlexWrap™ for 2 x 4 framing and 9" DuPont™ FlexWrap™ for 2 x 6 framing.
- B. Inspect installation surface to ensure surface is free of dirt or substances that could interfere with adhesion as well as any sharp protrusions.

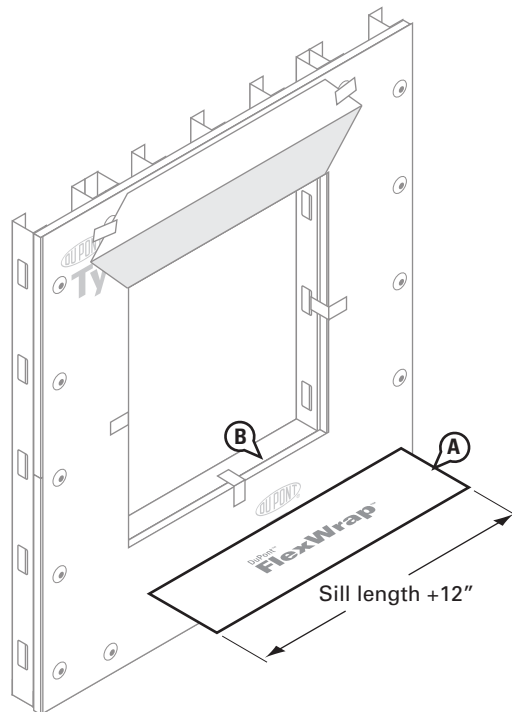

STEP 6

- A. Install the sill flashing. Remove the largest strip of release paper, align the flashing with the interior edge of sill, and install into rough opening across sill and up jambs (min 6"). Apply working from the middle of the sill towards the sides. Secure DuPont™ FlexWrap™ or DuPont™ FlexWrap™ NF tightly into the corners by first working in along the sill before adhering up the jambs. When using DuPont™ FlexWrap™ NF, fasteners are not required.

DO NOT STRETCH MATERIAL ALONG THE SILL OR JAMBS.

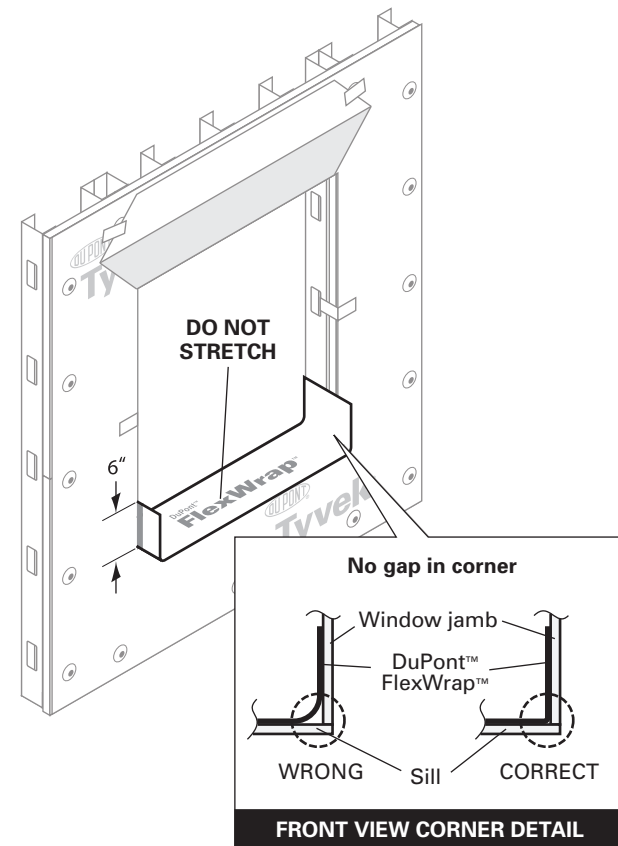

DuPont Flashing Systems Commercial Installation Guidelines

STEP 7

- A. Remove second half of the release paper.
- B. Fan DuPont™ FlexWrap™ at bottom corners and adhere onto face of wall.
- C. Firmly press sill flashing to ensure full adhesion on all surfaces. Eliminate wrinkles and bubbles by smoothing surface and repositioning as necessary.

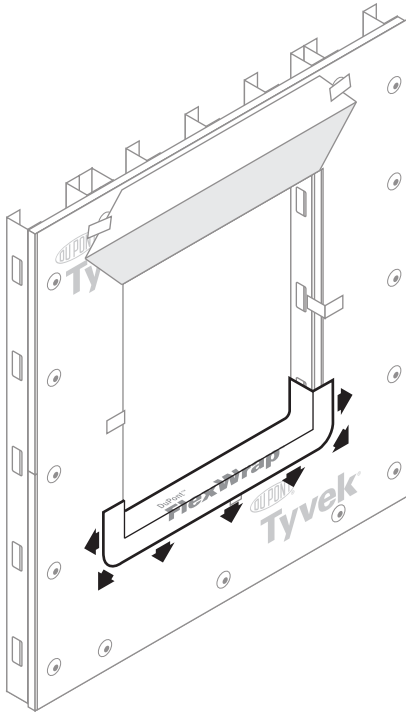

STEP 8

- A. Use sufficient DuPont™ Tyvek® Wrap Cap fasteners to temporarily secure the outer edge of the flashing at the lower corners. (Self tapping Wrap Cap screws are recommended for steel stud framing.) Flashing bond will strengthen over time. When using DuPont™ FlexWrap™ NF, fasteners are not required.

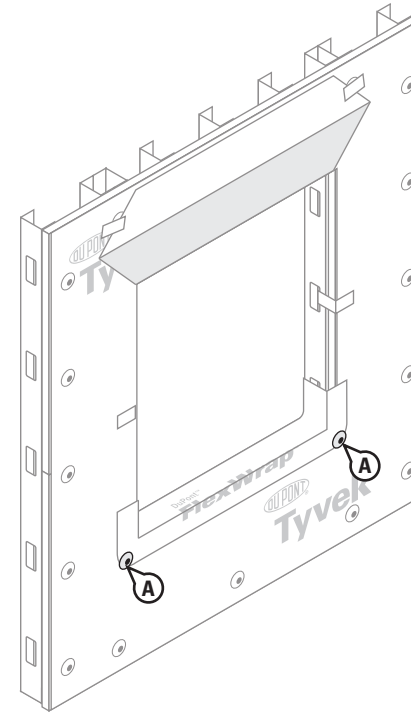

DuPont Flashing Systems Commercial Installation Guidelines

STEP 9

- A. Wrap 9" DuPont™ StraightFlash™ into the rough opening at each jamb and onto wall face. The flashing should align with the interior edge of the jamb framing. Cut the jamb flashing the vertical length of the rough opening.
- B. Jamb flashing should be long enough to overlap the sill flashing by at least 2" and be overlapped by future head flashing by at least 2".

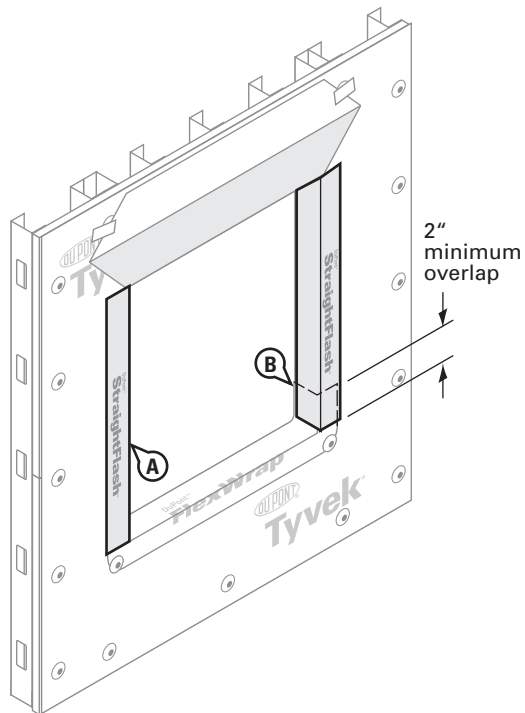

STEP 10

- A. Apply DuPont recommended primer to the top of the jambs and exposed sheathing.

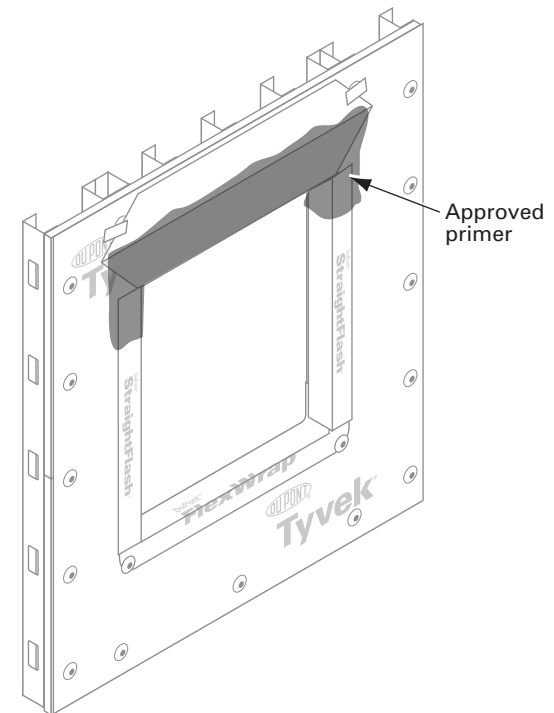

DuPont Flashing Systems Commercial Installation Guidelines

STEP 11

- A. Adhere DuPont™ FlexWrap™ to the head using the same installation process as shown in steps 6 and 7 for the sill flashing. Make sure the DuPont™ FlexWrap™ is cut long enough to overlap the jamb flashing by at least 2”.
- B. Use sufficient DuPont™ Tyvek® Wrap Cap fasteners to temporarily secure the outer edge of the flashing at the upper corners. (Commercial Wrap Cap screws are recommended for steel stud framing.) Flashing bond will strengthen over time. When using DuPont™ FlexWrap™ NF, fasteners are not required.

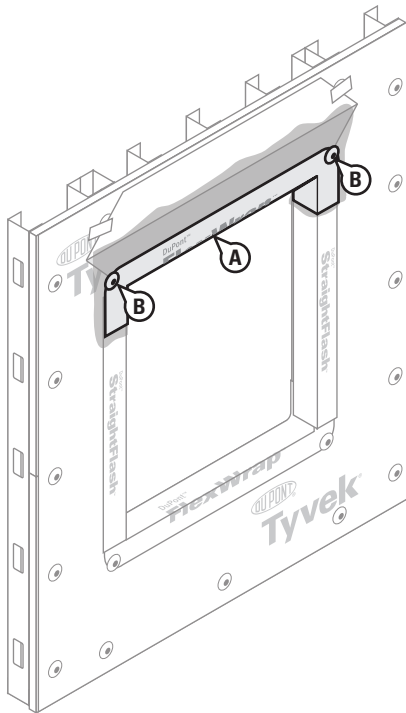

STEP 12

- A. If angled caulk stops are used to contain perimeter sealant, they should be attached to window along side jambs and head prior to installation. The sill will be left open prior to window installation to allow for drainage of incidental moisture.

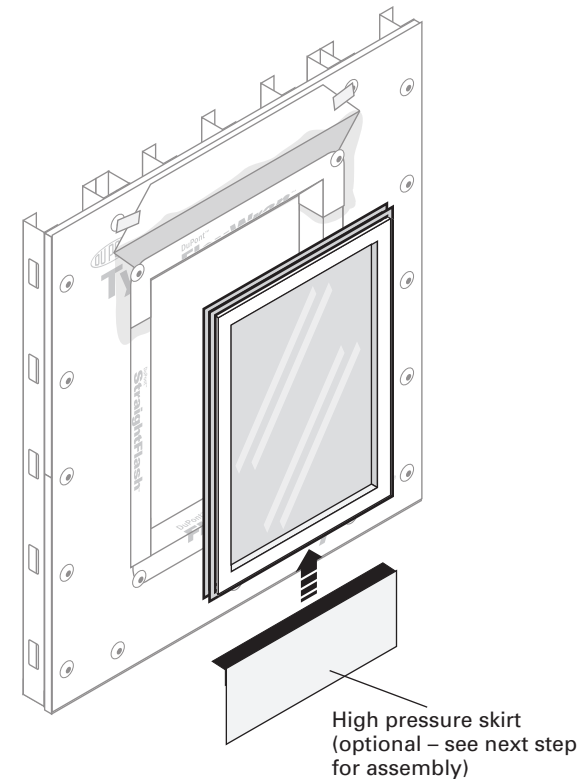

DuPont Flashing Systems Commercial Installation Guidelines

STEP 12 – OPTIONAL

Where buildings could be exposed to extreme weather conditions (ie. sustained wind driven rain above 50 mph). As a best practice, DuPont recommends installing a high pressure skirt to help prevent water intrusion at the sill. Attach the high pressure skirt to the underside of the window prior to installing the window in opening.

- A. Create the high pressure skirt by cutting a piece of DuPont™ Tyvek® weather barrier 1" wider than the width of window opening and approximately 10" in depth.
- B. Attach skirt to underside of window using a piece of 4" DuPont™ StraightFlash™ cut to the same width as the skirt.

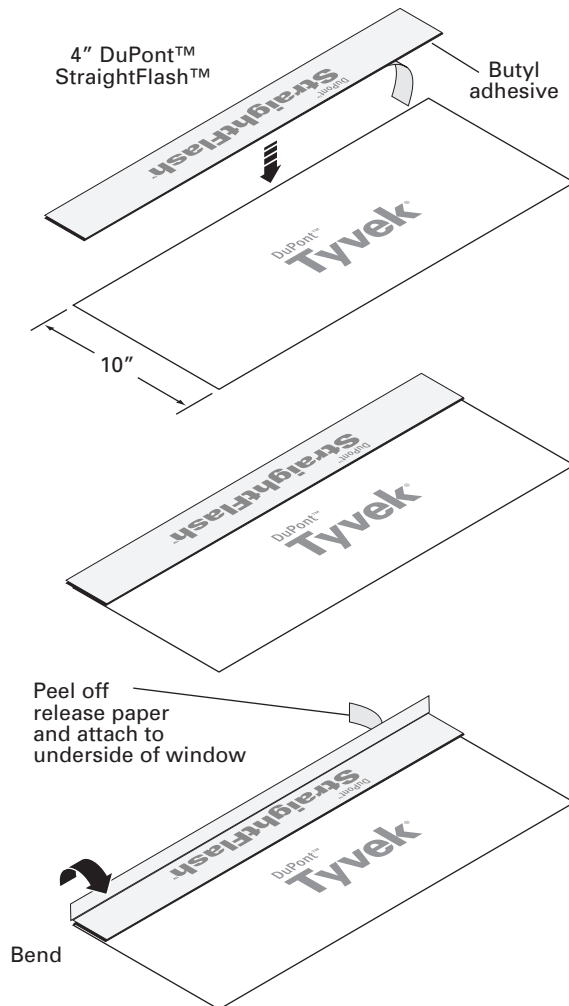

STEP 13

- A. Install window per manufacturer installation instructions.

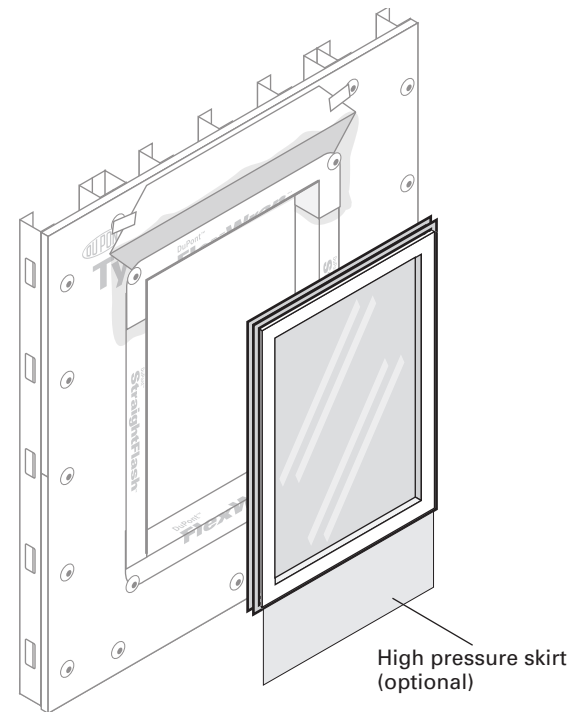

DuPont Flashing Systems Commercial Installation Guidelines

STEP 14

- A. Secure sides of high pressure skirt to weather barrier with DuPont™ StraightFlash™ and skip tape bottom with DuPont™ Tyvek® Tape or 4" DuPont™ StraightFlash™. Skip taping provides weeps that allows drainage behind the skirt.

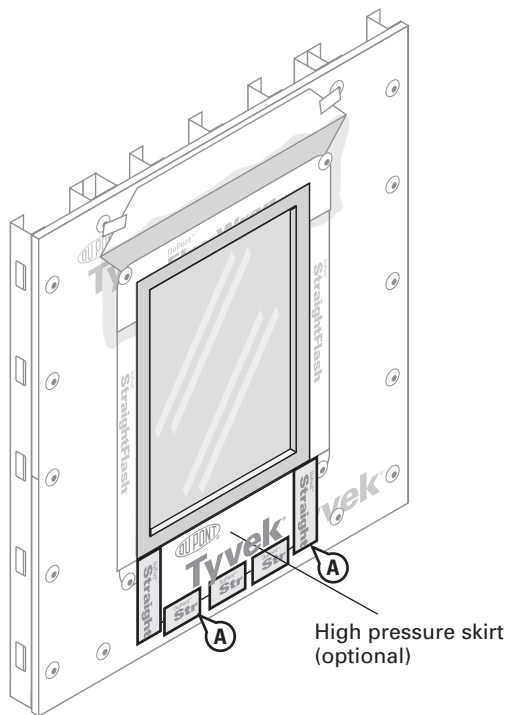

STEP 15

- A. As a best practice for high exposure areas, install metal drip cap above the head joint when specified.
- B. Apply a strip of 4" DuPont™ StraightFlash™ over the drip cap.

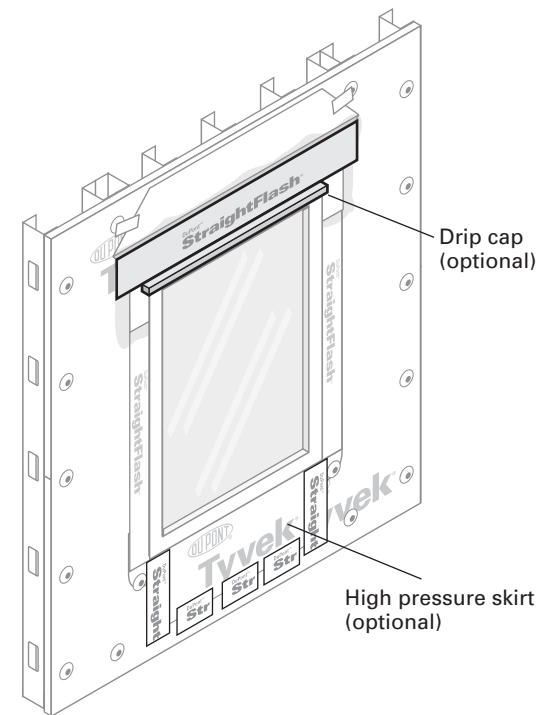

DuPont Flashing Systems Commercial Installation Guidelines

STEP 16

- A. Flip down the head flap and adhere 4" DuPont™ StraightFlash™ over the diagonal seams.
- B. Tape along the top of the window with 3" DuPont™ Tyvek® Tape or 4" DuPont™ StraightFlash™. (See General Instructions for when 3" DuPont™ Tyvek® Tape is allowed).
- C. Install remaining DuPont™ Tyvek® Wrap Caps at head per the recommended spacing (every 12" to 18" depending on the vertical stud line).
- D. Install DuPont™ Tyvek® Wrap Caps at appropriate spacing over skirt.

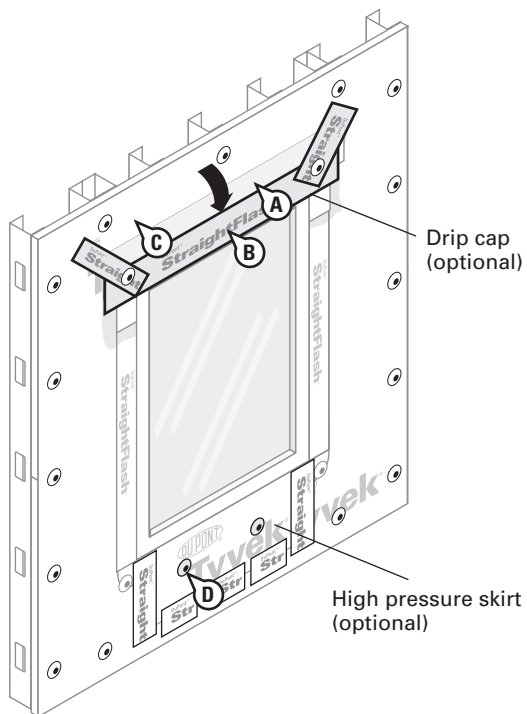

STEP 17

Interior View

- A. Create a continuous perimeter seal with backer rod and DuPont™ Commercial Sealant or recommended sealant on window interior to resist air and water infiltration.

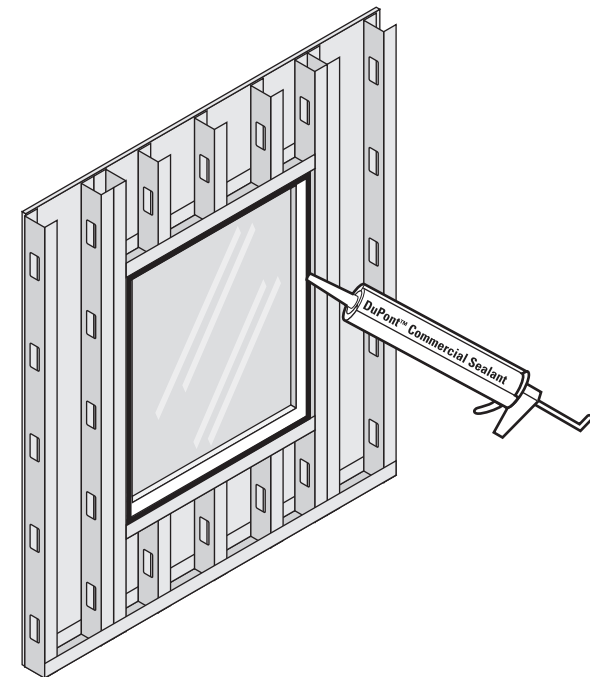

DuPont Flashing Systems Commercial Installation Guidelines

STEP 18

- A. While the DuPont™ Commercial Sealant or recommended sealant is still wet. As a best practice, install an “L” shaped back dam cut the width of the rough opening so that it contacts the sealant bead and rear of window. Seal by applying DuPont™ Commercial Sealant or recommended sealant along 4 sides of the exposed back dam. OPTIONAL: Apply DuPont™ Commercial Sealant or recommended sealant along all four sides in lieu of back dam. Note: For alternate back dam see the Brick Mold Installation Guide. Steps 2 and 7, later in this document.

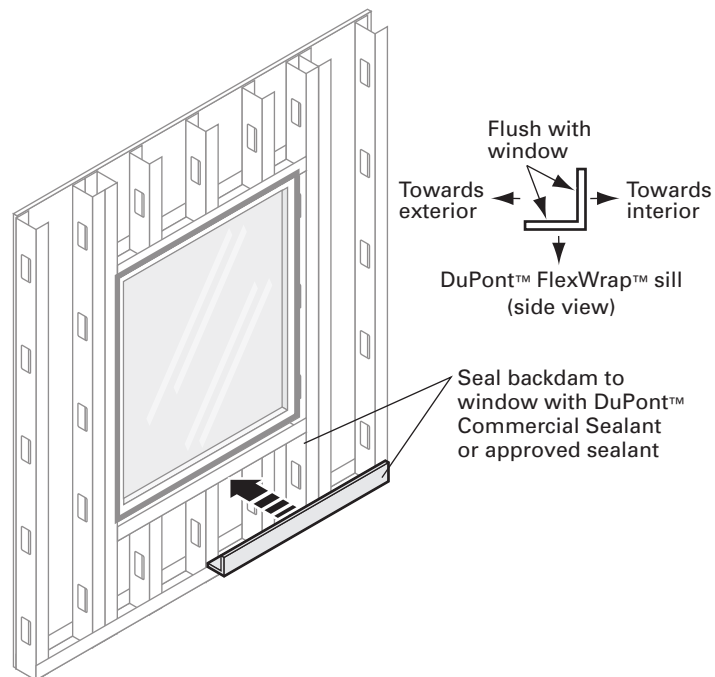

STEP 19

- A. Install retention clips around the window to permanently secure it in the rough opening as recommended by window manufacturer to complete installation.
- B. When the facade is complete, place a continuous sealant bead integrating the window to the facade.

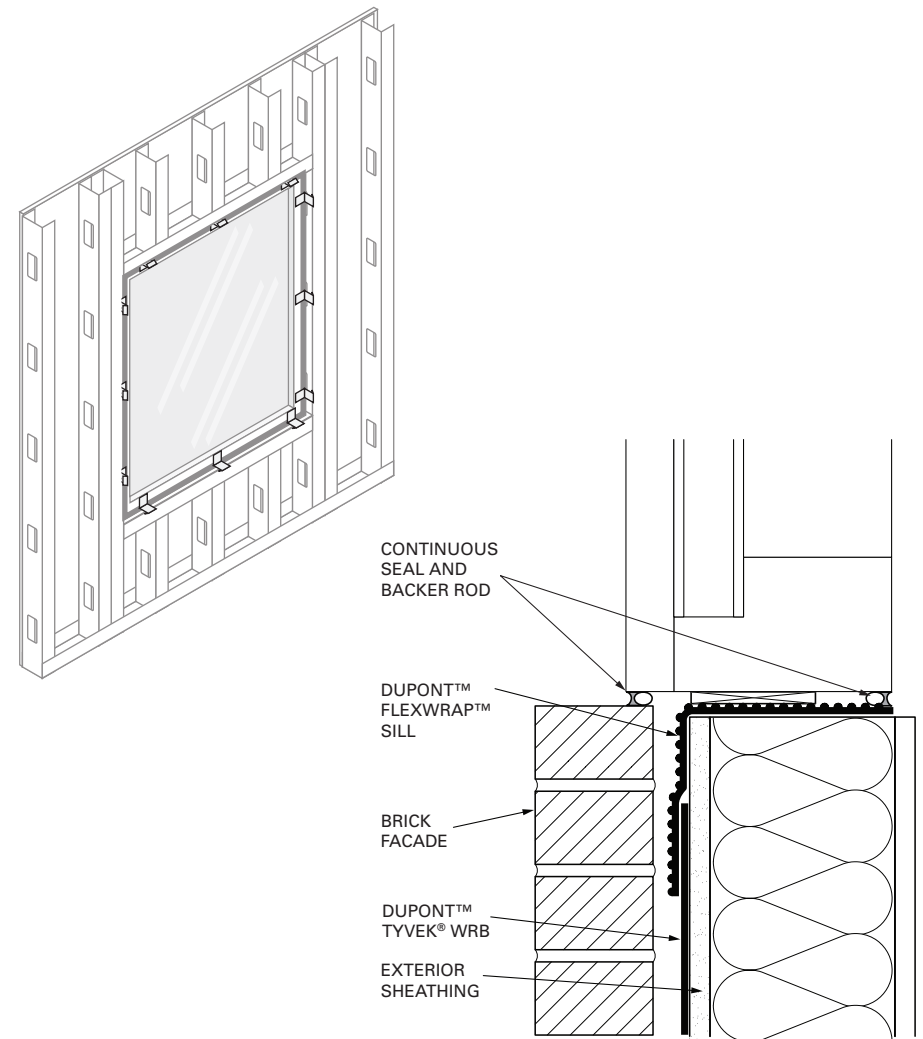

Non-Flanged Aluminum Window with Lintel and Brick Facade

Method applies to following products:

DuPont™ StraightFlash™

DuPont™ FlexWrap™

DuPont™ FlexWrap™ NF

STEP 1

A. Cut rough opening in sheathing for window. Ensure that sheathing is cut flush with, or slightly below the sill framing to allow for positive drainage.

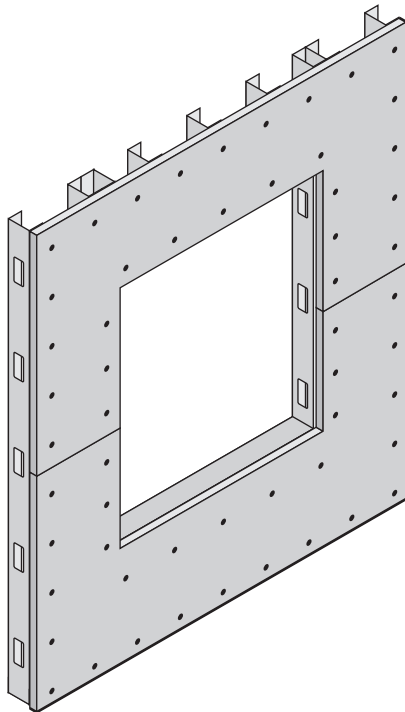

STEP 2

A. Wrap wall as shown in Commercial Installation Guidelines for DuPont™ Tyvek® Weather Barrier Systems that can be found at www.construction.tyvek.com.

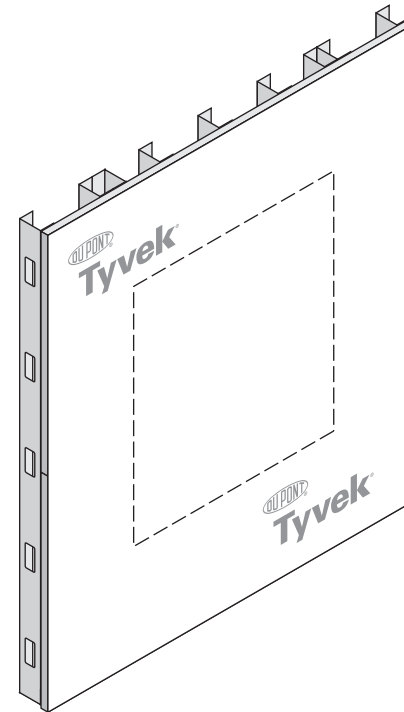

DuPont Flashing Systems Commercial Installation Guidelines

STEP 3

- Cut an opening in the DuPont™ Tyvek® weather barrier using a full cut out around the perimeter of the opening.
- Temporarily secure DuPont™ Tyvek® weather barrier with DuPont™ Tyvek® Tape around rough opening before flashing is installed to help facilitate flashing installation.
- Prepare the sill flashing by cutting a piece of DuPont™ FlexWrap™ or DuPont™ FlexWrap™ NF that is at least 12" longer than sill length. Use 7" DuPont™ FlexWrap™ for 2x4 framing and 9" FlexWrap™ for 2x6 framing. When using DuPont™ FlexWrap™ NF, fasteners are not required.
- Inspect installation surface to ensure surface is free of dirt or substances that could interfere with adhesion as well as any sharp protrusions.

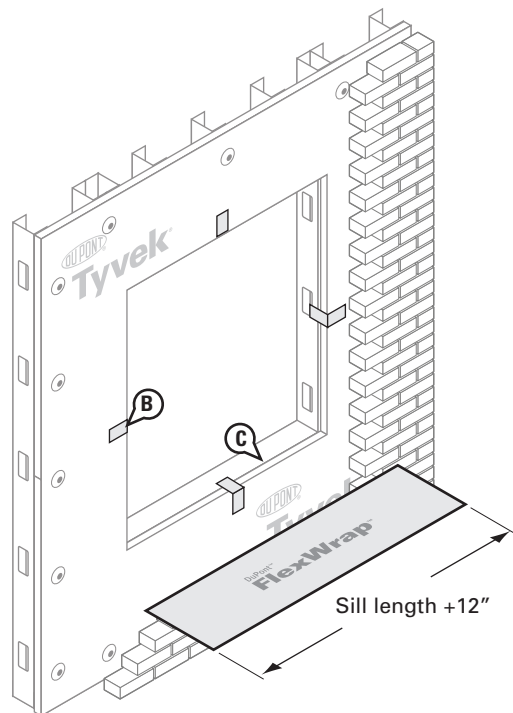

STEP 4

- Install the sill flashing. Remove the largest strip of release paper, align the flashing with the interior edge of sill, and install into rough opening across sill and up jambs (min 6"). Apply working from the middle of the sill towards the sides. Secure DuPont™ FlexWrap™ tightly into the corners by first working in along the sill before adhering up the jambs.

DO NOT STRETCH MATERIAL ALONG THE SILL OR JAMBS.

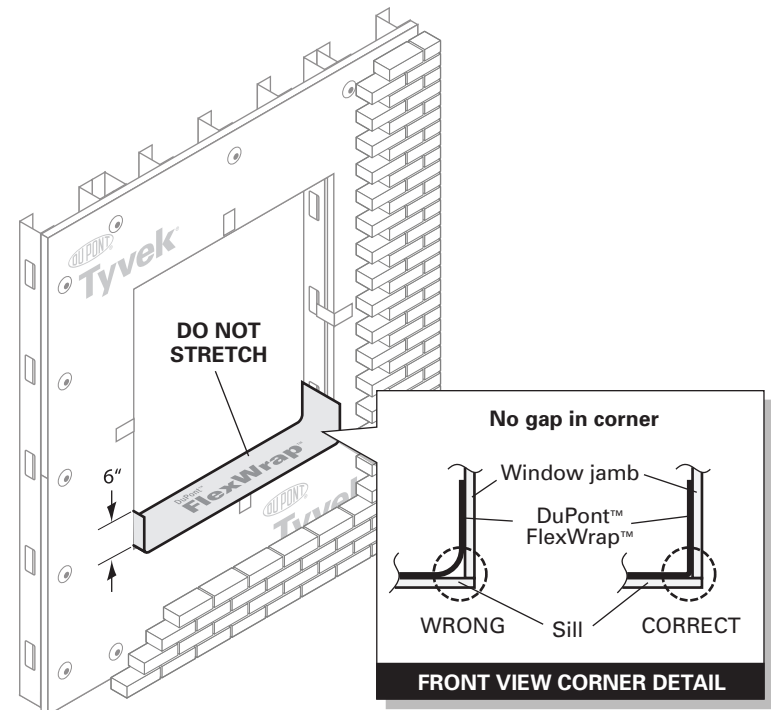

DuPont Flashing Systems Commercial Installation Guidelines

STEP 5

- A. Remove second half of the release paper.
- B. Fan DuPont™ FlexWrap™ or DuPont™ FlexWrap™ NF at bottom corners and adhere onto face of wall. When using DuPont™ FlexWrap™ NF, fasteners are not required.
- C. Firmly press sill flashing to ensure full adhesion on all surfaces. Eliminate wrinkles and bubbles by smoothing surface.

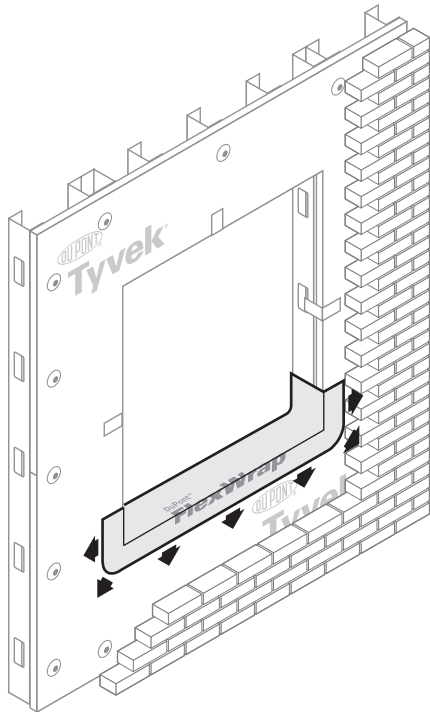

STEP 6

- A. Use sufficient DuPont™ Tyvek® Wrap Cap fasteners to temporarily secure the outer edge of the flashing at the lower corners. (Self tapping Wrap Cap screws are recommended for steel stud framing.) Flashing bond will strengthen over time. When using DuPont™ FlexWrap™ NF, fasteners are not required.

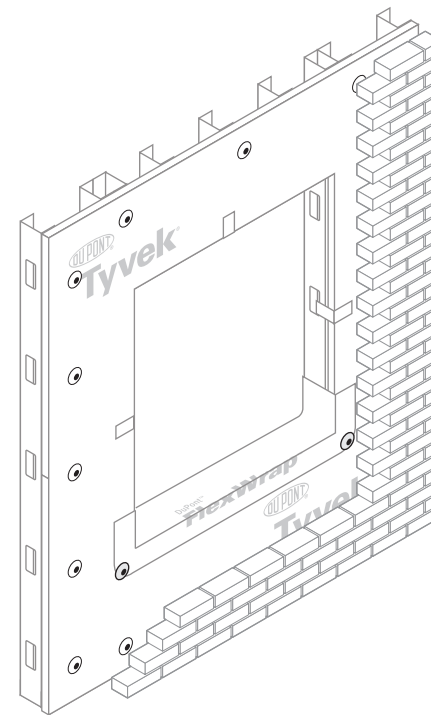

DuPont Flashing Systems Commercial Installation Guidelines

STEP 7

- A. Wrap 9" DuPont™ StraightFlash™ into the rough opening at each jamb and onto wall face. The flashing should align with the interior edge of the jamb framing. Cut the jamb flashing the vertical length of the rough opening.
- B. Jamb flashing should be long enough to overlap the sill flashing by at least 2" and be overlapped by future head flashing by at least 2".

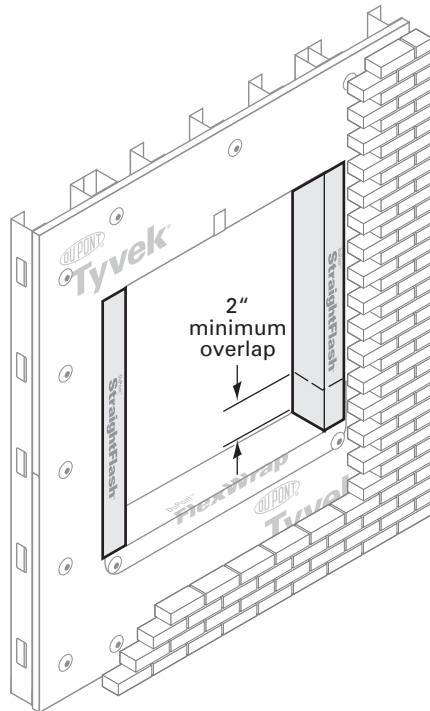

STEP 8

- A. Adhere DuPont™ FlexWrap™ to the head using the same installation process as shown in steps 6 and 7 for the sill flashing. Make sure the DuPont™ FlexWrap™ is cut long enough to overlap the jamb flashing by at least 2 inches.
- B. Use sufficient DuPont™ Tyvek® Wrap Cap fasteners to temporarily secure the outer edge of the flashing at the upper corners. (Self tapping Wrap Cap screws are recommended for steel stud framing.) Flashing bond will strengthen over time. When using DuPont™ FlexWrap™ NF, fasteners are not required.
- C. Optional: For some facades and when specified by the architect, exterior rigid insulation should be added at this time.

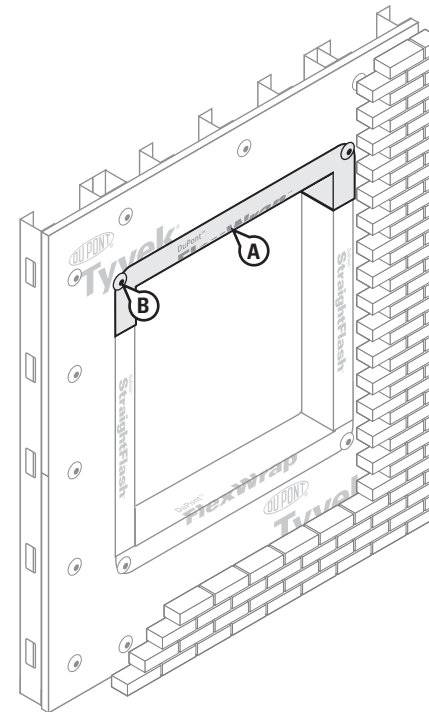

DuPont Flashing Systems Commercial Installation Guidelines

STEP 9.

- A. Cut flap in the DuPont™ Tyvek® weather barrier.
- B. Apply DuPont recommended primer to exposed sheathing.
- C. Install lintel on masonry as required.

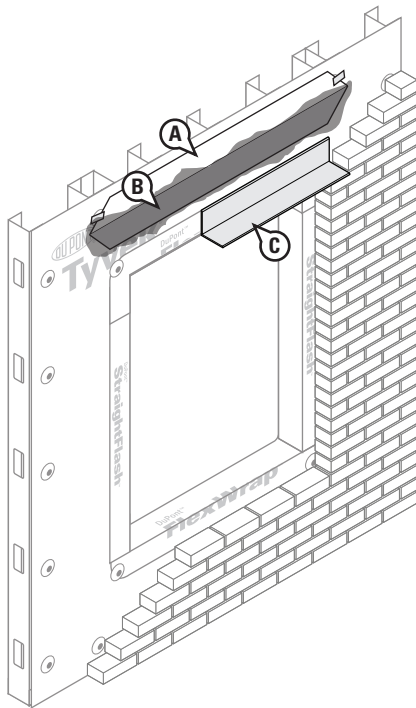

STEP 10

- A. Install corrosion resistant metal pan with drip and soldered/sealed end dams above lintel. Extend flashing beyond the end of lintel.
- B. Install 9" wide strip of DuPont™ StraightFlash™ to bridge between the exterior sheathing and the metal pan flashing. Maintain a minimum of 3" contact between the DuPont™ StraightFlash™ and the primed exposed sheathing surface.
- C. Cut a vertical slit in the DuPont™ StraightFlash™ to accommodate the vertical edge of the metal pan.

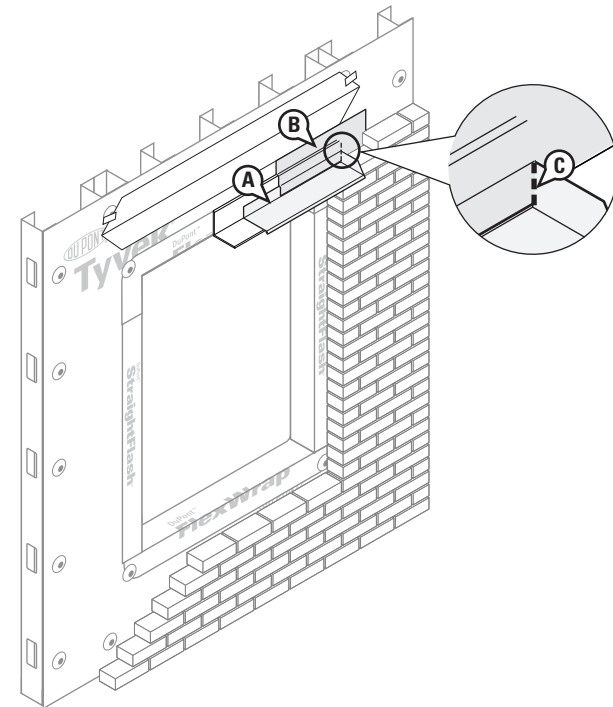

DuPont Flashing Systems Commercial Installation Guidelines

STEP 11

- A. Install an additional layer of either 4" or 9" DuPont™ StraightFlash™ over the first layer of DuPont™ StraightFlash™ if necessary to achieve the 3" minimum contact to the exposed exterior sheathing. The overlap should be a minimum of 1".
- B. Anchor the non-corrosive metal sill pan flashing to the wall and integrate to the DuPont™ Tyvek® weather barrier with 4" DuPont™ StraightFlash™.

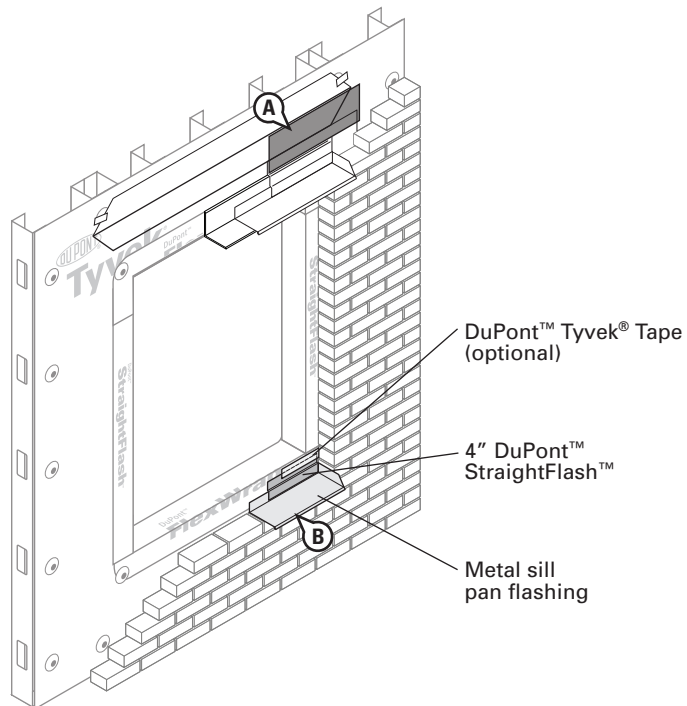

STEP 12

- A. Fold head flap back into place
- B. Tape along bottom edge of cut in DuPont™ Tyvek® weather barrier with DuPont™ StraightFlash™.
- C. Use 4" wide by 16" long pieces of DuPont™ StraightFlash™ at diagonal cut in DuPont™ Tyvek® weather barrier to secure head flap.

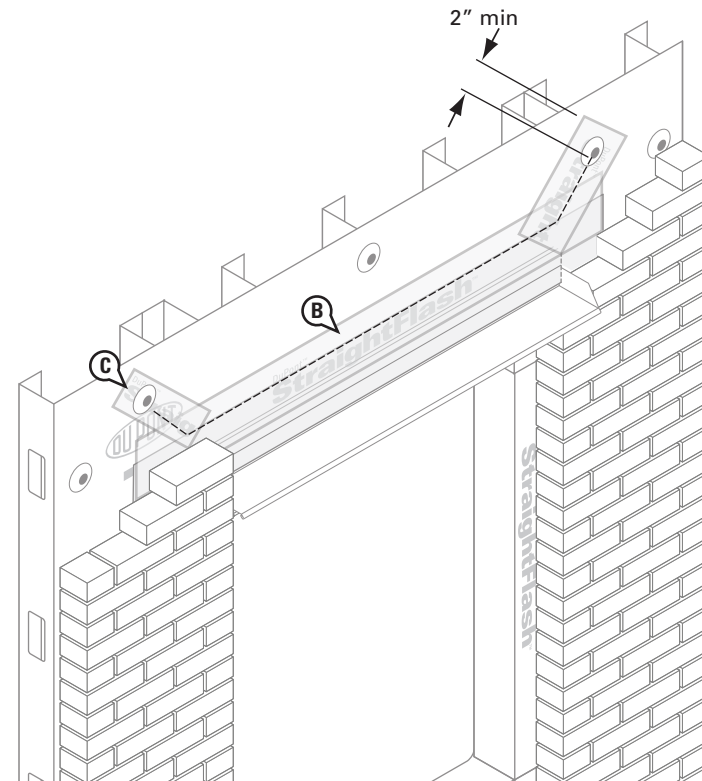

DuPont Flashing Systems Commercial Installation Guidelines

STEP 13

- A. Install remaining masonry with weeps along flashing.
- B. Install window per manufacturer's instructions.
- C. Seal all 4 sides of the perimeter of the window.

DO NOT SEAL ANY WEEPS OF WINDOW FRAME.

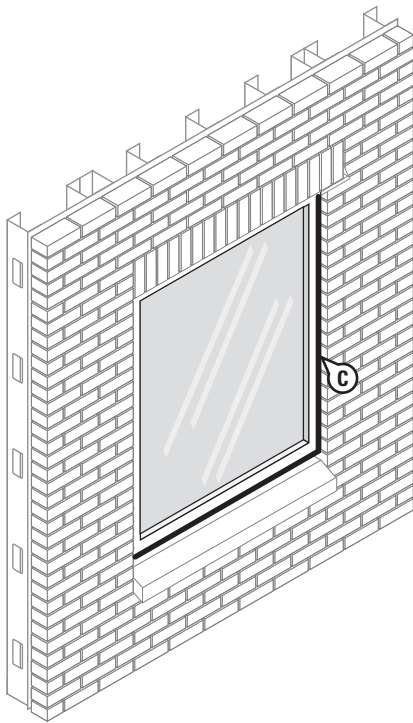

STEP 14

Interior View

- A. Create a continuous perimeter seal with backer rod and DuPont™ Commercial Sealant or recommended sealant on window interior to resist air and water infiltration.

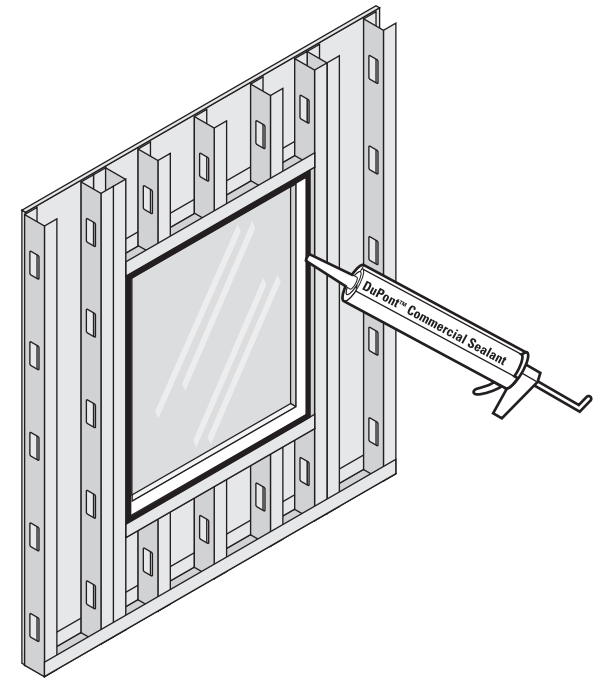

DuPont Flashing Systems Commercial Installation Guidelines

STEP 15

A. While the DuPont™ Commercial Sealant or recommended sealant is still wet, as a best practice, install an “L” shaped back dam cut the width of the rough opening so that it contacts the DuPont™ Commercial Sealant or recommended sealant bead and rear of window. Seal by applying recommended sealant along 4 sides of the exposed back dam. OPTIONAL: DuPont™ Commercial Sealant or recommended sealant along all four sides in lieu of back dam. Note: For alternate back dam see the Brick Mold Installation Guide, steps 2 and 7, later in this document.

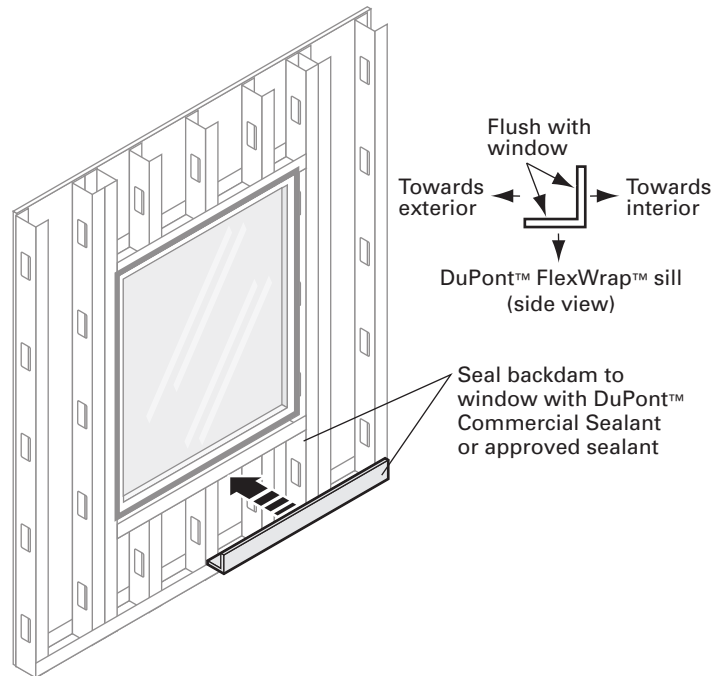

STEP 16

A. Install retention clips around the window to permanently secure it in the rough opening as recommended by window manufacturer to complete installation.

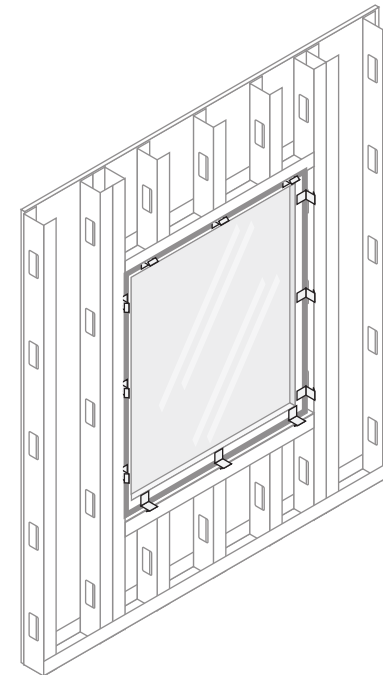

DuPont Flashing Systems Commercial Installation Guidelines

JAMB DETAIL (top view)

Note: For other CAD details visit www.construction.tyvek.com

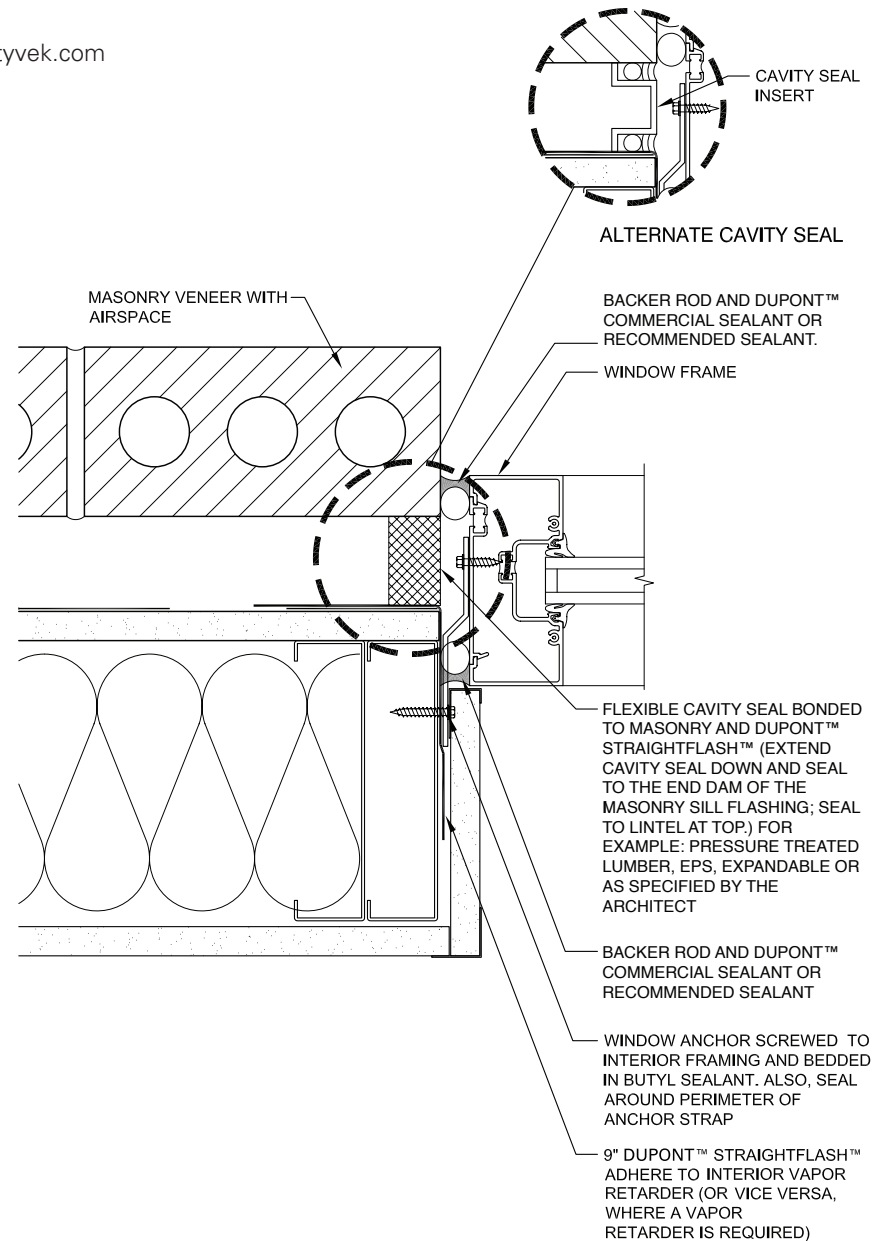

DuPont Flashing Systems Commercial Installation Guidelines

SILL DETAIL (side view) Metal through-wall flashing or DuPont™ Thru-Wall Flashing

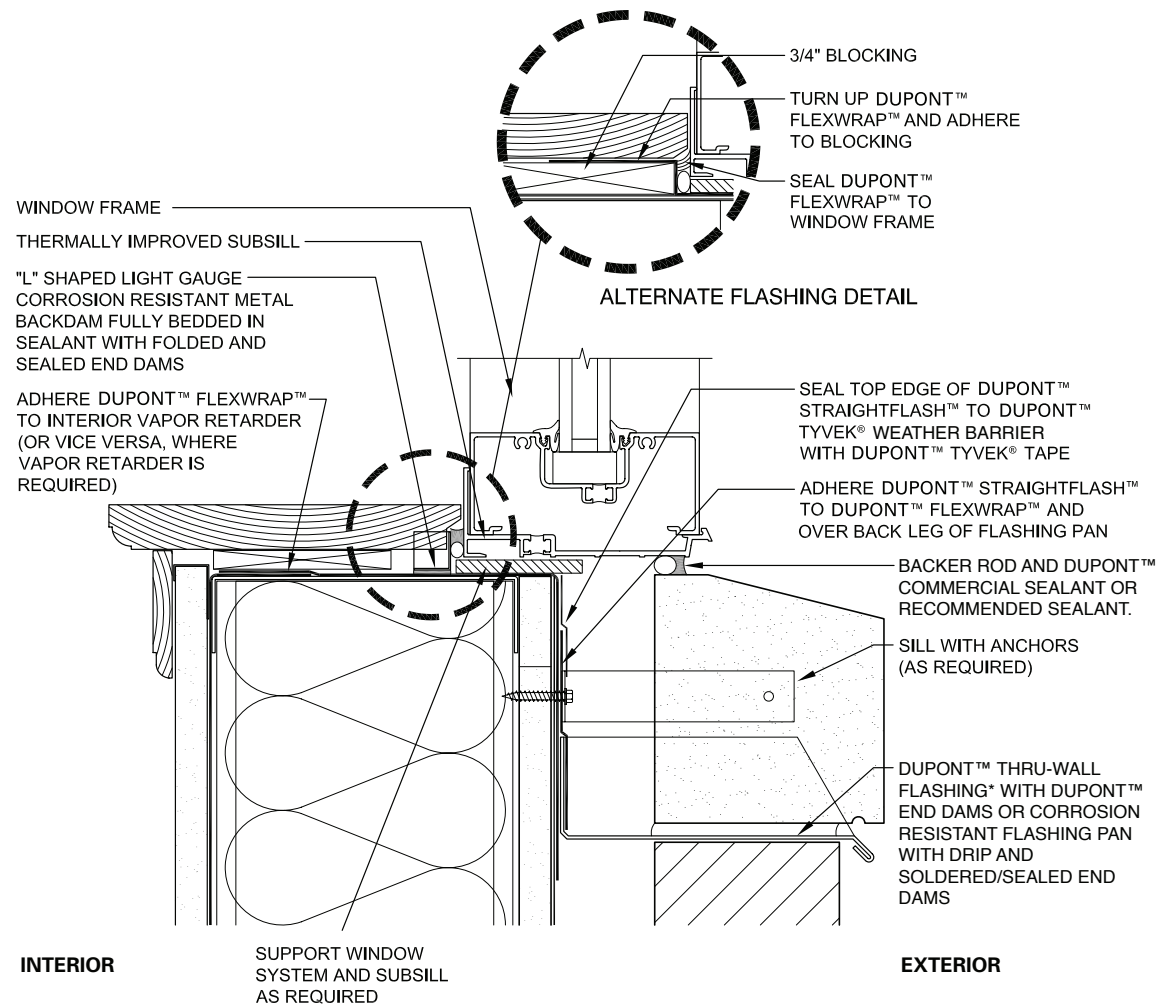

DuPont Flashing Systems Commercial Installation Guidelines

Two through-wall* Flashing Options

Option 1

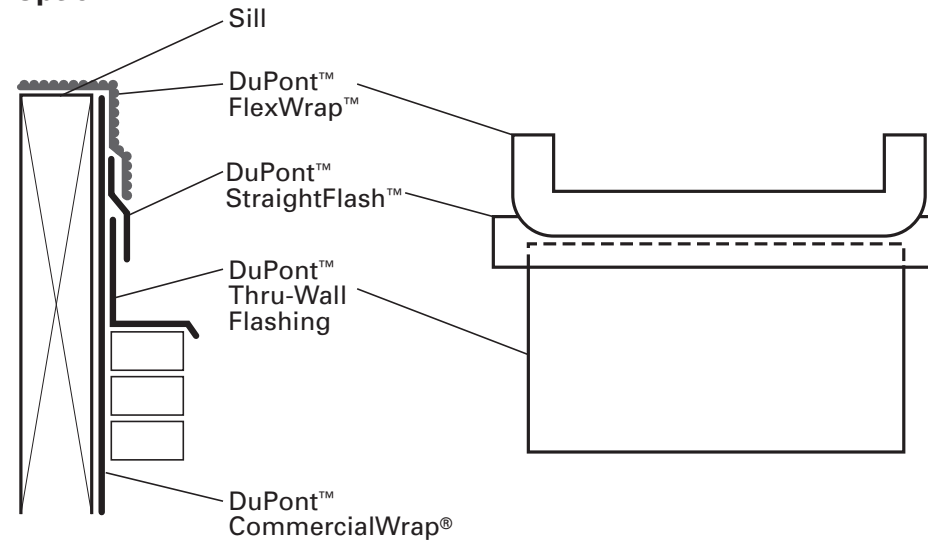

Option 2

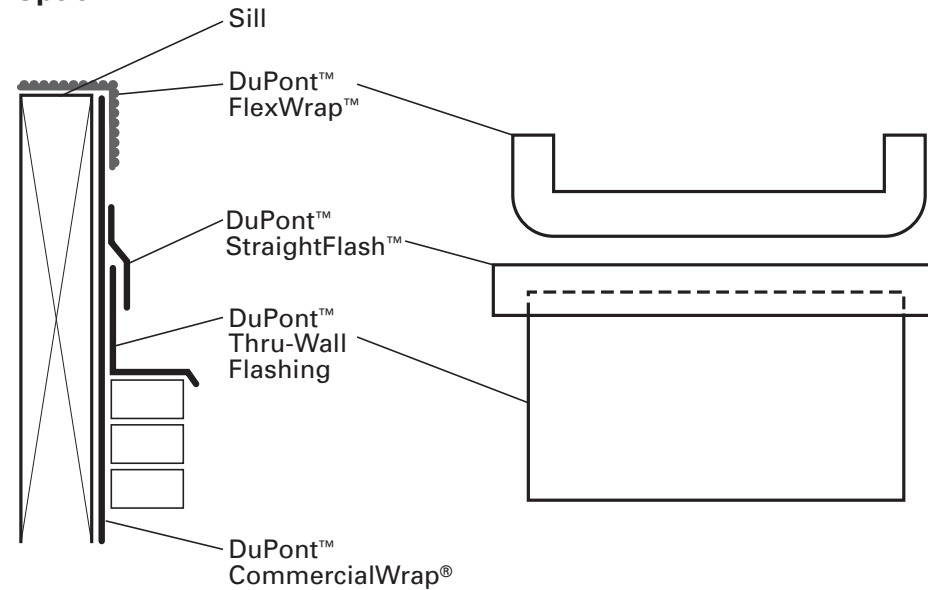

*DuPont™ Thru-Wall Flashing recommended.

DuPont Flashing Systems Commercial Installation Guidelines

HEAD DETAIL (top view) Lintels attached after window flashing

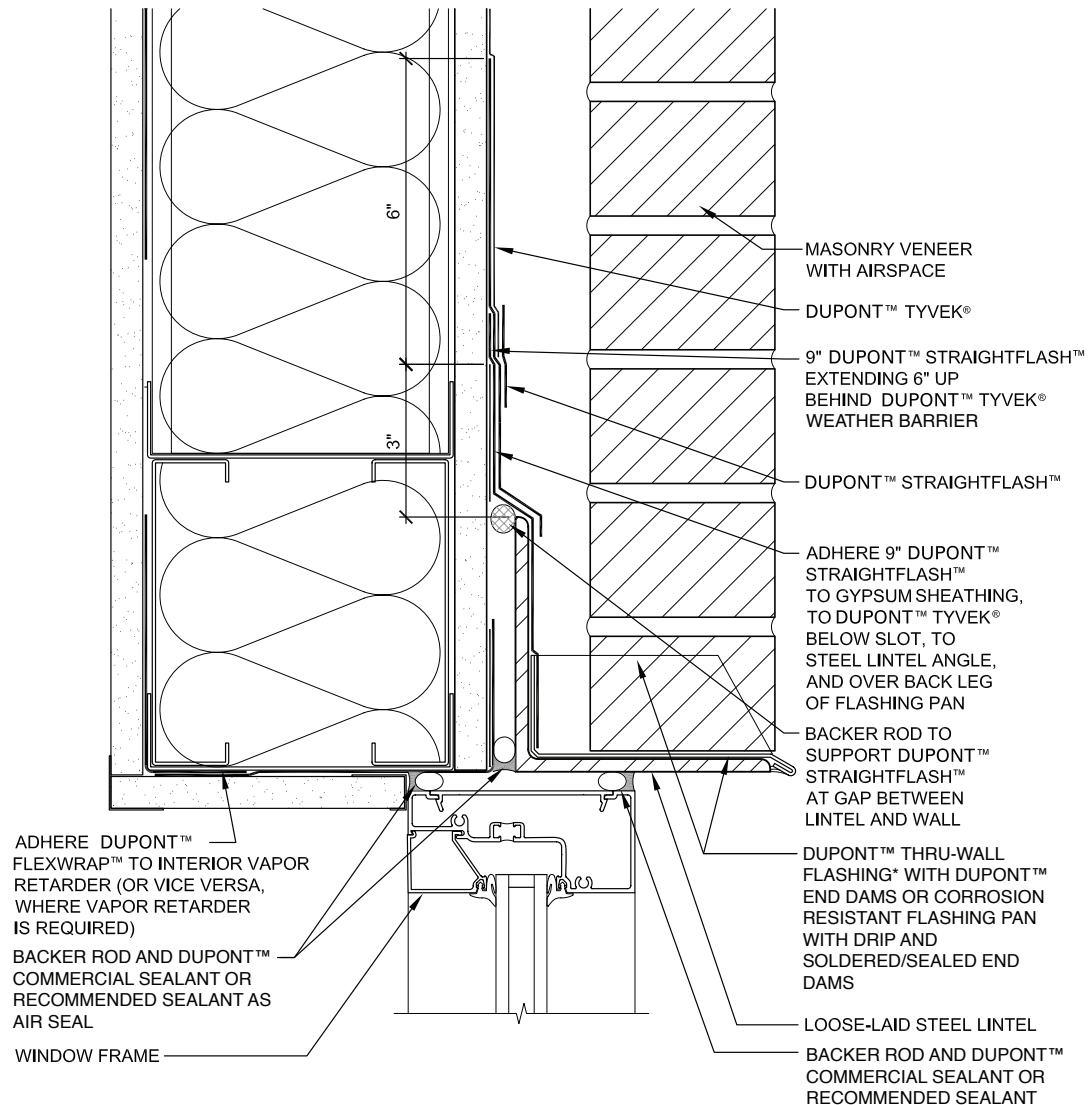

*DuPont™ Thru-Wall Flashing recommended.

DuPont Flashing Systems Commercial Installation Guidelines

Alternate for Lintels attached prior to window flashing

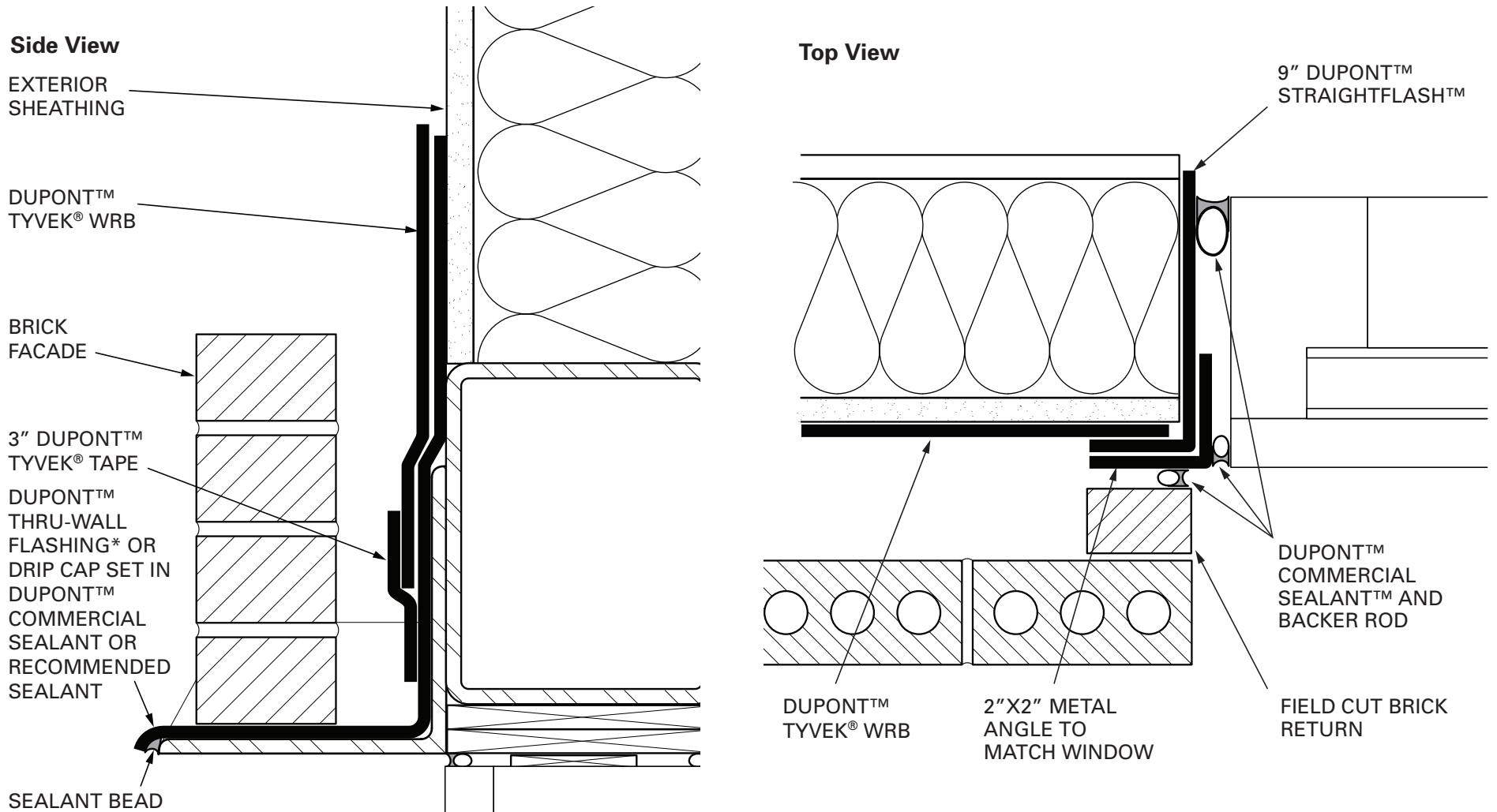

*DuPont™ Thru-Wall Flashing recommended.

DuPont Flashing Systems Commercial Installation Guidelines

Jamb Flashing front view

- A. Cut head.
- B. Flash jamb and sill.
- C. Wrap lintel.
- D. Flash head.
- E. Tape down head flap with 4" DuPont™ Straightflash™.

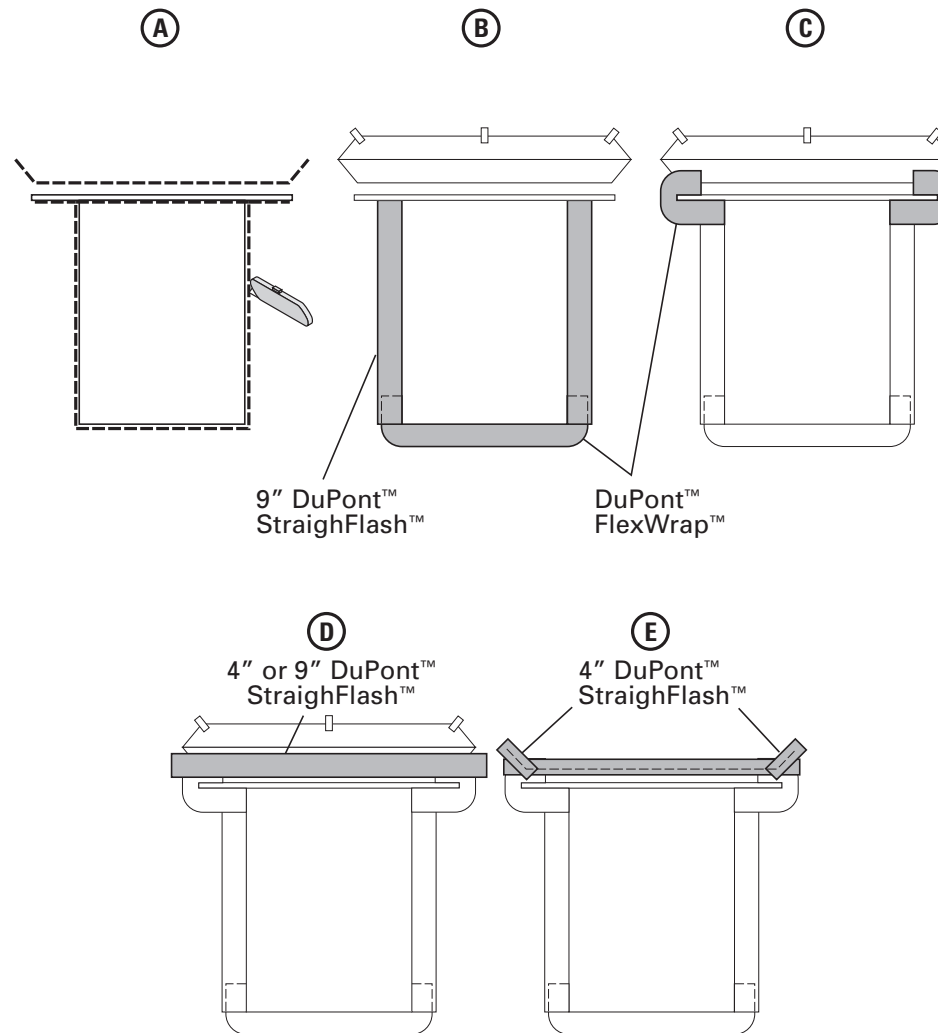

DuPont Flashing Systems Commercial Installation Guidelines

Brick Mold Window

This installation guide can also be used for windows with field applied nailing fins.
Method applies to following products:

DuPont™ StraightFlash™ VF

DuPont™ FlexWrap™

DuPont™ FlexWrap™ NF

STEP 1

Prepare DuPont™ Tyvek® weather barrier for window installation:

- Make an "I-Cut" in the DuPont™ Tyvek® weather barrier (a modified I-Cut is also acceptable). For an "I-Cut" begin with a horizontal cut across the bottom and the top of the window frame (for round top windows, cut from the center cut straight down to the sill).
- Cut two 45° slits a minimum of 8" from the corner of the header to create a flap above the rough opening to expose sheathing or framing members and to allow head flashing installation (see step 5). Flip head flap up and temporarily secure with DuPont™ Tyvek® Tape. Some windows and flashing widths may require longer slits due to window shape.
- Fold side flaps into rough opening, cut excess flaps, and secure.

Note: Side flaps should cover interior facing framing stud.

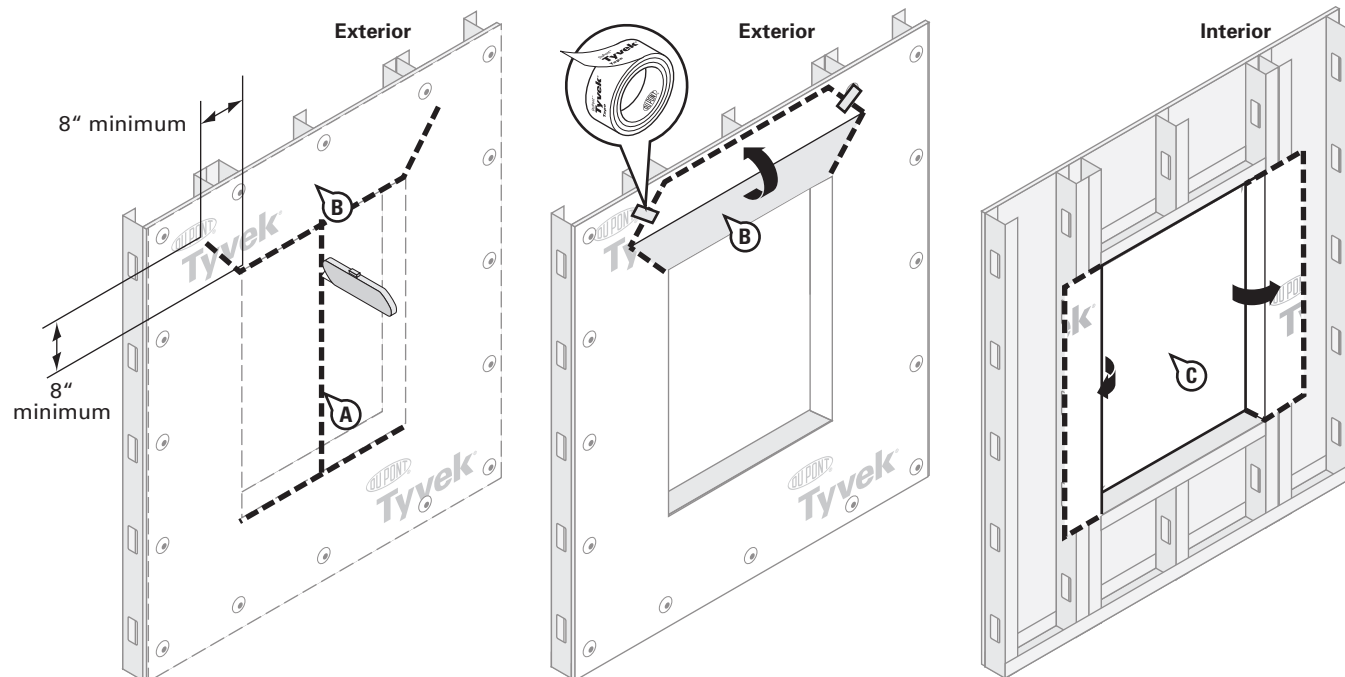

DuPont Flashing Systems Commercial Installation Guidelines

STEP 2

- A. Cut DuPont™ FlexWrap™ at least 12" longer than width of rough opening sill.
- B. Fold to break perforation. Remove center piece of release paper. Cover horizontal sill leaving 1" of overhang on inside edge of sill for back dam, and adhere into rough opening along sill and up jambs (min 6" on each side). Leave 1" overhang of release paper on DuPont™ FlexWrap™ inside rough opening to finish back dam after window installation. When using DuPont™ FlexWrap™ NF, fasteners are not required.
- C. Remove outer release paper.
- D. Flex DuPont™ FlexWrap™ at bottom corners onto face of wall.
- E. Secure edges of DuPont™ FlexWrap™ with sufficient mechanical fasteners (i.e., DuPont™ Tyvek® Wrap Cap nails or screws) along the bottom edge of the DuPont™ FlexWrap™ at flexed corners).

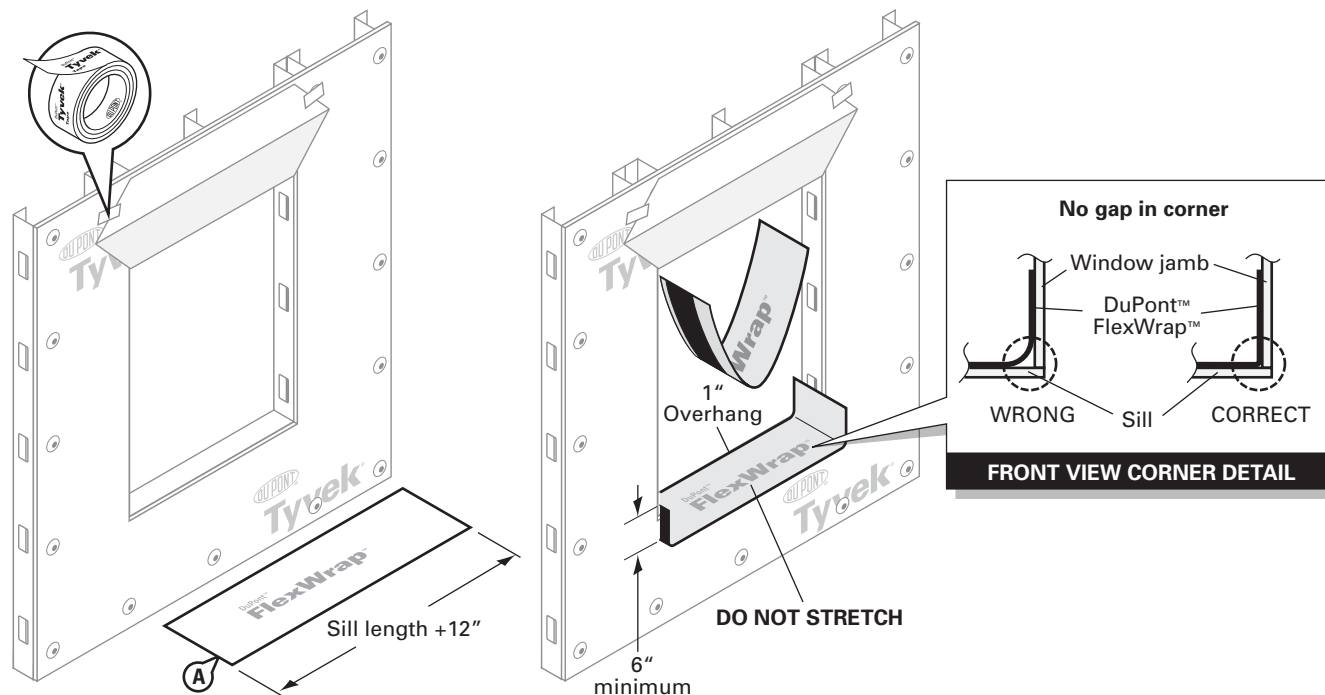

DuPont Flashing Systems Commercial Installation Guidelines

STEP 3

- A. Prepare head flashing by cutting a piece of DuPont™ StraightFlash™ VF at least 12" LONGER than the head length.
- B. Break the scored release paper on one side of the head flashing by folding it back and forth upon itself.
- C. Center the flashing on the window head and position so that it contacts the window frame and interior side of the brick mold. Remove the outer release paper and adhere the flashing to the window frame. Use the inner release paper to form a tight seal in the corner where the brick mold attaches to the window frame.
- D. Remove the inner release paper and adhere the flashing to the back of the brick mold and the window casing.
- E. At the corner of the window frame, cut the DuPont™ StraightFlash™ VF along the corner at a 45° angle.
- F. Fold it down flat against the brick mold.

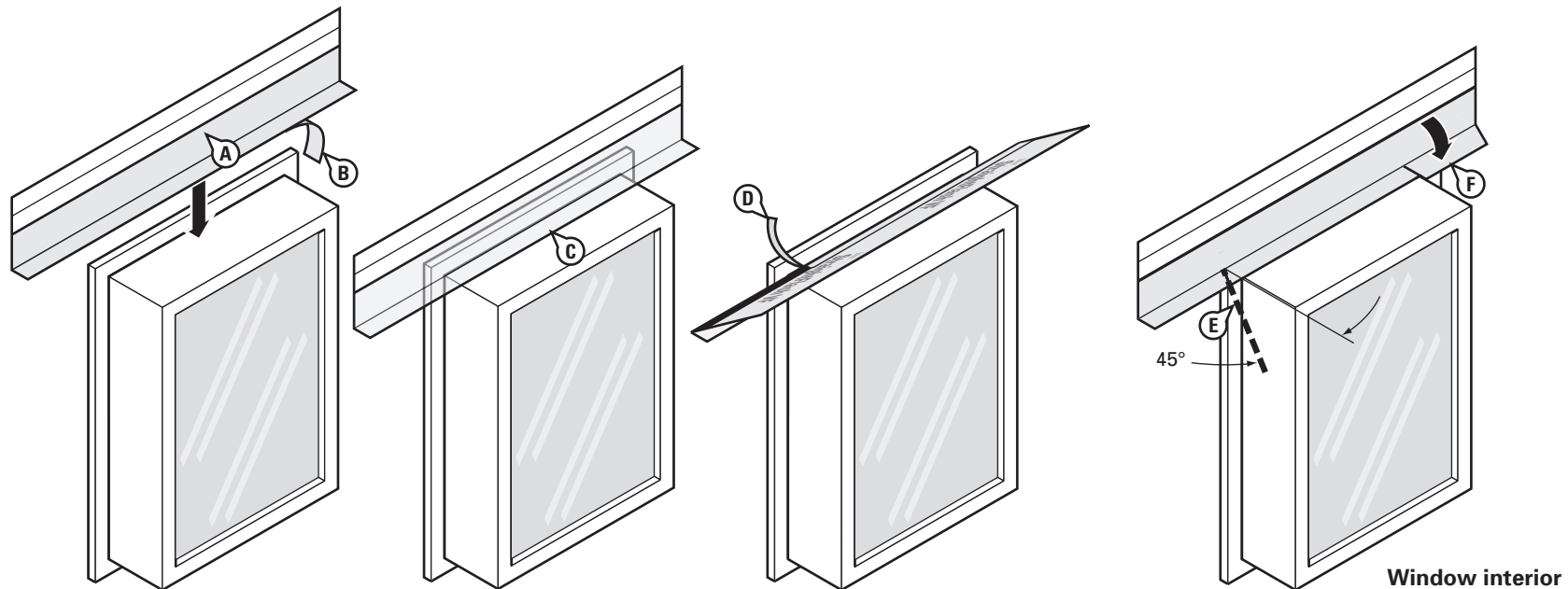
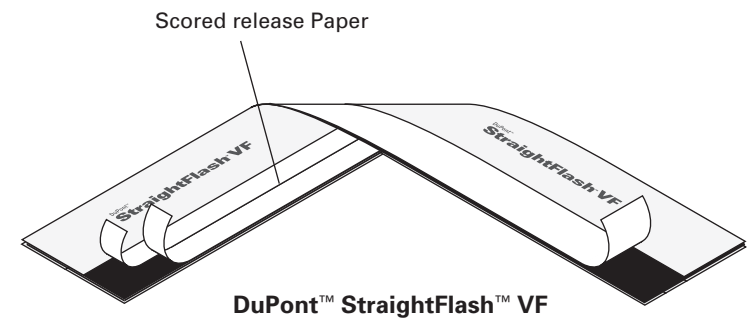

DuPont Flashing Systems Commercial Installation Guidelines

STEP 4

- A. Prepare jamb flashing by cutting a piece of DuPont™ StraightFlash™ VF at least 6" LONGER than the jamb.
- B. Break the scored release paper on one side of the jamb flashing by folding it back and forth upon itself.
- C. Position so that it contacts the window frame and interior side of the brick mold. Ensure that the jamb flashing is positioned 1-1/2" below the top edge of the head flashing. Jamb flashing adhesive must come in contact with head flashing adhesive and overlap by 1".
- D. Remove the outer release paper and adhere the flashing to the window frame. Use the inner release paper to form a tight seal in the corner.
- E. Remove the inner release paper and adhere the flashing to the back of the brick mold.
- F. At the corner of the window frame, cut the DuPont™ StraightFlash™ VF along the corner and fold it down flat to adhere against the head flashing.

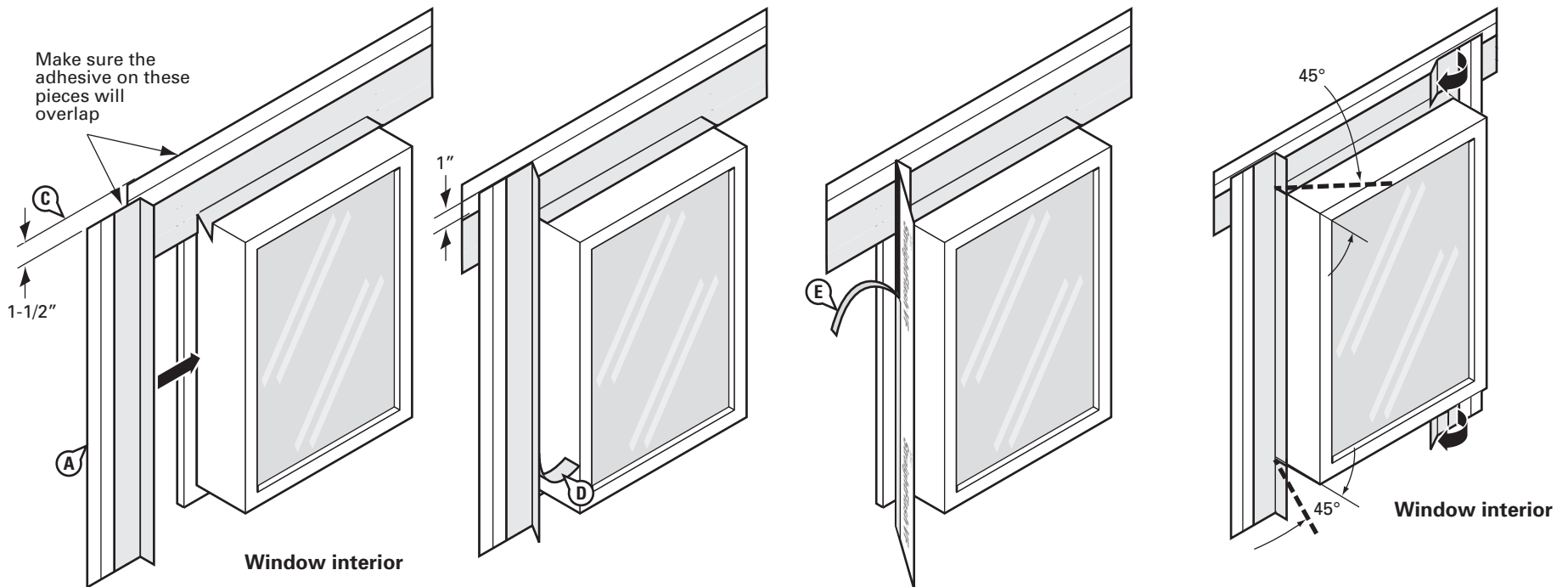

DuPont Flashing Systems Commercial Installation Guidelines

STEP 5

- Install window according to manufacturer's installation instructions.
- Apply DuPont recommended primer to exposed sheathing.
- Remove the remaining release paper from the DuPont™ StraightFlash™ VF jamb flashing and press firmly to adhere it to the DuPont™ Tyvek®.
- Remove the release paper at the head and adhere it to the wall surface.
- Optional: Cover exposed butyl with DuPont™ StraightFlash™ or DuPont™ Tyvek® Tape.

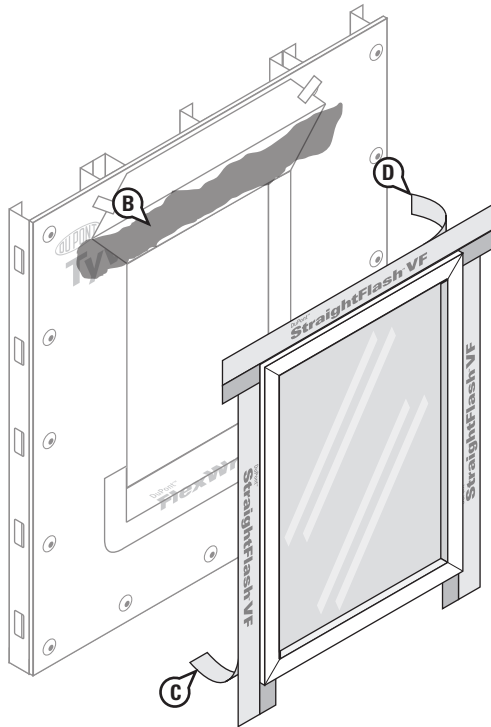

STEP 6

- Cut a piece of metal or vinyl drip cap slightly longer than the window's width and place a bead of DuPont™ Commercial Sealant or recommended sealant on the rear side. Install the drip cap tight against the window head and cover the top edge with DuPont™ StraightFlash™ or DuPont™ Tyvek® Tape.
- Flip down upper flap of DuPont™ Tyvek® weather barrier so it lays flat across head flashing.
- Tape along all cuts in DuPont™ Tyvek® weather barrier and tape across drip cap with 3" DuPont™ Tyvek® Tape or 4" DuPont™ StraightFlash™. (See General Instructions for when 3" DuPont™ Tyvek® Tape is allowed).
- Install DuPont™ Tyvek® Wrap Caps over flashing at recommended spacing.

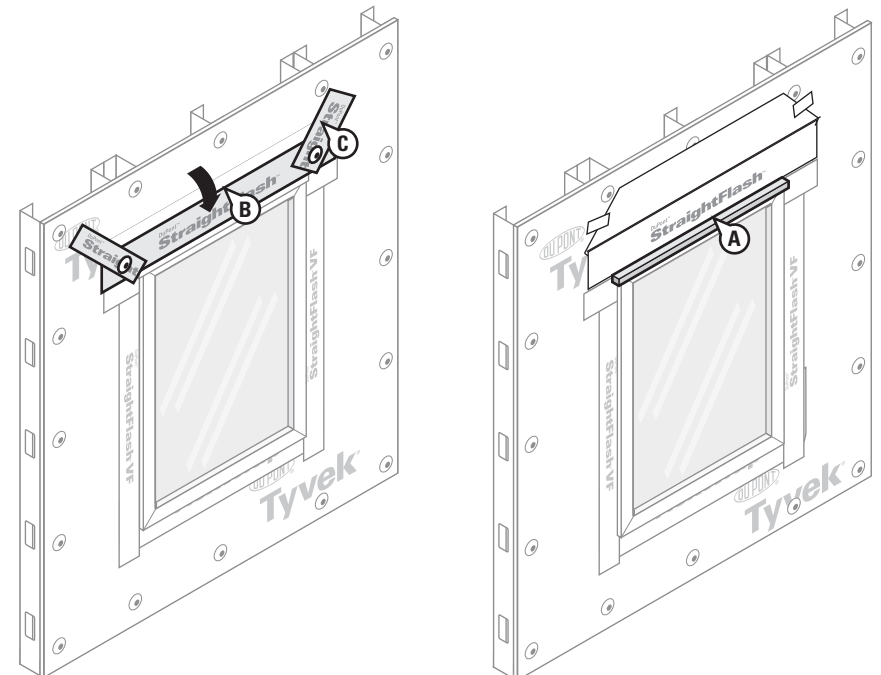
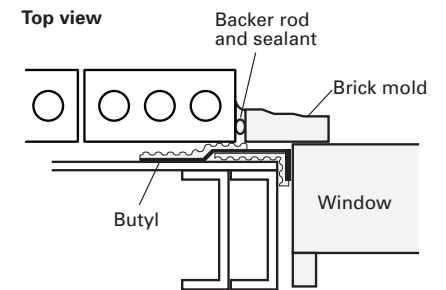

DuPont Flashing Systems Commercial Installation Guidelines

STEP 7

Final Step

- A. Seal around the window opening at the interior, using DuPont™ Commercial Sealant or recommended sealant (and backer rod as necessary). Recommended sealant and backer rod will also serve as a back dam.
- B. If back dam is desired, flip up 1" of DuPont™ FlexWrap™ and fasten corners to stud.

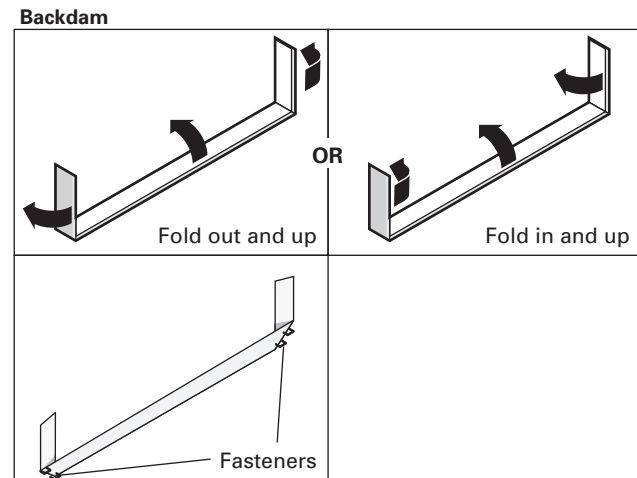
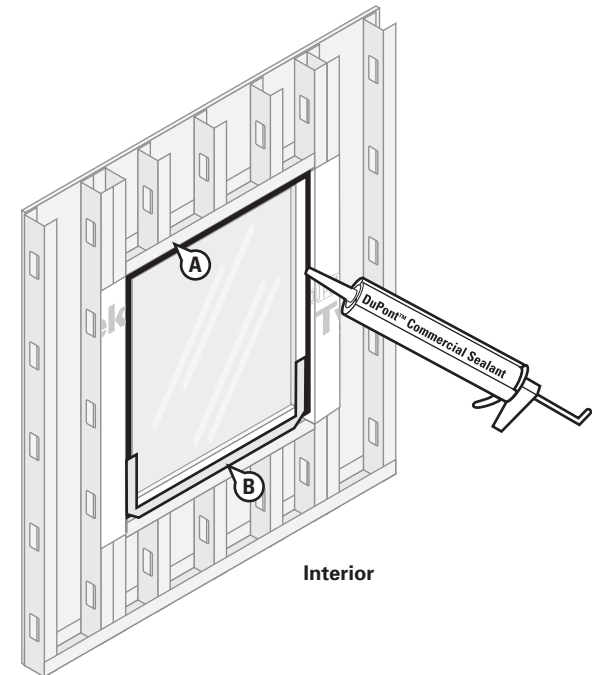

DuPont Flashing Systems Commercial Installation Guidelines

Integral Flanged Aluminum Window

Method applies to following products:

DuPont™ StraightFlash™

DuPont™ FlexWrap™

DuPont™ FlexWrap™ NF

STEP 1

Prepare DuPont™ Tyvek® weather barrier for window installation:

- Make an "I-Cut" in the DuPont™ Tyvek® weather barrier (a modified I-Cut is also acceptable). For an "I-Cut" begin with a horizontal cut across the bottom and the top of the window frame (for round top windows, the cut should begin 2" above the mull joint, see D). From the center cut straight down to the sill.
- Cut two 45 degree slits a minimum of 8" from the corner of the header to create a flap above the rough opening to expose sheathing or framing members and to allow head flashing installation (see step 5). Flip head flap up and temporarily secure with DuPont™ Tyvek® Tape. Some windows and flashing widths may require longer slits.
- Fold side flaps into rough opening, cut excess flaps, and secure.

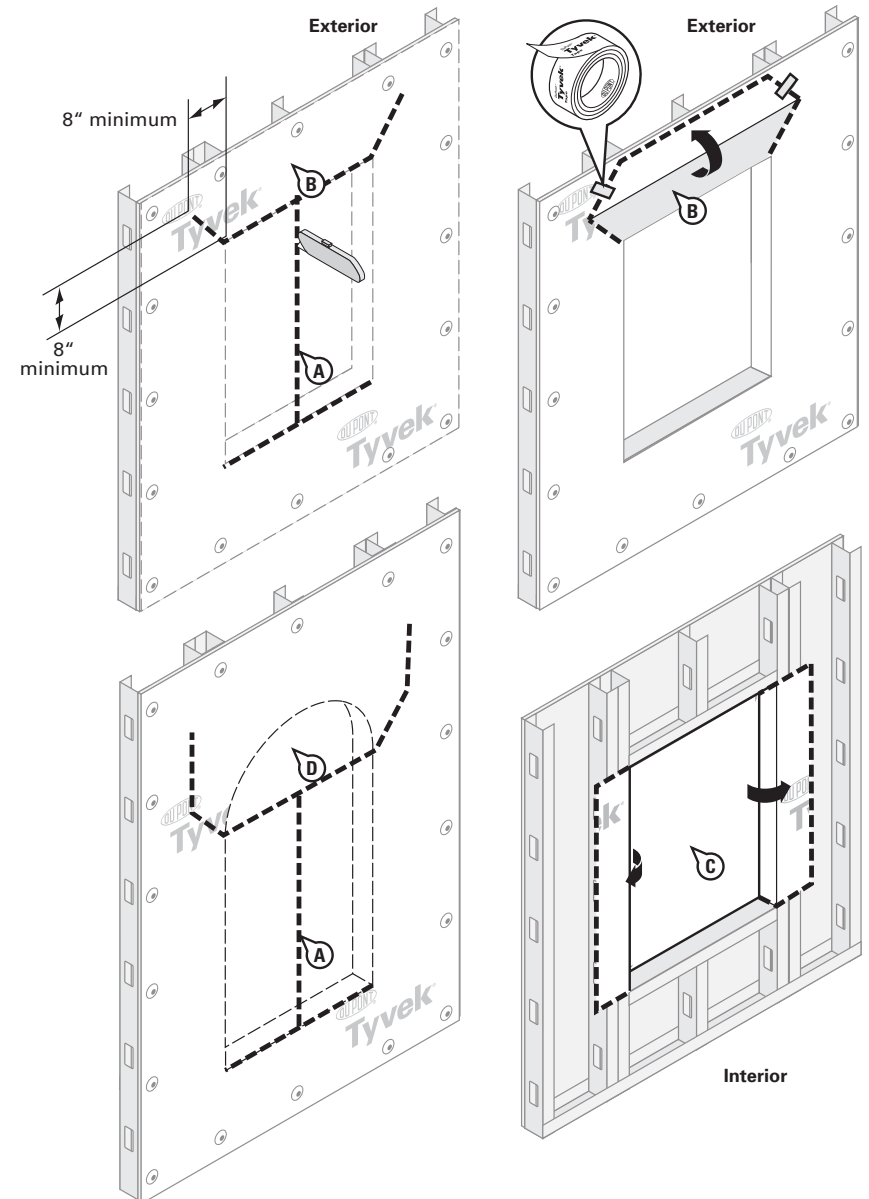

DuPont Flashing Systems Commercial Installation Guidelines

STEP 2

- A. Cut DuPont™ FlexWrap™ at least 12" longer than width of rough opening sill.
- B. Remove the center piece of release paper, cover horizontal sill by overhang inside edge of sill by at least 1" for back dam, and adhere into rough opening along sill and up jambs (min 6" on each side).
- C. Remove second release paper.
- D. Flex DuPont™ FlexWrap™ at bottom corners onto face of wall.
- E. Secure edges of DuPont™ FlexWrap™ with sufficient mechanical fasteners (i.e., DuPont™ Tyvek® Wrap Cap nails, or screws) along the bottom edge of the DuPont™ FlexWrap™ at flexed corners). When using DuPont™ FlexWrap™ NF, fasteners are not required.

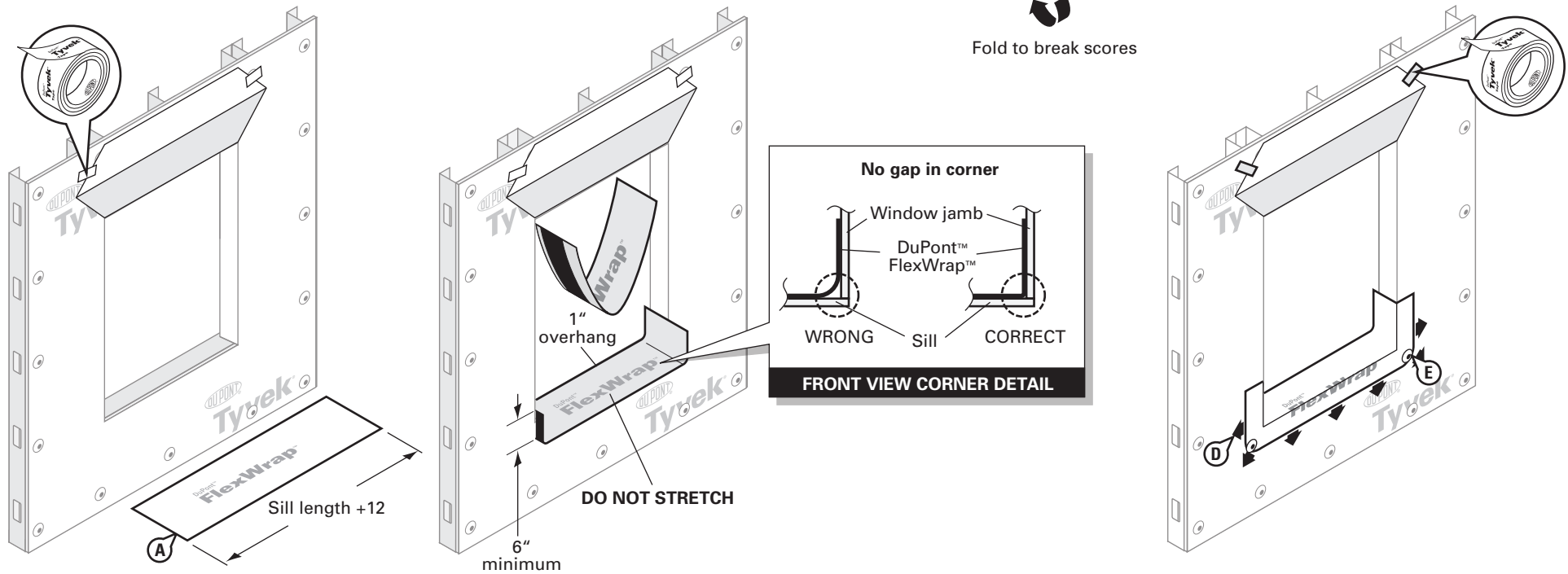

DuPont Flashing Systems Commercial Installation Guidelines

STEP 3

A. Apply continuous bead of DuPont™ Commercial Sealant or recommended sealant at the window head and jamba to wall or back side of window mounting flange.

DO NOT APPLY RECOMMENDED SEALANT ACROSS BOTTOM SILL FLANGE to allow for drainage.

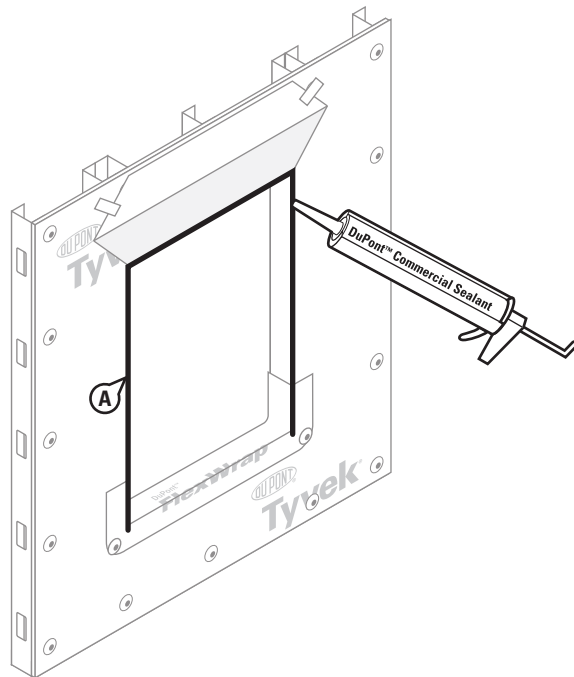

For rectangular windows

STEP 4

A. Install window according to manufacturer's instructions.

B. Apply DuPont recommended primer.

C. Cut two pieces of DuPont™ StraightFlash™ or DuPont™ FlexWrap™ for jamb flashing extending 1" above window head flange and 4" to 6" below bottom edge of sill flashing. Remove release paper and press tightly along sides of window frame.

D. Cut a piece of DuPont™ StraightFlash™ or DuPont™ FlexWrap™ for head flashing, which extends beyond outer edges of jamb flashings. Remove release paper and install completely covering mounting flange and adhering to exposed sheathing or framing members. (See C)

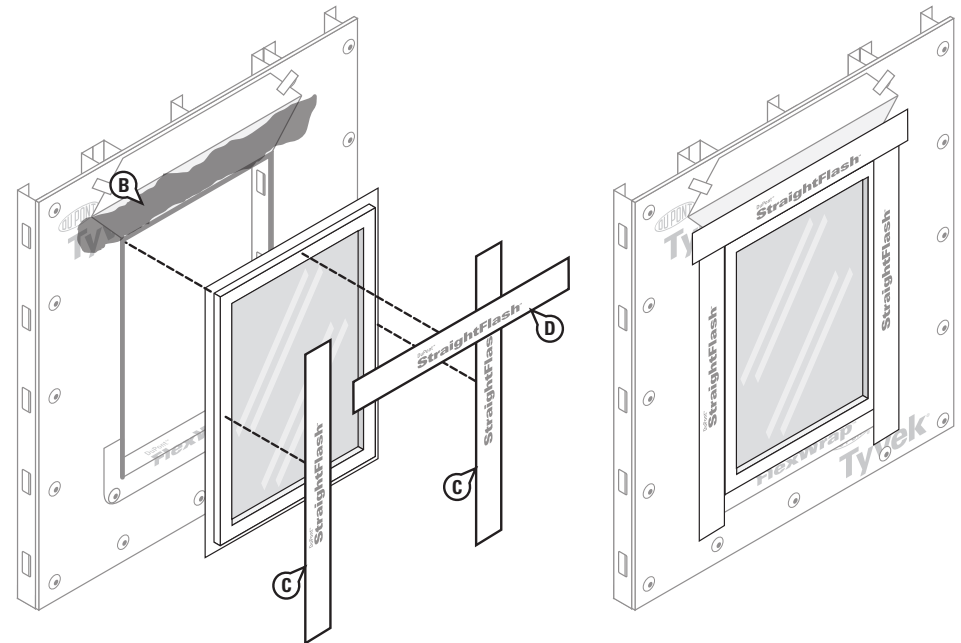

DuPont Flashing Systems Commercial Installation Guidelines

STEP 5

- Flip down upper flap of DuPont™ Tyvek® weather barrier so it lays flat across head flashing.
- Tape along all cuts in DuPont™ Tyvek® weather barrier and tape across head of the window with 3" DuPont™ Tyvek® Tape or 4" DuPont™ StraightFlash™. (See General Instructions for when 3" DuPont™ Tyvek® Tape is allowed.)
- Install DuPont™ Tyvek® Wrap Caps at appropriate spacing at head.

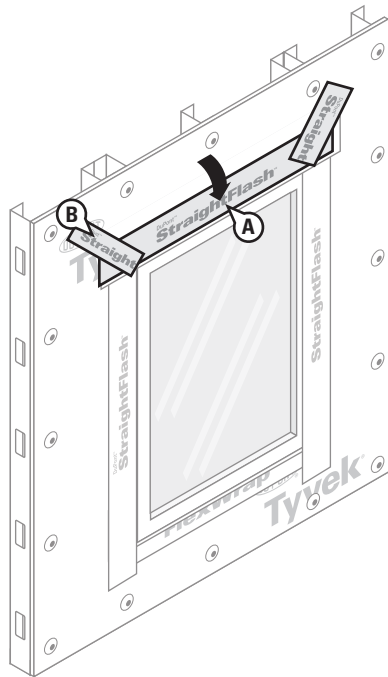

STEP 6

Final Step

- Seal around the window opening at the interior, using DuPont™ Commercial Sealant or recommended sealant (and backer rod as necessary). Recommended sealant and backer rod will also serve as a back dam.
- If back dam is desired, flip up 1" of DuPont™ FlexWrap™ and fasten corners.

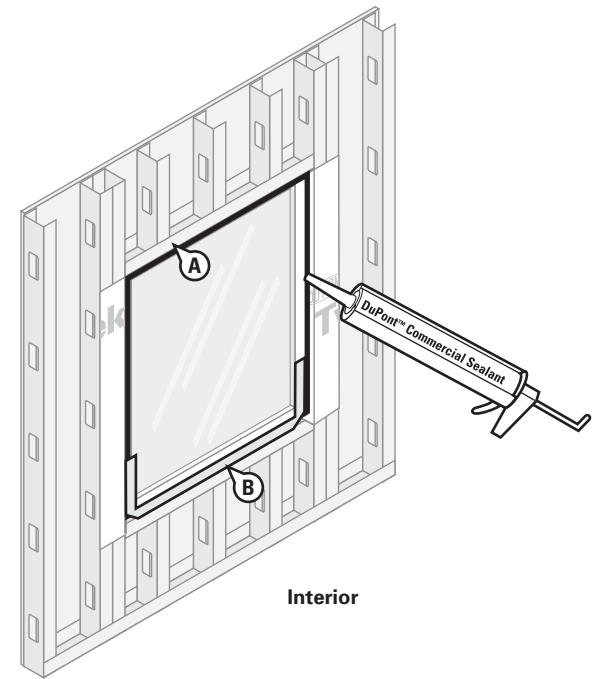

Back dam

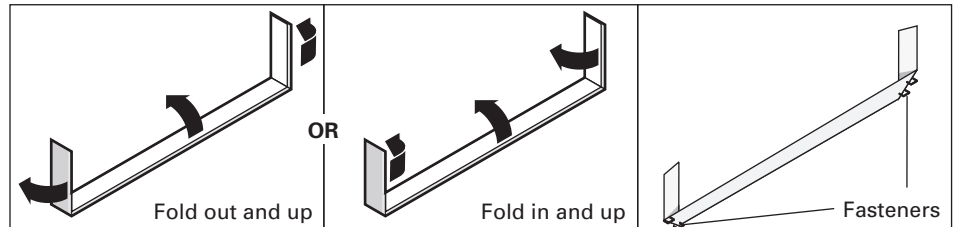

DuPont Flashing Systems Commercial Installation Guidelines

For roundtop windows (integral flange)

STEP 4

- Install window according to manufacturer's instructions.
- Apply the top of the jambs and exposed sheathing with DuPont recommended primer. Cut two pieces of DuPont™ StraightFlash™ or DuPont™ FlexWrap™.
- For jamb flashing extending 1" above window head flange and 4" to 6" below bottom edge of sill flashing. Remove release paper and press tightly along sides of window frame.

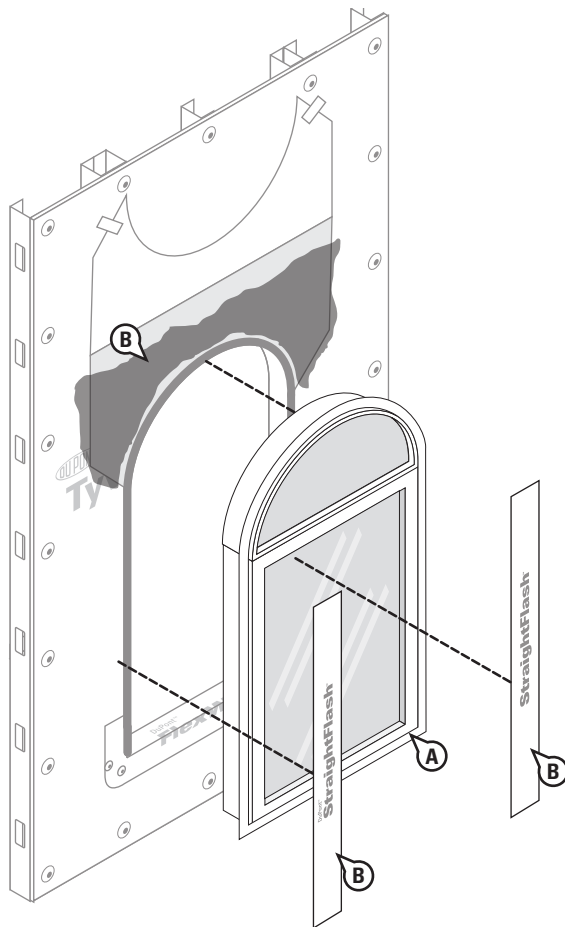

STEP 5

Install head flashing

- Cut head flashing at least 12" longer than the arc length (H) of round-top window.
- Remove both release papers and install to conform around top of window, covering entire mounting flange and adhering to exposed sheathing or framing members. Head flashing should overlap jamb flashings at least 6".
- Secure outer edges of head flashing using mechanical fasteners at studs. e.g. DuPont™ Tyvek® Wrap Caps (nails or screws).

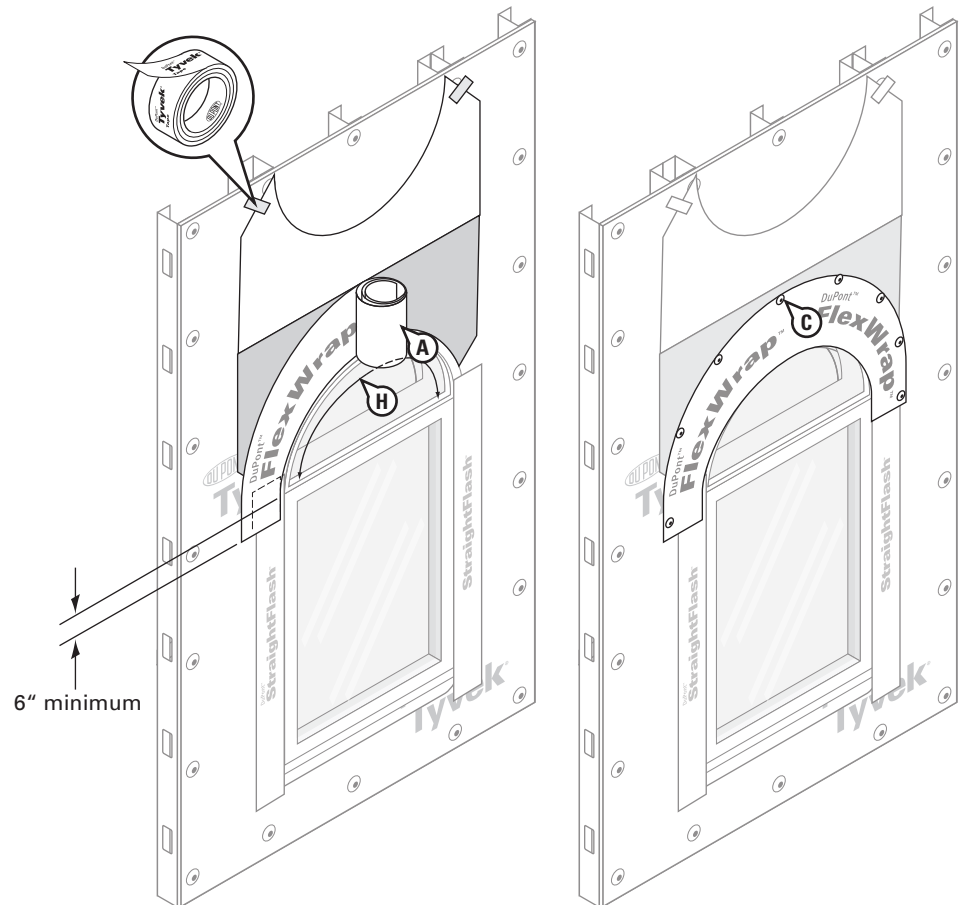

DuPont Flashing Systems Commercial Installation Guidelines

STEP 6

- A. Flip down upper flap of DuPont™ Tyvek® weather barrier so it lays flat across head flashing.
- B. Tape along all cuts in DuPont™ Tyvek® weather barrier and across head of the window with 3" DuPont™ Tyvek® Tape or 4" DuPont™ StraightFlash™. (See General Instructions for when 3" DuPont™ Tyvek® Tape is allowed.)

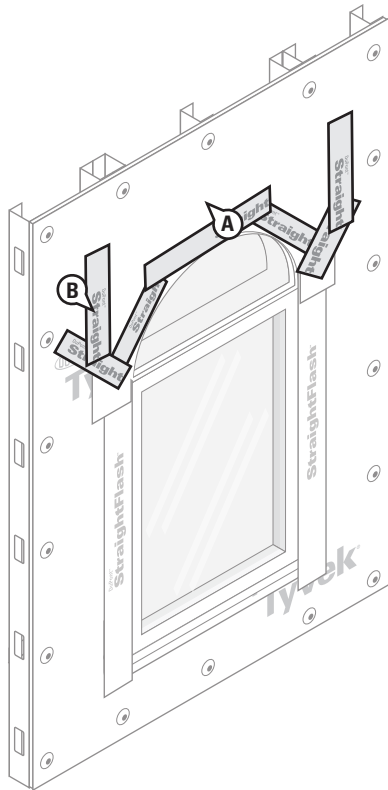

STEP 7

Final Step

- A. Seal around the window opening at the interior, using DuPont™ Commercial Sealant or recommended sealant (and backer rod as necessary). Recommended sealant and backer rod will also serve as a back dam.
- B. If back dam is desired, flip up 1" of DuPont™ FlexWrap™ and fasten corners.

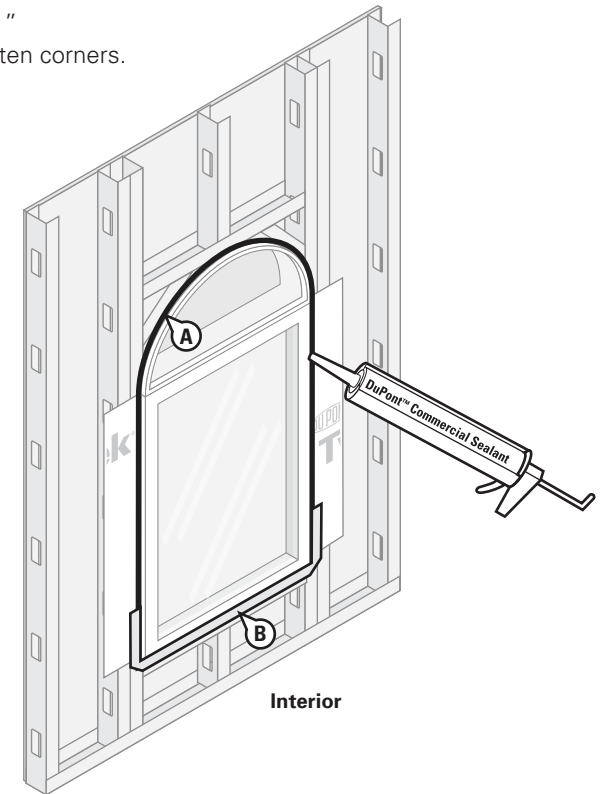

Back dam

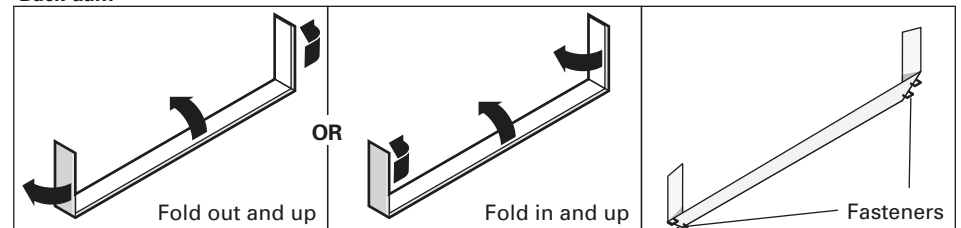

DuPont Flashing Systems Commercial Installation Guidelines

Non-Flanged Aluminum Window using DuPont™ StraightFlash™ VF

Method applies to following products:

DuPont™ StraightFlash™ VF

DuPont™ FlexWrap™

DuPont™ FlexWrap™ NF

STEP 1

Prepare DuPont™ Tyvek® weather barrier for window installation:

A. Make an "I-Cut" in the DuPont™ Tyvek® weather barrier (a modified I-Cut is also acceptable). For an "I-Cut" begin with a horizontal cut across the bottom and the top of the window frame. From the center cut straight down to the sill.

B. Cut two 45° slits a minimum of 8" from the corner of the header to create a flap above the rough opening to expose sheathing or framing members and to allow head flashing installation (see step 5). Flip head flap up and temporarily secure with DuPont™ Tyvek® Tape. Some windows and flashing widths may require longer slits.

C. Fold side flaps into rough opening, cut excess flaps, and secure.

Note: Side flaps should cover interior facing framing stud.

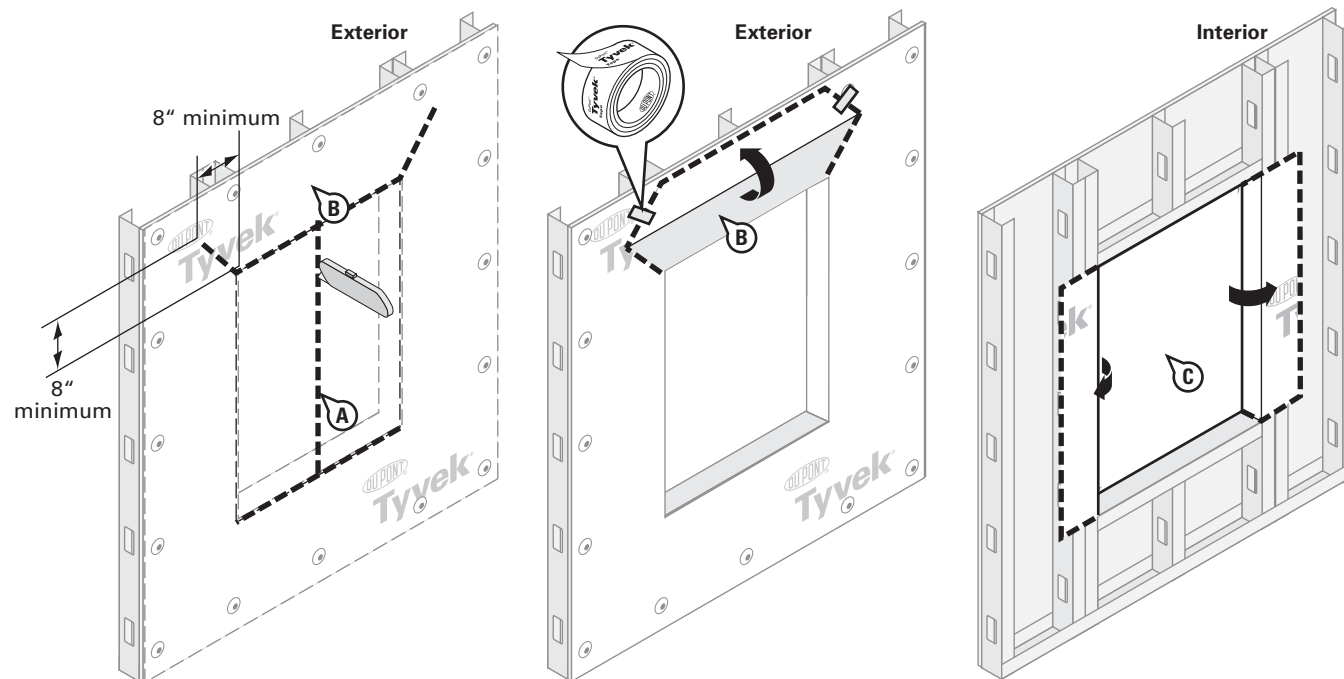

DuPont Flashing Systems Commercial Installation Guidelines

STEP 2

- A. Cut DuPont™ FlexWrap™ at least 12" longer than width of rough opening sill.
- B. Remove the center piece of release paper, cover horizontal sill by overhang inside edge of sill by at least 1" for back dam, and adhere into rough opening along sill and up jambs (min 6" on each side).
- C. Remove second release paper.
- D. Flex DuPont™ FlexWrap™ at bottom corners onto face of wall.
- E. Secure edges of DuPont™ FlexWrap™ with sufficient mechanical fasteners (i.e., DuPont™ Tyvek® Wrap Cap nails, or screws) along the bottom edge of the DuPont™ FlexWrap™ at flexed corners. When using DuPont™ FlexWrap™ NF, fasteners are not required.

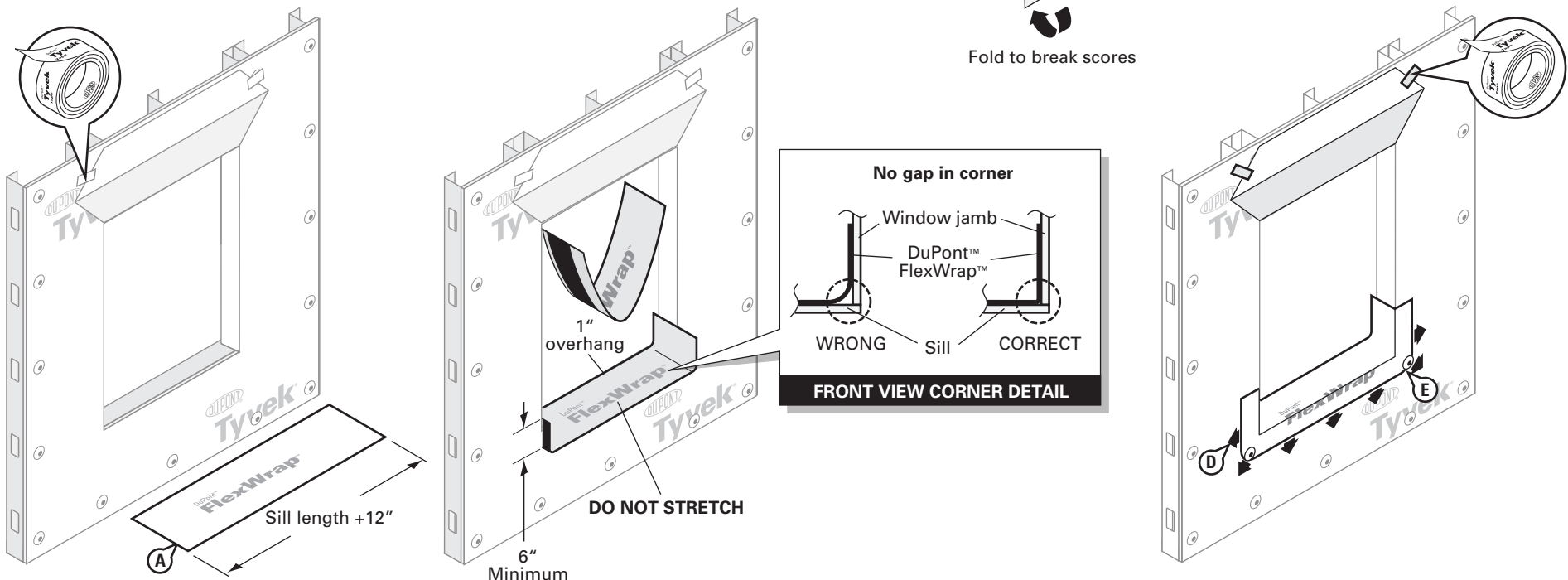
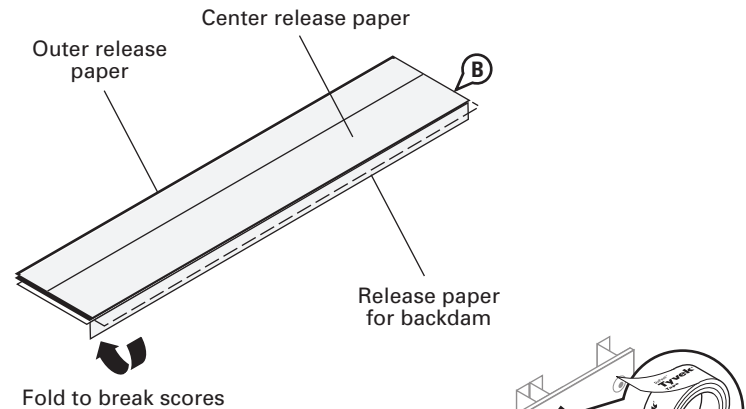

DuPont Flashing Systems Commercial Installation Guidelines

STEP 3

- A. Prepare head flashing by cutting a piece of DuPont™ StraightFlash™ VF at least 12" LONGER than the head length. Before flashing, prime window fins and casings with recommended primer.
- B. Break the scored release paper on one side of the head flashing by folding it back and forth upon itself.
- C. Center the flashing on the window head and position so that it contacts the window frame and interior side of the front flange. Remove the outer release paper and adhere the flashing to the window frame. Use the inner release paper to form a tight seal in the corner.
- D. Remove the inner release paper and adhere the flashing to the back of the aluminum window fin and casing.
- E. At the corner of the window frame, cut the DuPont™ StraightFlash™ VF along the corner at a 45° angle.
- F. Fold it down flat.

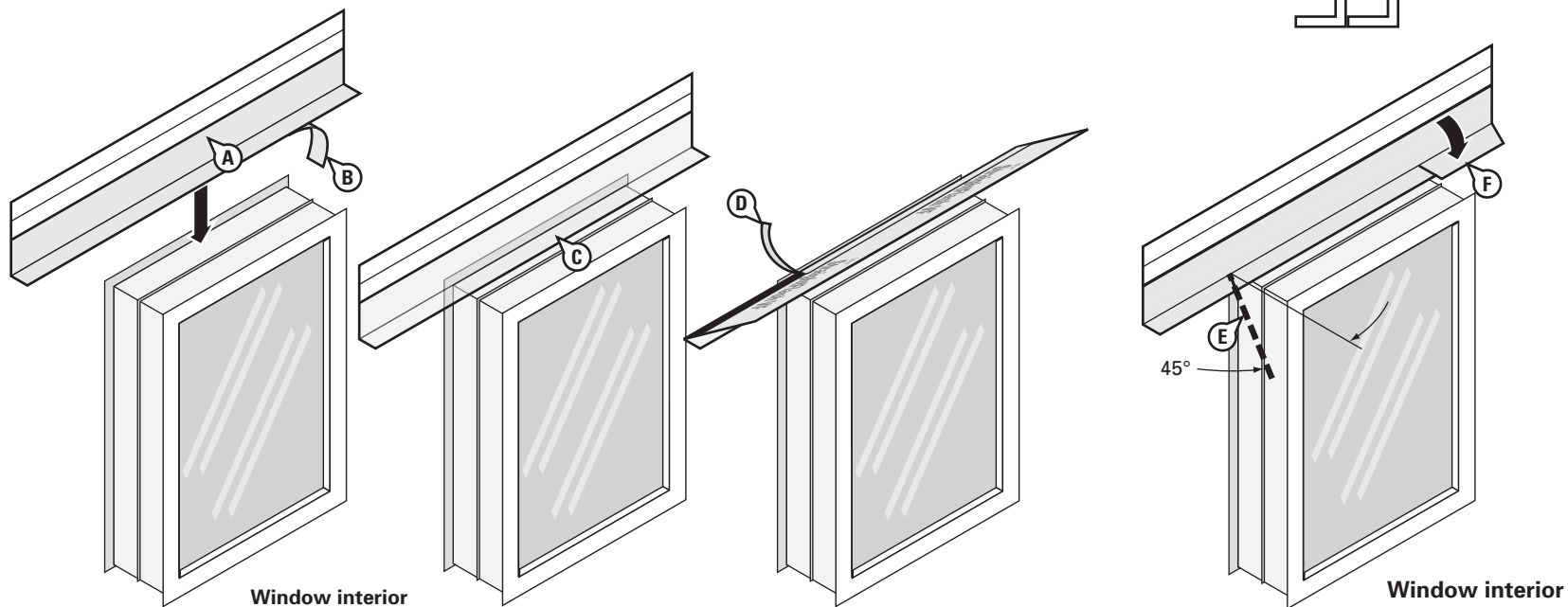
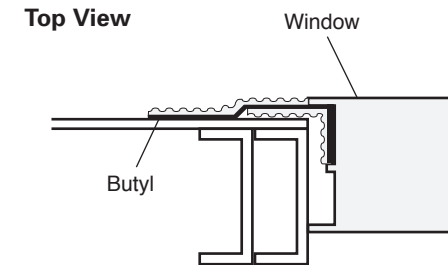
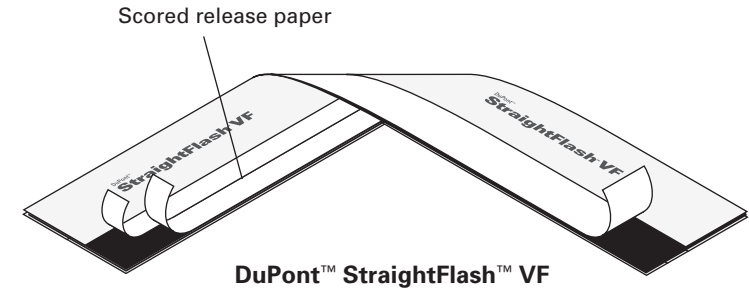

DuPont Flashing Systems Commercial Installation Guidelines

STEP 4

- A. Prepare jamb flashing by cutting a piece of DuPont™ StraightFlash™ VF at least 6" LONGER than the jamb.
- B. Break the scored release paper on one side of the jamb flashing by folding it back and forth upon itself.
- C. Position the flashing so that it contacts the window frame and interior side of the aluminum window fin. Ensure that the jamb flashing is positioned 1-1/2 inch below the top edge of the head flashing. Jamb flashing adhesive must come in contact with head flashing adhesive and overlap by 1".
- D. Remove the outer release paper and adhere the flashing to the window frame. Use the inner release paper to form a tight seal in the corner.
- E. Remove the inner release paper and adhere the flashing to the back of the aluminum window fin.
- F. At the corner of the window frame, cut the DuPont™ StraightFlash™ VF along the corner and fold it down flat to adhere against the head flashing.
- G. Cut a 2" x 4" piece of DuPont™ FlexWrap™ or DuPont™ FlexWrap™ NF and patch each corner.

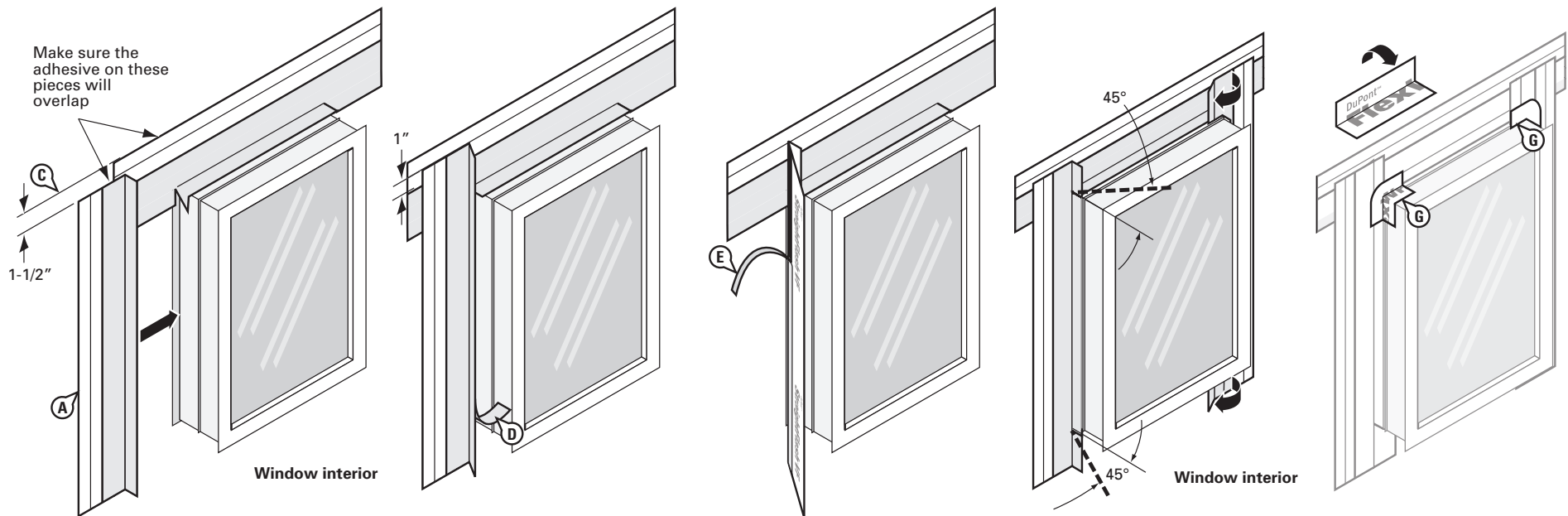

DuPont Flashing Systems Commercial Installation Guidelines

STEP 5

- Install window according to manufacturer's installation instructions.
- Apply DuPont recommended primer to the top of the jambs and exposed sheathing.
- Remove the remaining release paper from the DuPont™ StraightFlash™ VF jamb flashing and press firmly to adhere it to the DuPont™ Tyvek® weather barrier.
- Remove the release paper at the head and adhere it to the wall surface.
- Optional: Cover exposed butyl with DuPont™ StraightFlash™ or DuPont™ Tyvek® Tape.

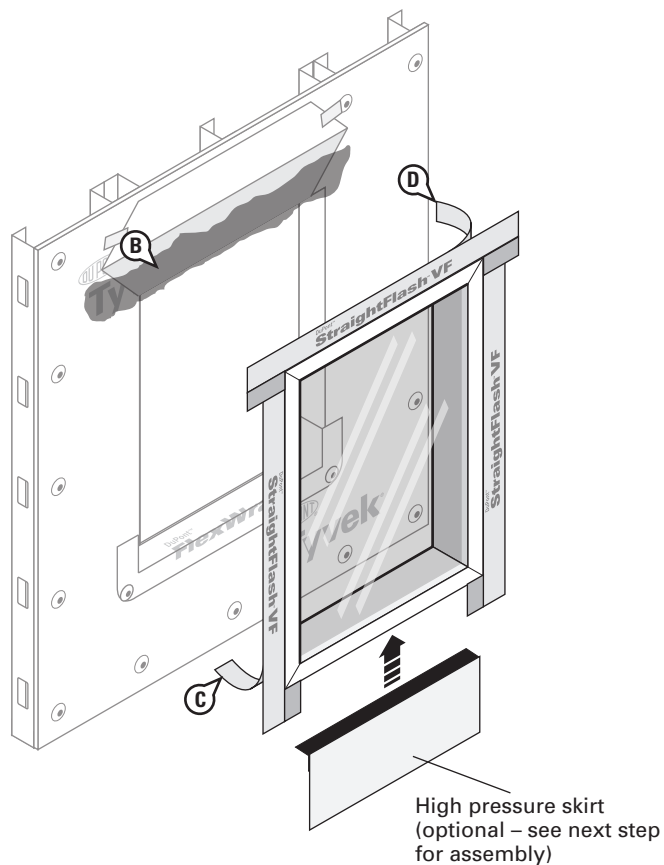

STEP 5 – OPTIONAL

Where buildings could be exposed to extreme weather conditions (ie. sustained wind driven rain above 50mph). For best practice DuPont recommends to install a high pressure skirt to prevent water intrusion at the sill. Attach the high pressure skirt to the underside of the window prior to installing the window in opening.

- Create the high pressure skirt by cutting a piece of DuPont™ Tyvek® weather barrier 1" wider than the width of window opening and approximately 10" in depth.
- Attach skirt to underside of window using a piece of 4" DuPont™ StraightFlash™ cut to the same width as the skirt.

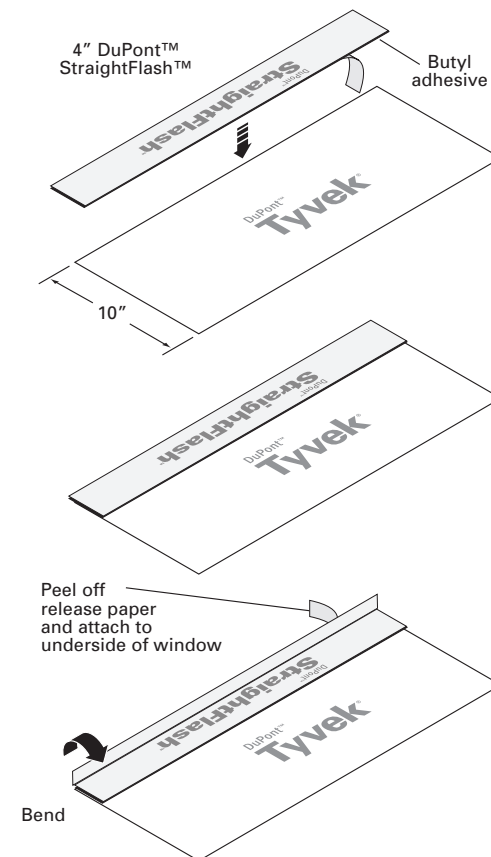

DuPont Flashing Systems Commercial Installation Guidelines

STEP 6

- A. Cut a piece of metal or vinyl drip cap slightly longer than the window's width and place a bead of recommended sealant on the rear side. Install the drip cap tight against the window head and cover the top edge with DuPont™ StraightFlash™ or DuPont™ Tyvek® Tape.
- B. Flip down upper flap of DuPont™ Tyvek® weather barrier so it lays flat across head flashing.
- C. Tape along all cuts in DuPont™ Tyvek® weather barrier and tape across drip cap with DuPont™ Tyvek® Tape or 4" DuPont™ StraightFlash™.
- D. Install DuPont™ Tyvek® Wrap Caps at jambs, skirt and head flap at recommended spacing.

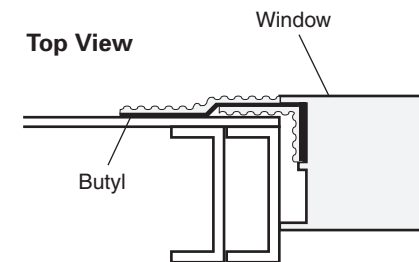
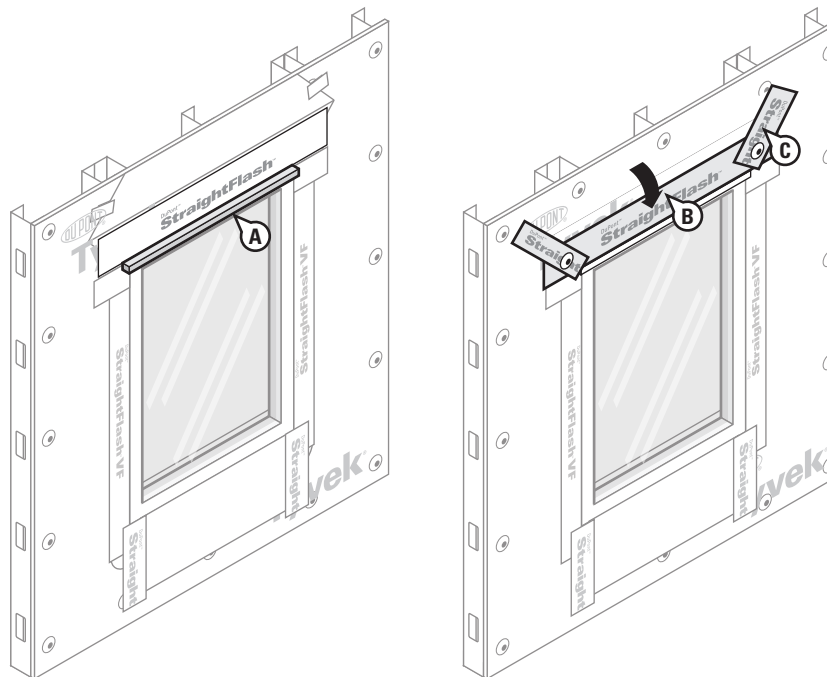

DuPont Flashing Systems Commercial Installation Guidelines

STEP 7

- A. Secure DuPont™ StraightFlash™ VF with DuPont™ Tyvek® Wrap Caps or recommended fasteners.
- B. Install DuPont™ Wrap Caps through the skirt.
- C. Secure sides of high pressure skirt to weather barrier with DuPont™ StraightFlash™ and skip tape bottom with DuPont™ Tyvek® Tape or 4" DuPont™ StraightFlash™. Skip taping provides weeps that allows drainage behind the skirt.

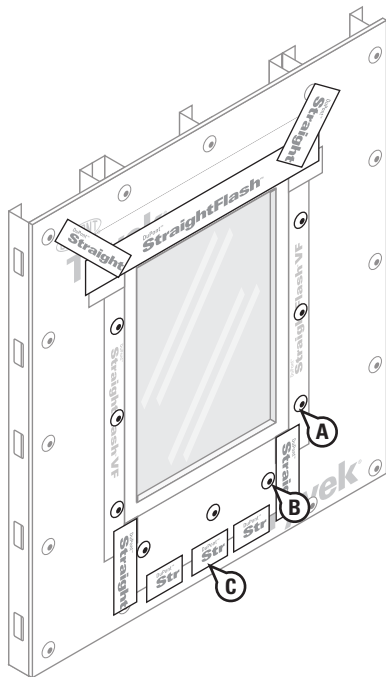

STEP 8

Final Step

- A. Seal around the window opening at the interior, using DuPont™ Commercial Sealant or recommended sealant (and backer rod as necessary). Recommended sealant and backer rod will also serve as a back dam.
- B. If back dam is desired, flip up 1" of DuPont™ FlexWrap™ and fasten corners.

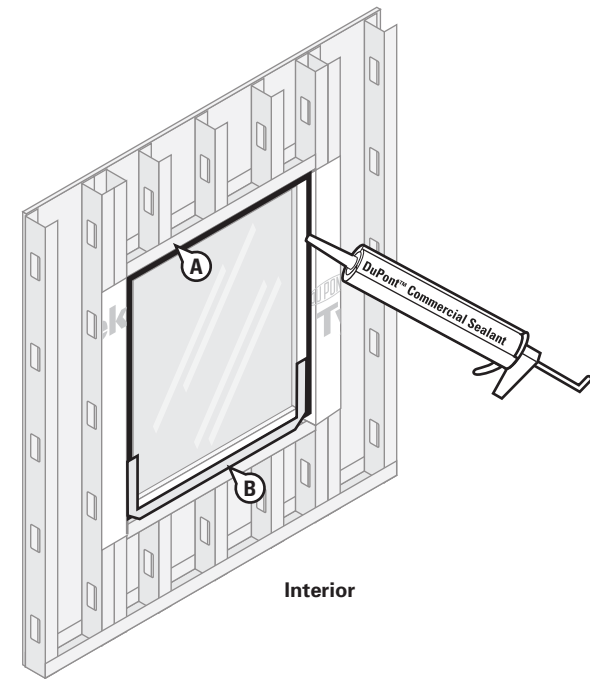

Back dam

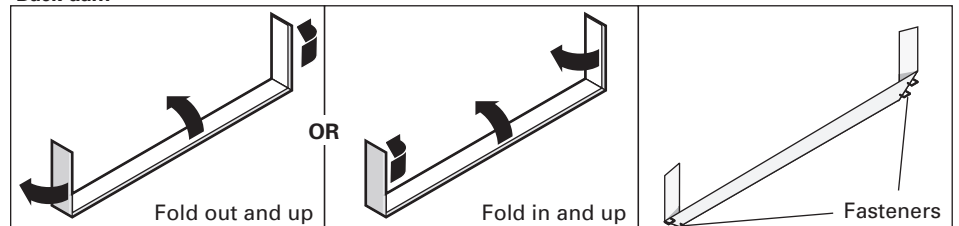

Installation Methods for DuPont Flashing Systems products AFTER DuPont™ Tyvek® Weather Barrier is Installed

Store front Window on Slab

Method applies to following products:

- DuPont™ StraightFlash™
- DuPont™ FlexWrap™
- DuPont™ FlexWrap™ NF

STEP 1

A. Cut rough opening in sheathing for window.

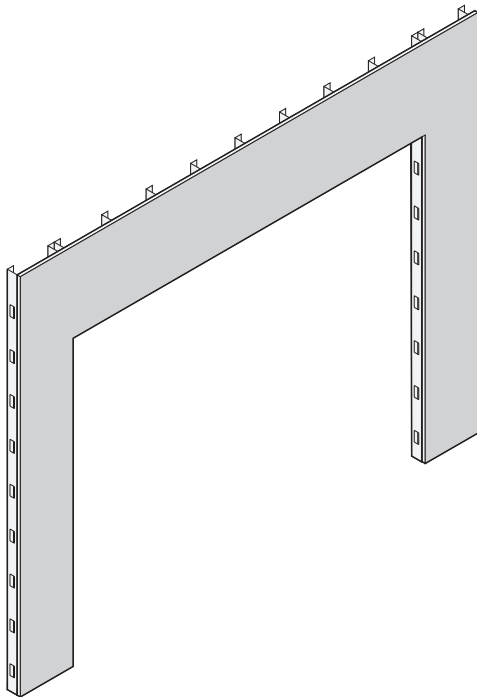

STEP 2

A. Wrap wall as shown in Installation Guidelines for DuPont™ Tyvek® weather barrier that can be found at www.construction.tyvek.com.

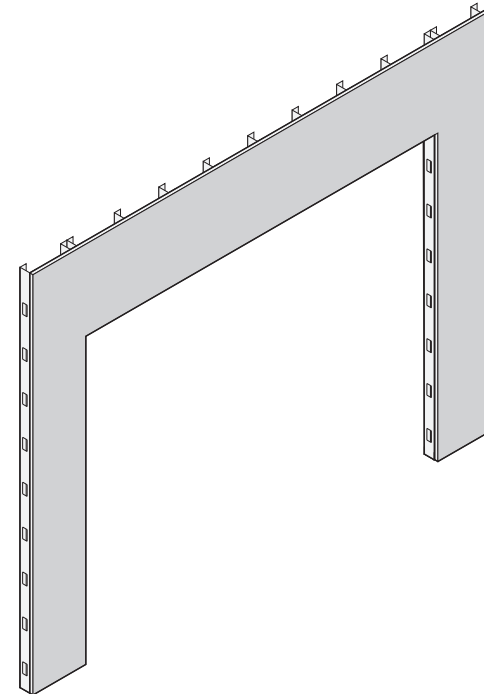

DuPont Flashing Systems Commercial Installation Guidelines

STEP 3

Prepare weather barrier for window installation.

- Cut an opening in the DuPont™ Tyvek® weather barrier using a square cut around the perimeter of the rough opening.
- Cuts should be made along the dashed indicated lines. (Ensure that the DuPont™ Tyvek® weather barrier is cut flush with the sheathing and is not wrapped into the rough opening.)
- Cut a head flap at 45° angle to expose 8" of sheathing to allow for head flashing installation.

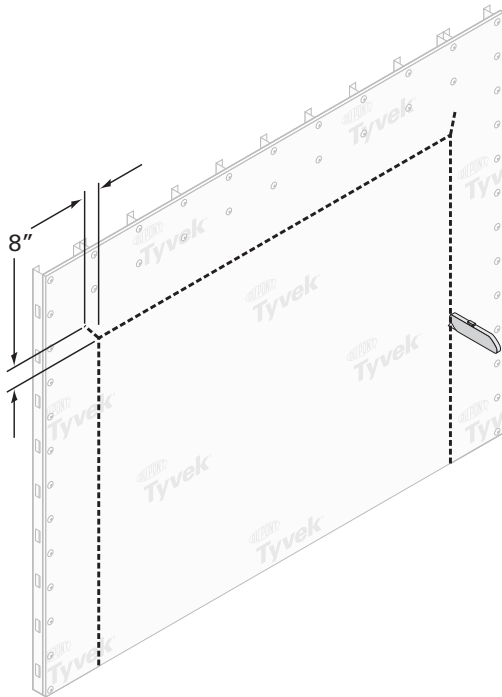

STEP 4

- Flip the head flap up to expose the sheathing and temporarily secure with tape.
- Temporarily secure DuPont™ Tyvek® weather barrier with DuPont™ Tyvek® Tape around rough opening before flashing is installed to help facilitate flashing installation.

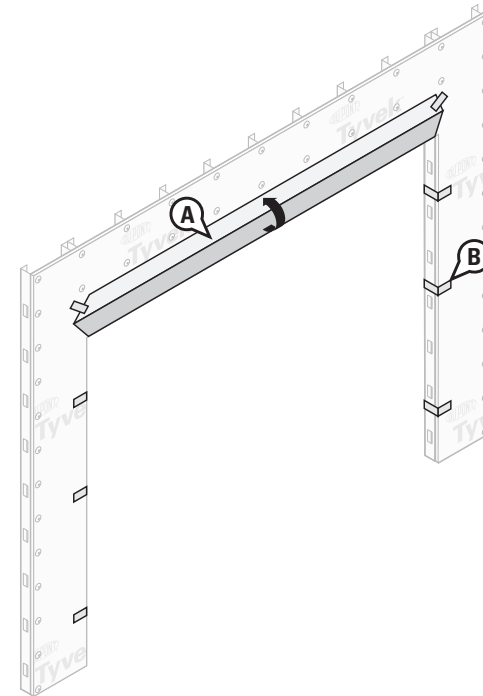

DuPont Flashing Systems Commercial Installation Guidelines

STEP 5

- A. Prepare the sill flashing per manufacturer's recommendation and seal the corner pan flashing with sealant.
- B. Inspect installation surface to ensure surface is free of dirt or substances that could interfere with adhesion as well as any sharp protrusions.

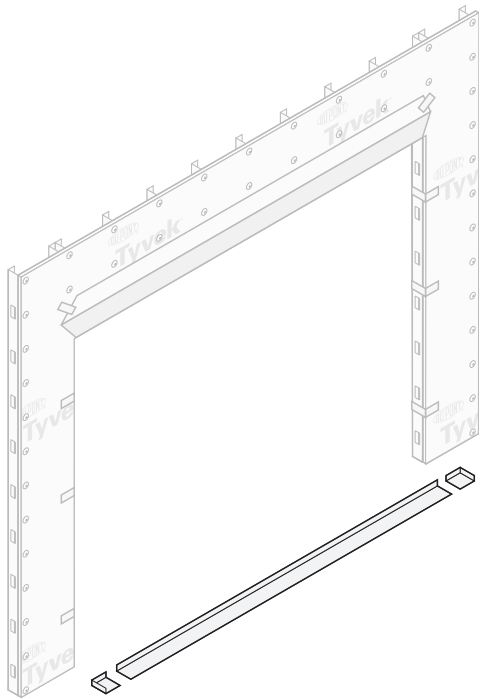

STEP 6

- A. Shim, level and anchor pan per manufacturer's instructions flashing to concrete.
- B. Seal corner pan flashing seams with DuPont™ Commercial Sealant or recommended sealant.

Option 2: An alternate approved flashing method is to install DuPont™ StraightFlash™ using installation method outlined in "Non-Flange Aluminum Window Using DuPont™ StraightFlash™ VF" on page 41.

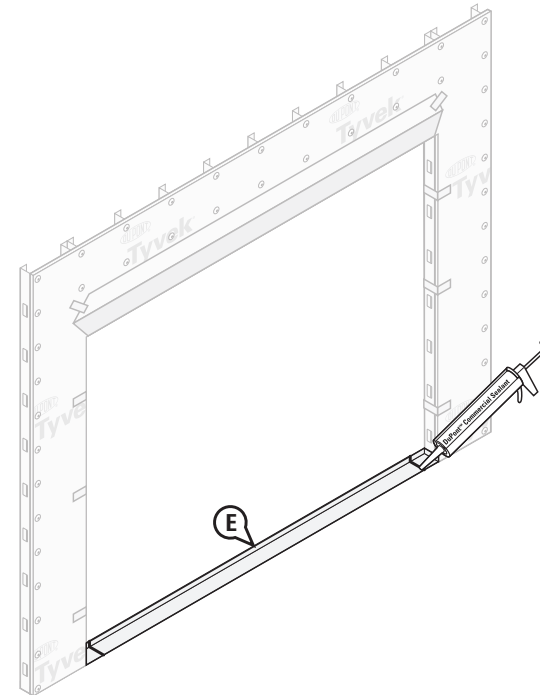

DuPont Flashing Systems Commercial Installation Guidelines

STEP 7

- A. Wrap 9" DuPont™ StraightFlash™ into the rough opening at each jamb and onto wall face. The flashing should align with the interior edge of the jamb framing. Cut the jamb flashing the vertical length of the rough opening.
- B. Jamb flashing should be long enough to overlap the sill flashing by at least 2" and be overlapped by future head flashing by at least 2".

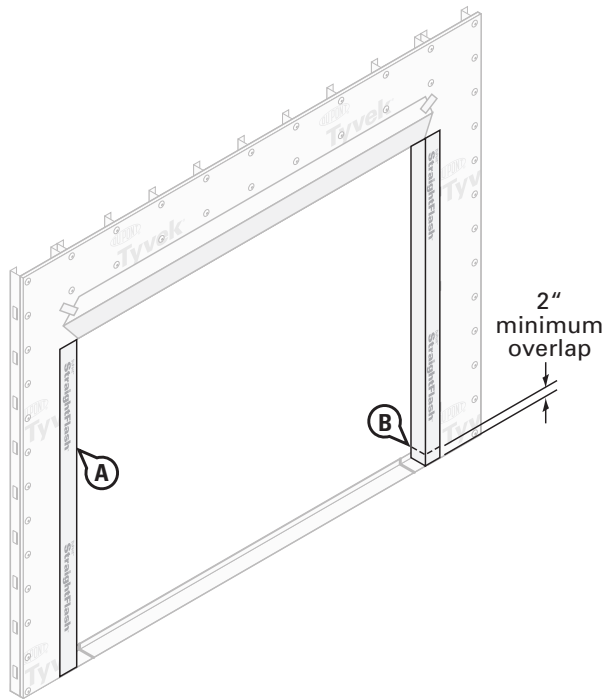

STEP 8

- A. Apply the top of the jambs and exposed sheathing with recommended primer.

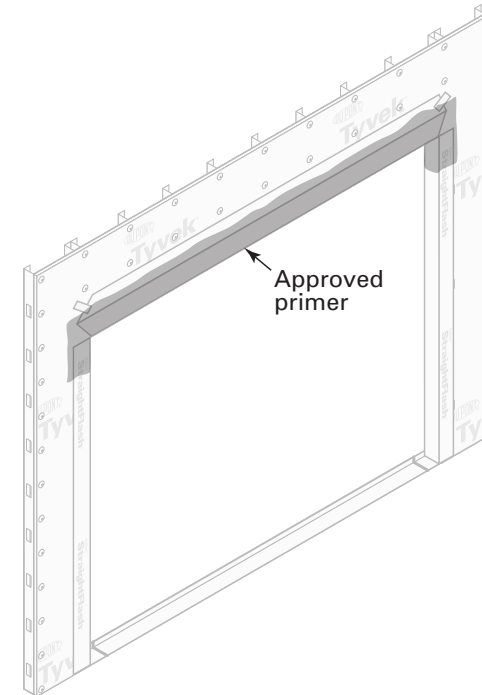

DuPont Flashing Systems Commercial Installation Guidelines

STEP 9

- Adhere DuPont™ FlexWrap™ or DuPont™ FlexWrap™ NF to the head. Make sure the DuPont™ FlexWrap™ is cut long enough to overlap the jamb flashing by at least 2".
- Use DuPont™ Tyvek® Wrap Cap fasteners to temporarily secure the outer edge of the flashing at the upper corners. (Commercial Wrap Cap screws are recommended for steel stud framing.) Flashing bond will strengthen over time. If using DuPont™ FlexWrap™ NF fasteners are not required.
- Use sufficient width of DuPont™ FlexWrap™ or DuPont™ FlexWrap™ NF to avoid reverse shingling of flashing at the jamb and head interface. See detail below.

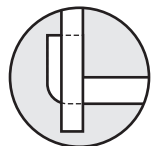
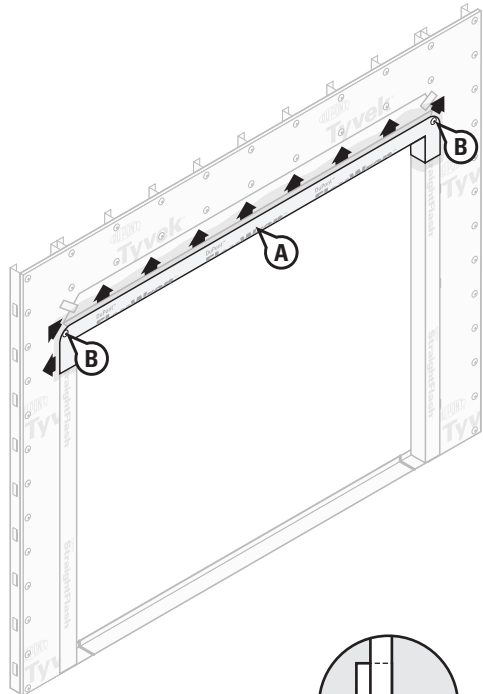

INCORRECT
DuPont™ FlexWrap™
reverse flashed

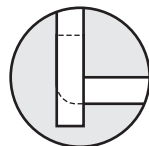

INCORRECT
DuPont™ StraightFlash™
flush with DuPont™
FlexWrap™

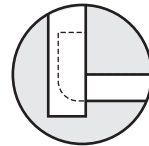

CORRECT
DuPont™ StraightFlash™
overlaps DuPont™
FlexWrap™

STEP 10

- Flip down the head flap and adhere 4" DuPont™ StraightFlash™ over the diagonal seams.
- Tape along the top of the window with DuPont™ Tyvek® Tape or 4" DuPont™ StraightFlash™.
- Install remaining DuPont™ Tyvek® Wrap Caps at head per the recommended spacing (every 12" to 18" depending on the vertical stud line).
- Install store front window frame into opening per manufacturer's instructions.

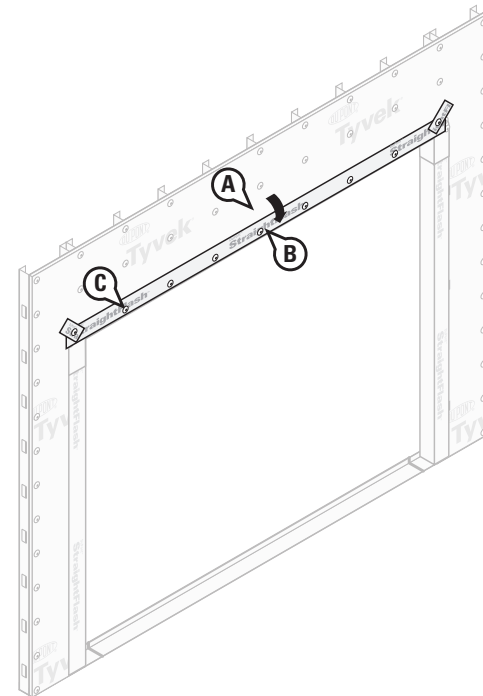

DuPont Flashing Systems Commercial Installation Guidelines

STEP 11

- A. Install store front window per manufacturers installation instructions.
- B. Glaze windows per manufacturers instructions.

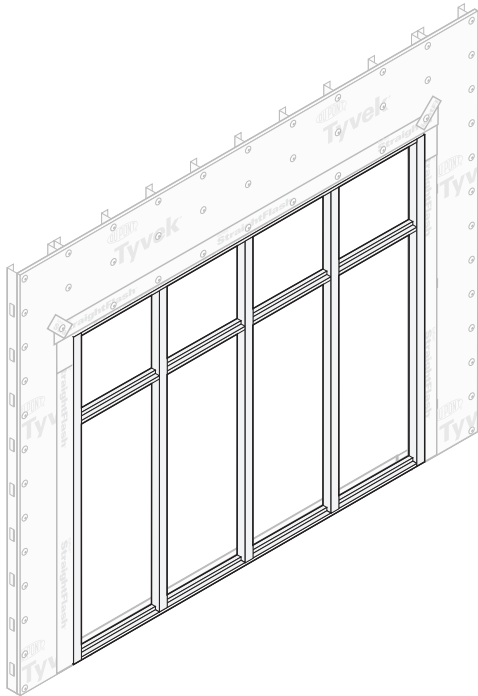

STEP 12

- A. Create a continuous perimeter seal with backer rod and DuPont™ Commercial Sealant on window interior to resist air and water infiltration.

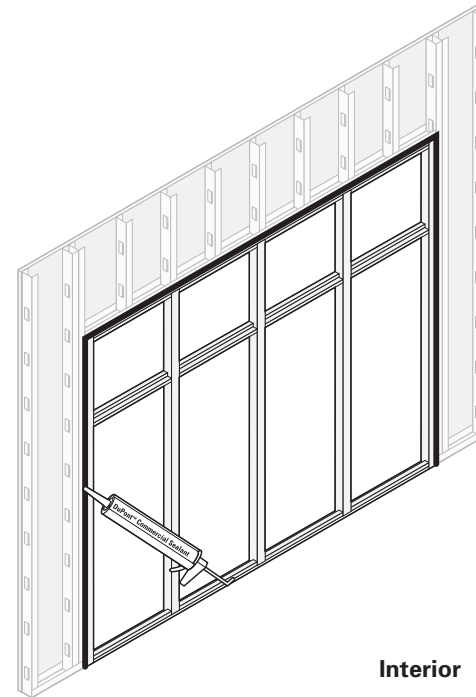

Interior

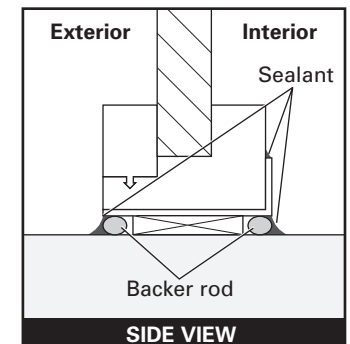

Installation Methods for DuPont Flashing Systems products AFTER DuPont™ Tyvek® Weather Barrier is Installed

Store front Window on Knee Wall

Method applies to following products:

- DuPont™ StraightFlash™
- DuPont™ FlexWrap™
- DuPont™ FlexWrap™ NF

STEP 1

A. Cut rough opening in sheathing for window. Ensure that sheathing is cut flush with, or slightly below the sill framing to allow for positive drainage.

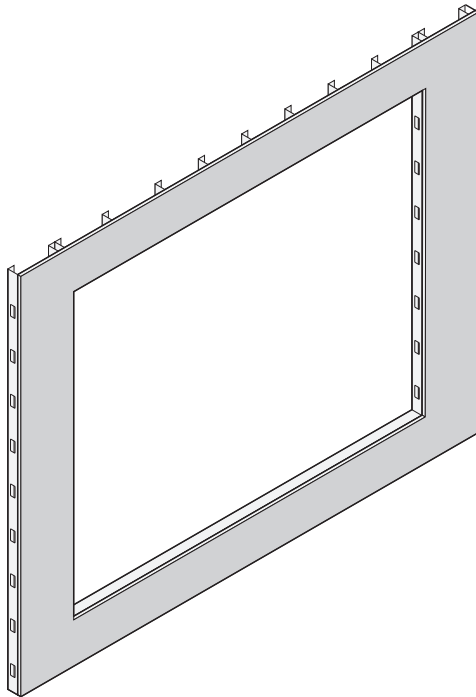

STEP 2

A. Wrap wall as shown in Installation Guidelines for DuPont™ Tyvek® weather barrier that can be found at www.construction.tyvek.com.

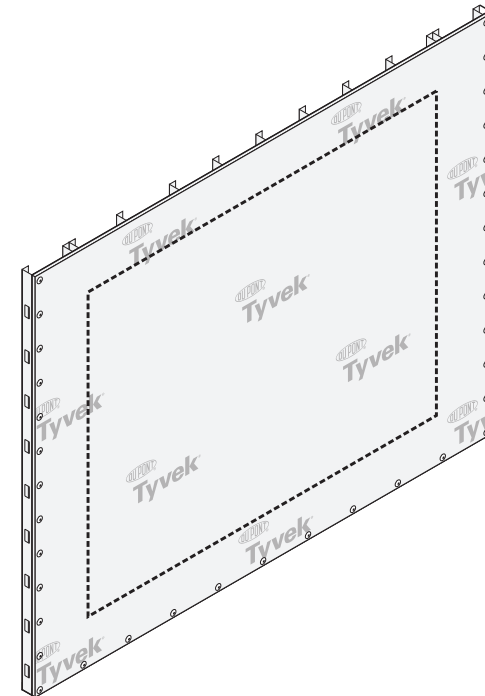

DuPont Flashing Systems Commercial Installation Guidelines

STEP 3

Prepare weather barrier for window installation.

- Cut an opening in the DuPont™ Tyvek® weather barrier using a square cut around the perimeter of the rough opening.
- Cuts should be made along the dashed indicated lines. (Ensure that the DuPont™ Tyvek® weather barrier is cut flush with the sheathing and is not wrapped into the rough opening.)
- Cut a head flap at 45° angle to expose 8" of sheathing to allow for head flashing installation.

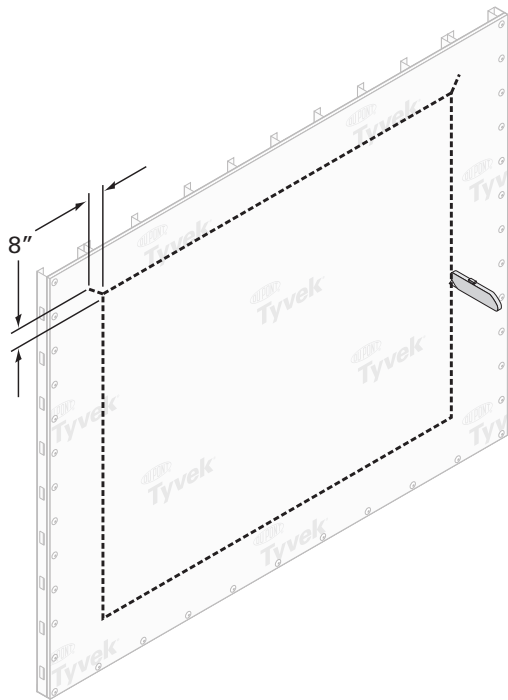

STEP 4

- Flip the head flap up to expose the sheathing and temporarily secure with tape.
- Temporarily secure DuPont™ Tyvek® Weather Barrier with DuPont™ Tyvek® Tape around rough opening before flashing is installed to help facilitate flashing installation.

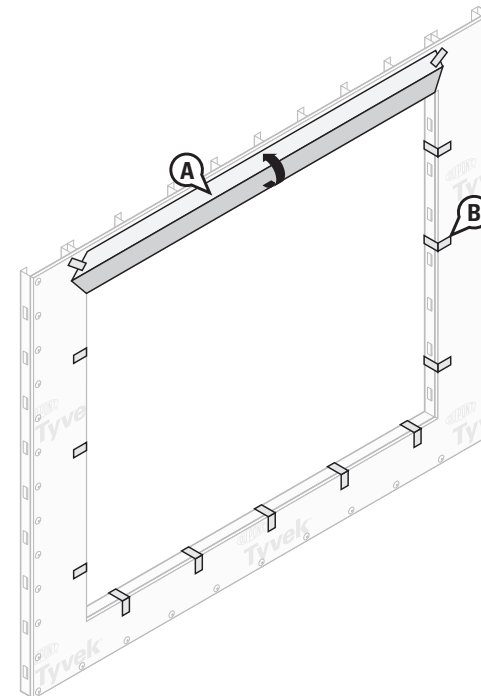

DuPont Flashing Systems Commercial Installation Guidelines

STEP 5

- A. Prepare the sill flashing by cutting a piece of DuPont™ FlexWrap™ that is at least 12" longer than sill length. Use 7" DuPont™ 0FlexWrap™ or 6" DuPont™ FlexWrap™ NF for 2 x 4 framing and 9" DuPont™ FlexWrap™ or 9" DuPont™ FlexWrap™ NF for 2 x 6 framing.
- B. Inspect installation surface to ensure surface is free of dirt or substances that could interfere with adhesion as well as any sharp protrusions.

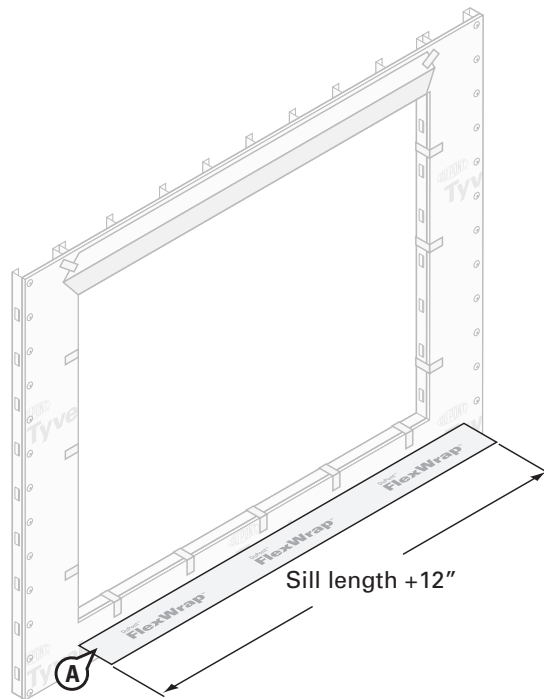

STEP 6

- A. Install the sill flashing. Remove the largest strip of release paper, align the flashing with the interior edge of sill, and install into rough opening across sill and up jambs (min 6"). Apply working from the middle of the sill towards the sides. Secure DuPont™ FlexWrap™ tightly into the corners by first working in along the sill before adhering up the jambs.

DO NOT STRETCH MATERIAL ALONG THE SILL OR JAMBS.

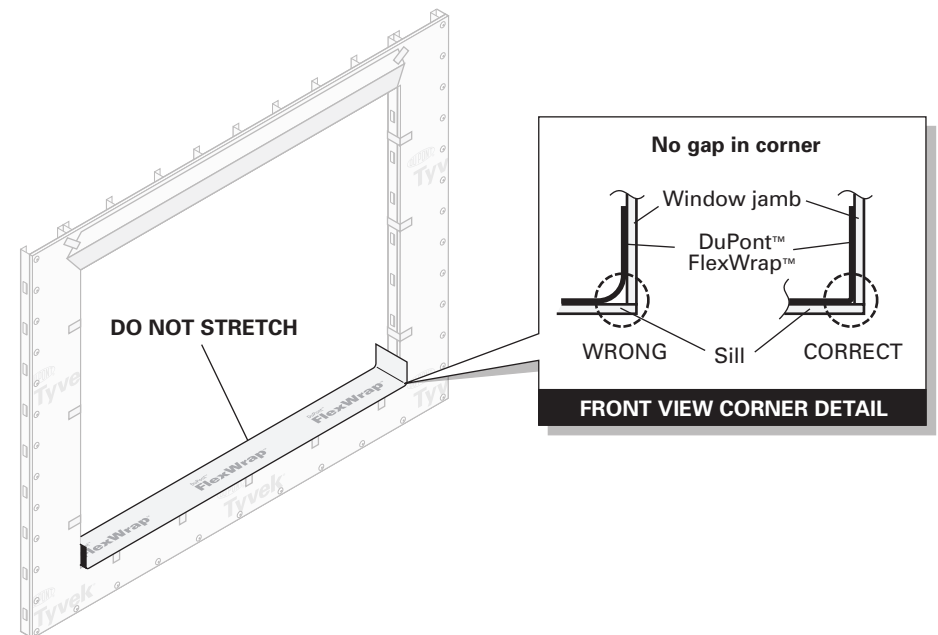

DuPont Flashing Systems Commercial Installation Guidelines

STEP 7

- A. Remove second half of the release paper.
- B. Fan DuPont™ FlexWrap™ or DuPont™ FlexWrap™ NF at bottom corners and adhere onto face of wall.
- C. Firmly press sill flashing to ensure full adhesion on all surfaces. Eliminate wrinkles and bubbles by smoothing surface and repositioning as necessary.
- D. Use DuPont™ Tyvek® Wrap Cap fasteners to temporarily secure the outer edge of the flashing at the lower corners. (Self tapping Wrap Cap screws are recommended for steel stud framing.) Flashing bond will strengthen over time. If using DuPont™ FlexWrap™ NF fasteners are not required.
- E. Shim, level and anchor sill pan flashing and seal corner seams per manufacturer's instructions with DuPont™ Commercial Sealant or recommended sealant.

Option 2: An alternate approved flashing method is to install DuPont™ StraightFlash™ using installation method outlined in "Non-Flange Aluminum Window Using DuPont™ StraightFlash™ VF" on page 41.

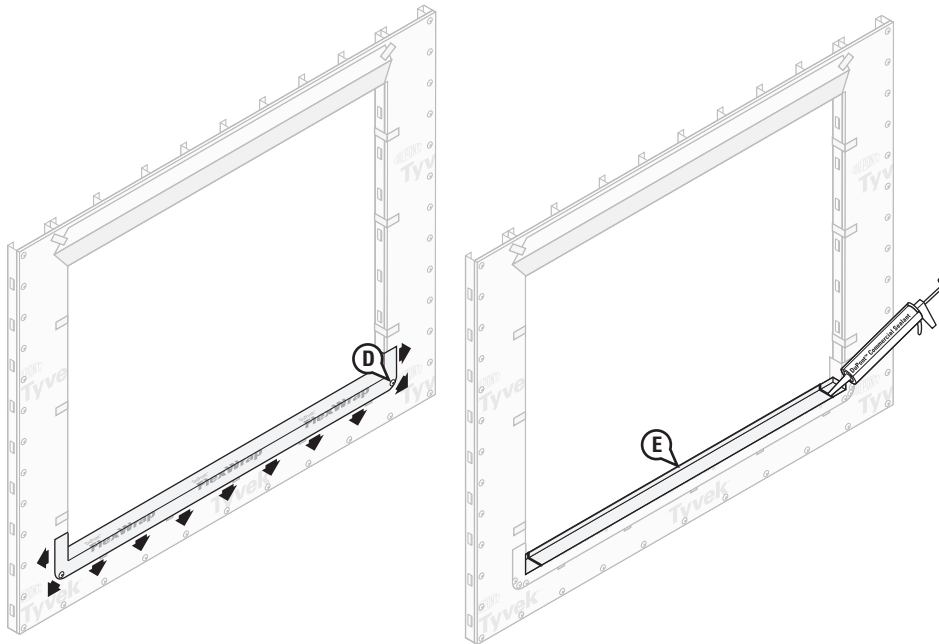

STEP 8

- A. Wrap 9" DuPont™ StraightFlash™ into the rough opening at each jamb and onto wall face. The flashing should align with the interior edge of the jamb framing. Cut the jamb flashing the vertical length of the rough opening.
- B. Jamb flashing should be long enough to overlap the sill flashing by at least 2" and be overlapped by future head flashing by at least 2" .

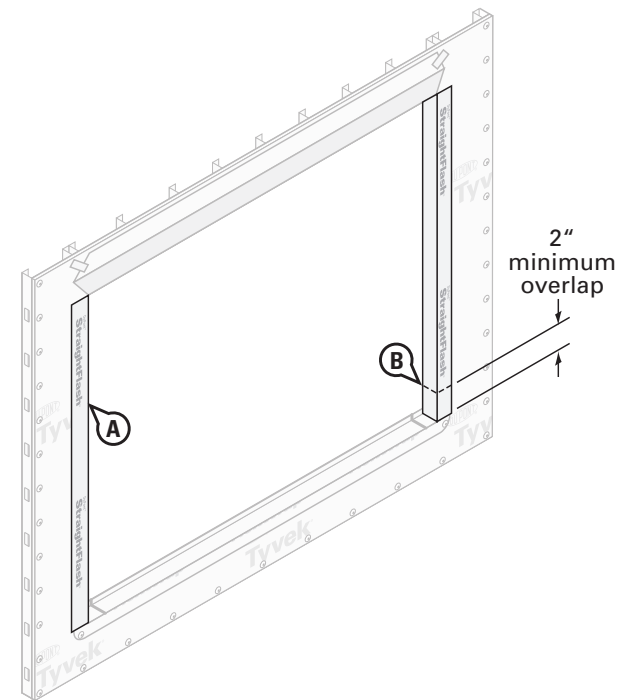

DuPont Flashing Systems Commercial Installation Guidelines

STEP 9

A. Spray the top of the jambs and exposed sheathing with recommended primer.

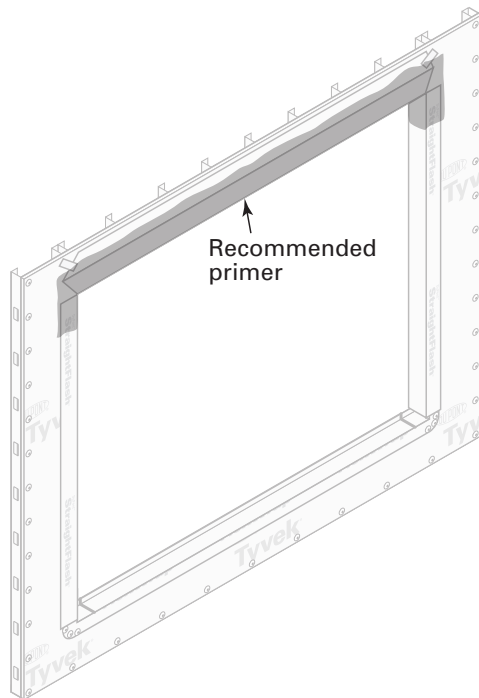

STEP 10

- A. Adhere DuPont™ FlexWrap™ or DuPont™ FlexWrap™ NF to the head using the same installation process as shown in steps 6 and 7 for the sill flashing. Make sure the DuPont™ FlexWrap™ is cut long enough to overlap the jamb flashing by at least 2".
- B. Use DuPont™ Tyvek® Wrap Cap fasteners to temporarily secure the outer edge of the flashing at the upper corners. (Commercial Wrap Cap screws are recommended for steel stud framing.) Flashing bond will strengthen over time. If using DuPont™ FlexWrap™ NF fasteners are not required.

NOTE: For alternate head detail see Step 6 of this Installation Guide.

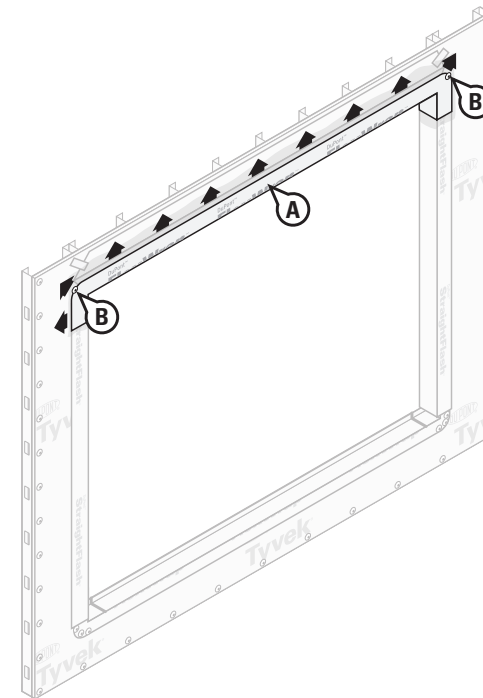

DuPont Flashing Systems Commercial Installation Guidelines

STEP 11

- A. Install storefront window per manufacturer's installation instructions.
- B. See steps 12–16 if the optional skirt flashing is desired. (Installation methods for DuPont Flashing Systems AFTER DuPont™ Tyvek® weather barriers is installed – for non-flanged windows.)

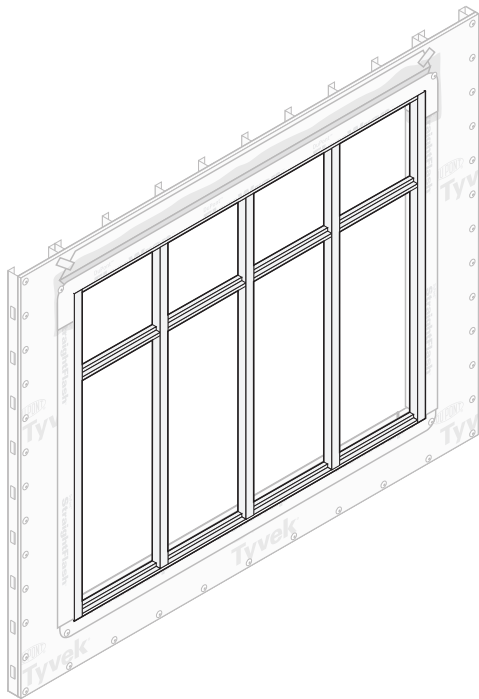

STEP 12

- A. Flip down the head flap and adhere 4" DuPont™ StraightFlash™ over the diagonal seams.
- B. Tape along the top of the window with DuPont™ Tyvek® Tape or 4" DuPont™ StraightFlash™.
- C. Install remaining DuPont™ Tyvek® Wrap Caps at head per the recommended spacing (every 12" to 18" depending on the vertical stud line).

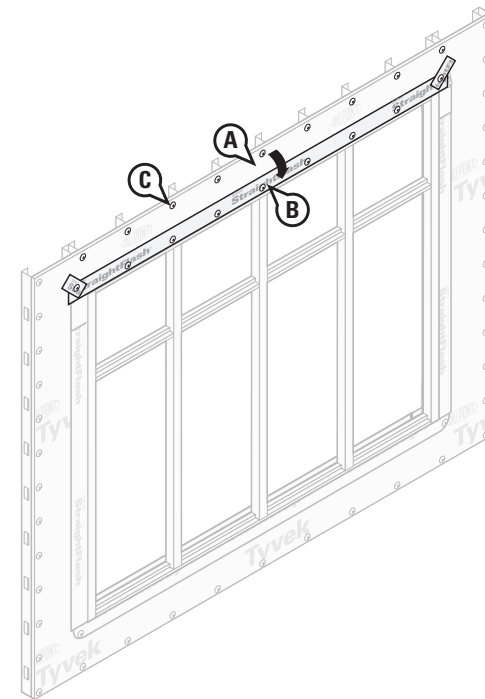

DuPont Flashing Systems Commercial Installation Guidelines

STEP 13

Interior view

- A. Create a continuous perimeter seal with backer rod and DuPont™ Commercial Sealant or recommended sealant on window interior to resist air and water infiltration.
- B. When the facade is complete, place a continuous sealant bead integrating the window to the facade.

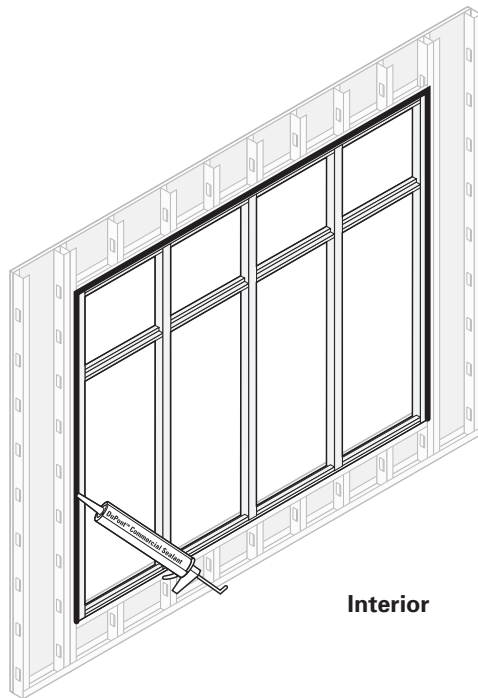

SIDE VIEW DETAIL

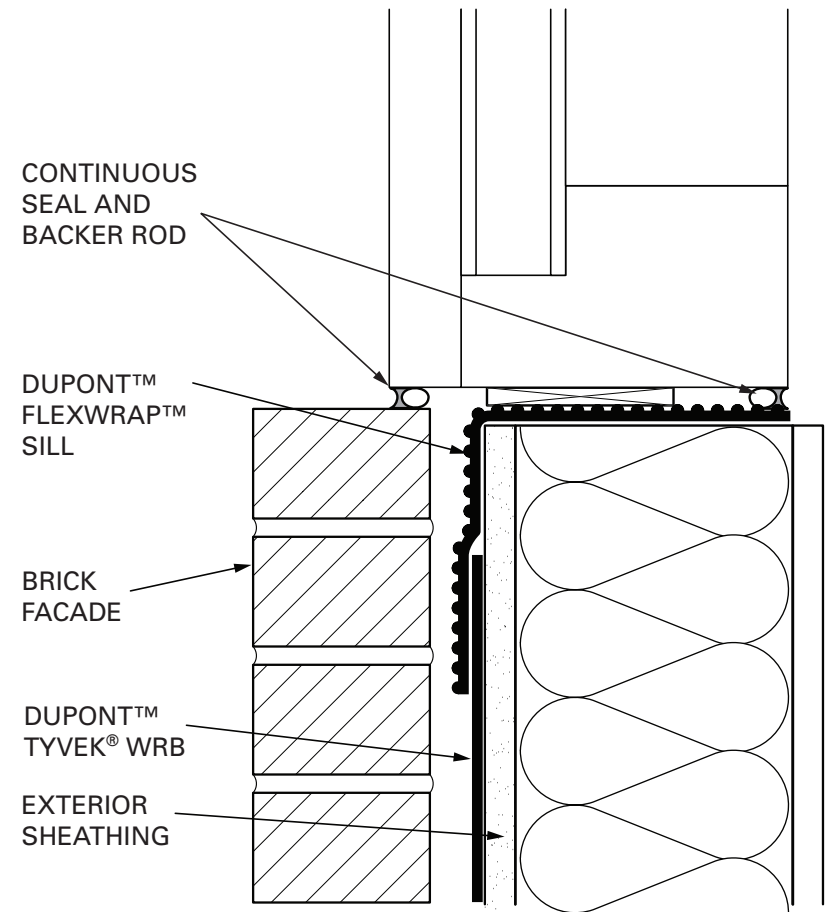

DUPONT™ THRU-WALL FLASHING – DUPONT™ TYVEK® INTERFACE

Window Head Detail

STEP 1

- A. Install window flashing (ie. DuPont Flashing Systems products) per manufacturer's guidelines.
- B. Cut flap in DuPont™ Tyvek® weather barrier.
- C. Apply DuPont recommended primer to exposed sheathing.
- D. Install lintel on masonry as required. DuPont™ End Dams should extend a minimum of 4" beyond the edge of the window opening.

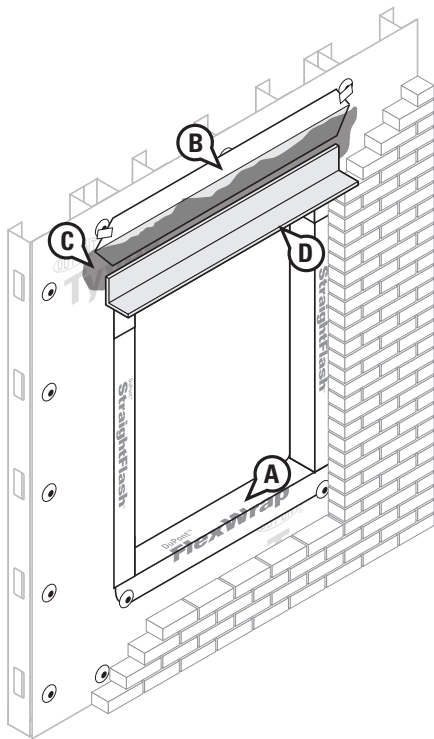

STEP 2

- A. Install 9" wide strip of DuPont™ Thru-Wall Flashing to bridge between the exterior sheathing and metal pan flashing. Maintain a minimum of 3" contact between the DuPont™ Thru-Wall Flashing and the primed exposed sheathing surface.

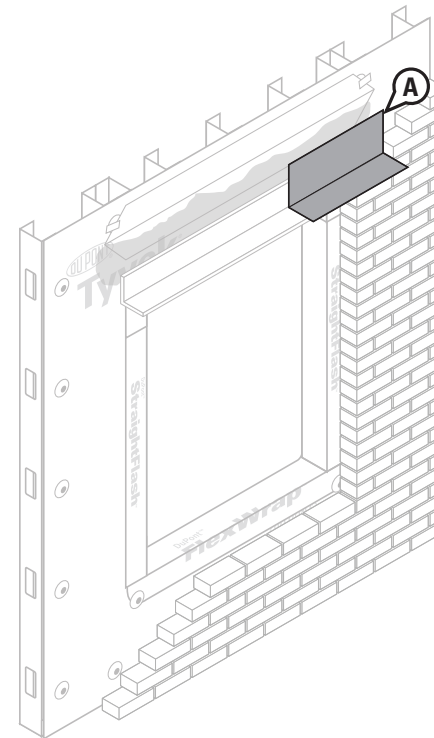

DuPont Flashing Systems Commercial Installation Guidelines

DUPONT™ THRU-WALL FLASHING – DUPONT™ TYVEK® INTERFACE

Window head detail (continued)

STEP 3

- A. Install DuPont™ End Dams beaded in recommended sealant.
- B. Install DuPont™ Thru-Wall Flashing with a minimum of 2" adhering to the wall sheathing, then overlapping the lintel. Extend the DuPont™ Thru-Wall Flashing a minimum of 1/4" beyond the outside edge of the lintel to form a drip edge.
- C. Apply DuPont™ Commercial Sealant or recommended sealant along DuPont™ Thru-Wall Flashing edges.

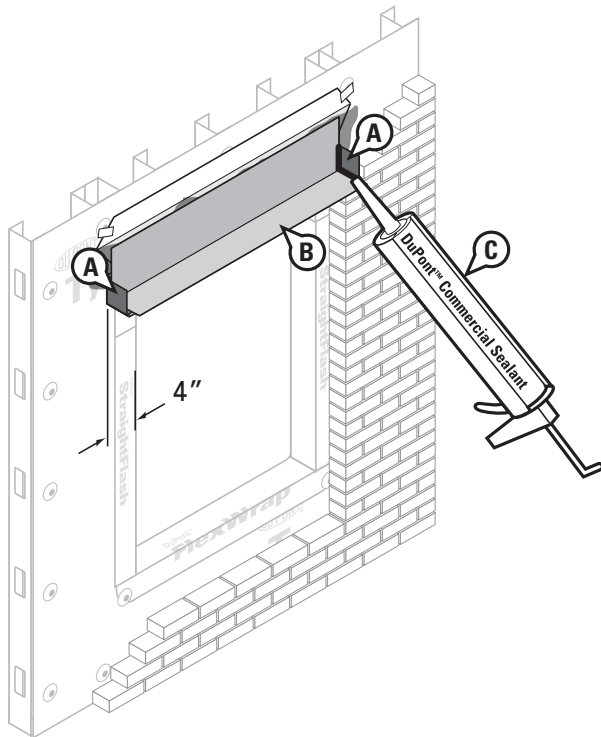

STEP 4

- A. Fold head flap back into place.
- B. Apply DuPont™ StraightFlash™ along bottom edge of cut in DuPont™ Tyvek® weather barrier with DuPont™ StraightFlash™.
- C. Use 4" wide pieces of DuPont™ StraightFlash™ to seal diagonal cut in DuPont™ Tyvek® weather barrier.
- D. Secure head flap with DuPont™ Tyvek® Wrap Cap fasteners.

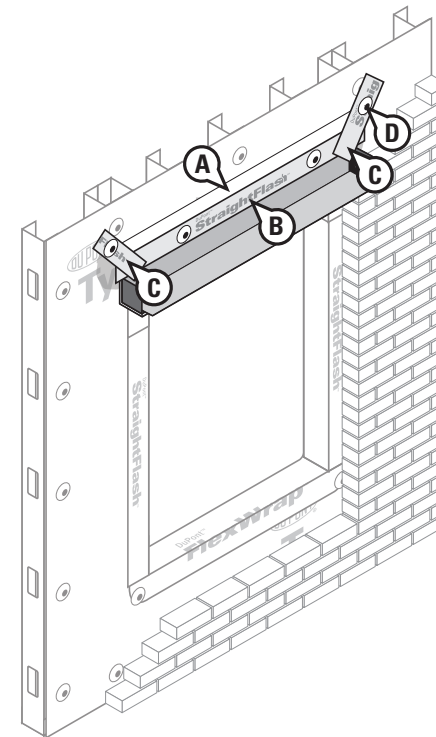

DuPont Flashing Systems Commercial Installation Guidelines

DUPONT™ THRU-WALL FLASHING INSTALLATION

Base of Wall With Outside Corner

- A. Apply a DuPont recommended primer. Following primer manufacturer's guidelines for appropriate coverage and drying times. Re-prime surface if primed area is left exposed >24 hours. (See page 3 General Instructions)
- B. Install preformed corners and end dams bedded in DuPont™ Commercial Sealant or recommended sealant in the appropriate locations along wall.
- C. Starting at a corner, remove the release sheet from the DuPont™ Thru-Wall Flashing, and apply membrane to primed surfaces in lengths of 8-10'.
- D. Extend the membrane completely through the wall and leave 1/4" minimum exposed to form a drip edge.
- E. Using a steel roller and firm hand pressure, roll the flashing into place to ensure continuous and direct contact with the substrate.
- F. End laps must be a minimum of 4" and overlap preformed corners a minimum of 4". Seal all laps with a manufacturer recommended sealant.
- G. (Optional) When using a metal drip plate, trim the exterior edge of the membrane 1" and secure per manufacturer's guidelines.
- H. Terminate the membrane on the vertical wall per plans and specifications. (Optional) Terminate into a reglet, counterflashing, or with a termination bar.
- I. DuPont™ Thru-Wall Flashing must be continuously supported by the substrate, must have no wrinkling, and must not span gaps or voids in excess of 1/2".
- J. Apply a sealant bead at each termination of the membrane with DuPont™ Commercial Sealant or recommended sealant.

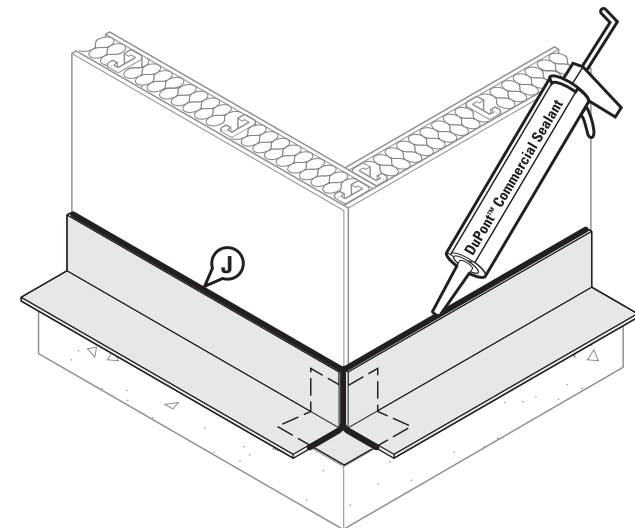
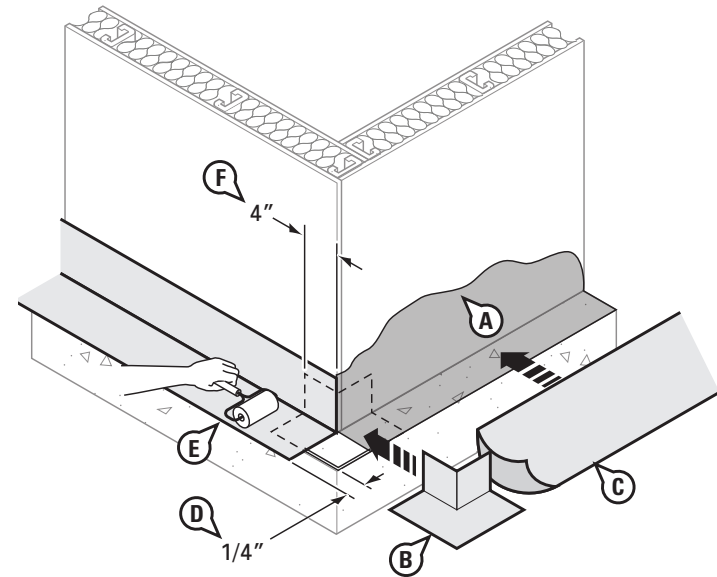

DuPont Flashing Systems Commercial Installation Guidelines

DUPONT™ THRU-WALL FLASHING – DUPONT™ TYVEK® INTERFACE

Base of wall

- Overlap DuPont™ Thru-Wall Flashing by 6".
- Mechanically fasten bottom of DuPont™ Tyvek™ weather barrier through top of the DuPont™ Thru-Wall Flashing.
- Seal vertical and horizontal seams using 3" DuPont™ Tyvek® Tape or DuPont™ StraightFlash™.

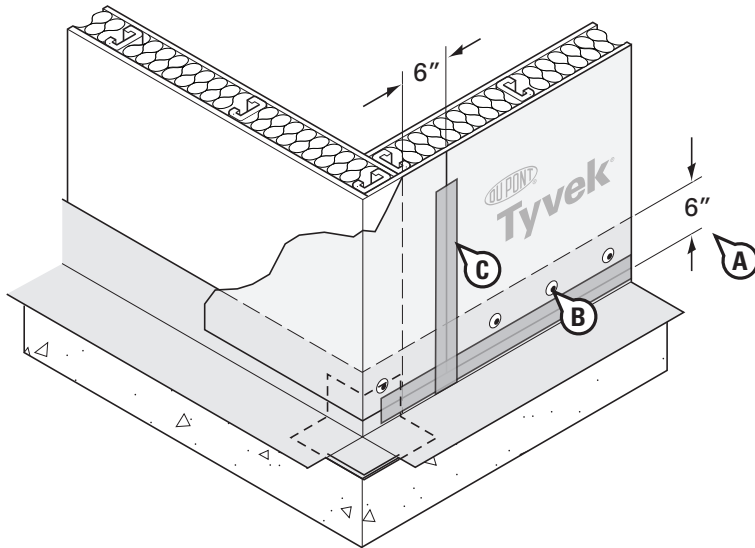

DUPONT™ THRU-WALL FLASHING – DUPONT™ TYVEK® INTERFACE

Shelf angle

- Seal the DuPont™ Tyvek® weather barrier to the bottom of the shelf angle using DuPont Flashing Systems products.
- DuPont™ Thru-Wall Flashing should be applied to the top of the shelf angle and the DuPont™ Tyvek® weather barrier should be properly shingled over by at least 6".
- Extend the membrane through the wall and leave 1/4" minimum exposed to form a drip edge.
- Seal bottom of the DuPont™ Tyvek® weather barrier to the DuPont™ Thru-Wall Flashing using 3" DuPont™ Tyvek® Tape or DuPont™ StraightFlash™.
- Install brick tie base plate with a DuPont™ StraightFlash™ patch or DuPont recommended alternate.

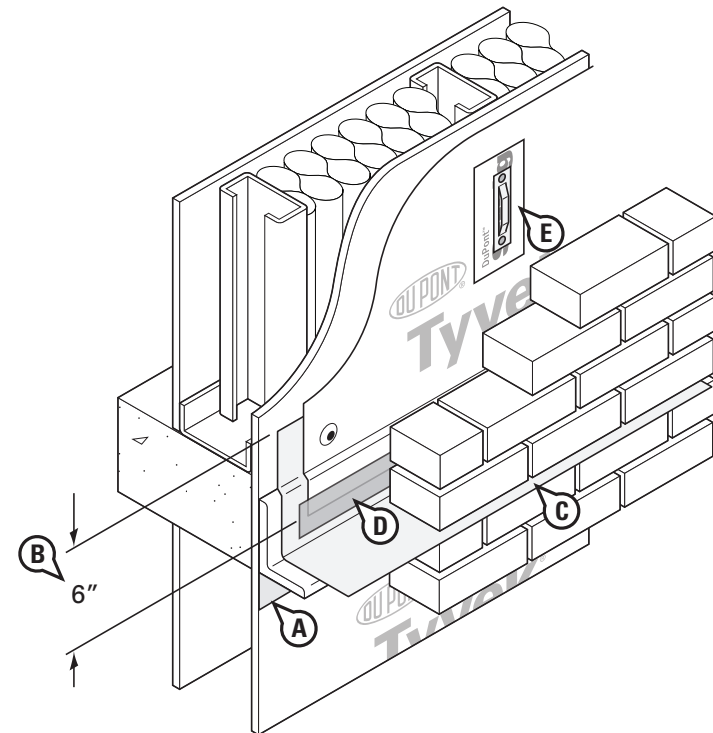

DuPont Flashing Systems Commercial Installation Guidelines

DUPONT™ THRU-WALL FLASHING – DUPONT™ TYVEK® INTERFACE

Parapet wall

- A. Install roofing membrane
- B. Apply DuPont™ Thru-Wall Flashing over parapet wall, overlapping the DuPont™ Tyvek® weather barrier and the roofing membrane in the proper shingling manner.
- C. Install brick tie base plate with DuPont™ StraightFlash™ patch or DuPont recommended alternate.
- D. Install coping.

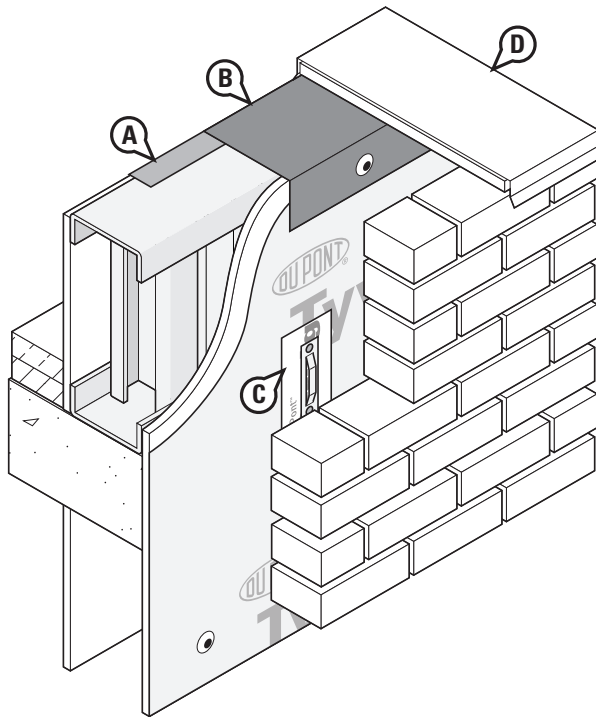

Two DuPont™ Thru-Wall Flashing Options

Option 1

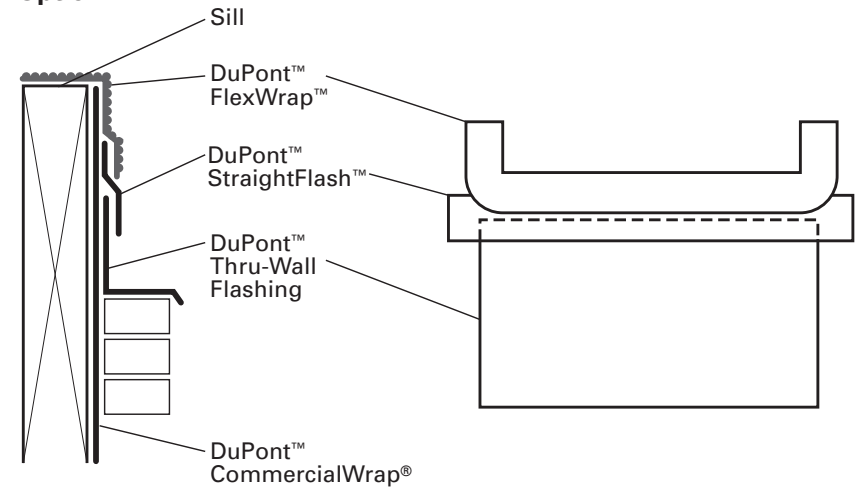

Option 2

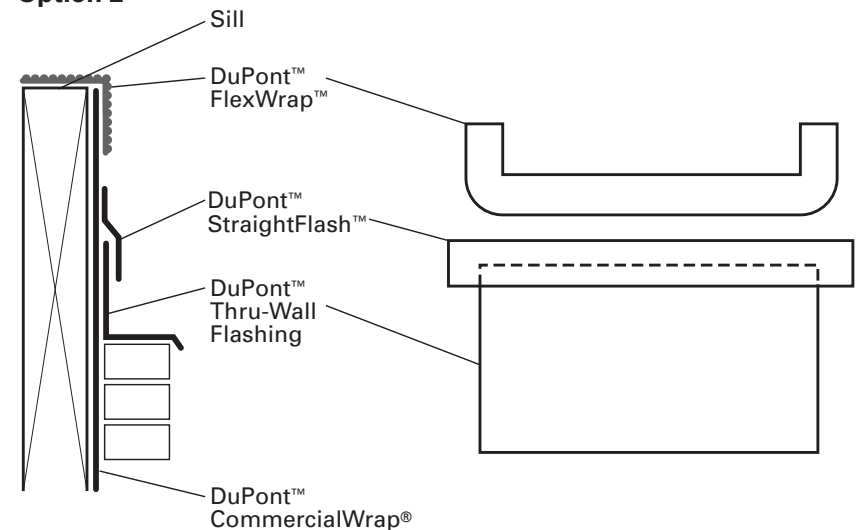

DuPont Flashing Systems Commercial Installation Guidelines

Penetrations

Seal the DuPont™ Tyvek® around all electrical, HVAC and plumbing penetrations with sealant and DuPont™ Tyvek® Tape, DuPont™ FlexWrap™ or DuPont™ FlexWrap™ NF. When using DuPont™ FlexWrap™ NF fasteners are not required. Products that have flanges should be integrated into the weather barrier using DuPont™ Tyvek® Tape or DuPont Flashing Systems products. DuPont™ StraightFlash™ or DuPont recommended alternate patches should be applied behind brick tie base plates and other metal fastening plates.

DuPont™ Tyvek® Tape should first be applied around penetration. DuPont™ Tyvek® Tape is used to reinforce the DuPont™ Tyvek® weather barrier. It is important that the tape be installed tight to the penetrating object. Next apply an adequate amount of DuPont™ Commercial Sealant or DuPont recommended sealant around the penetration.

STEP 1

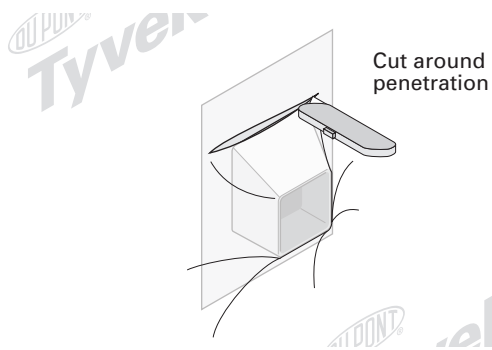

STEP 2

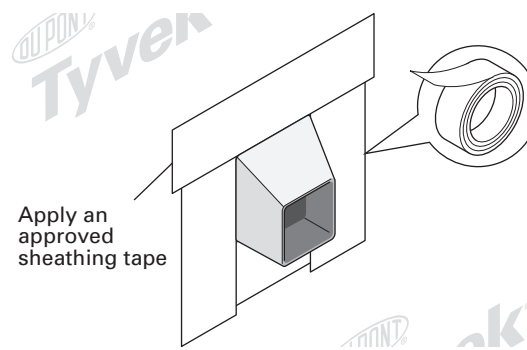

STEP 3

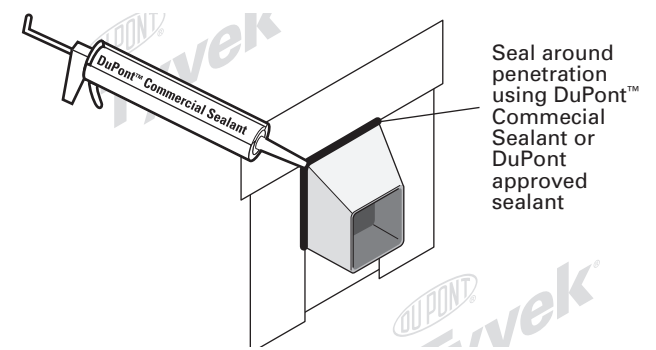

STEP 1

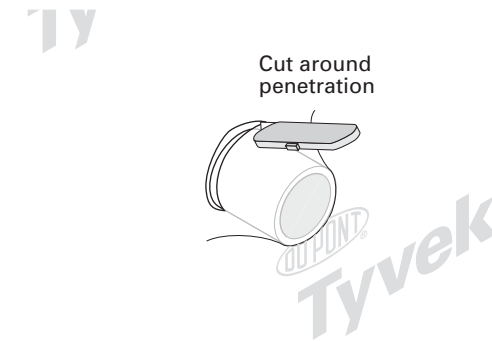

STEP 2

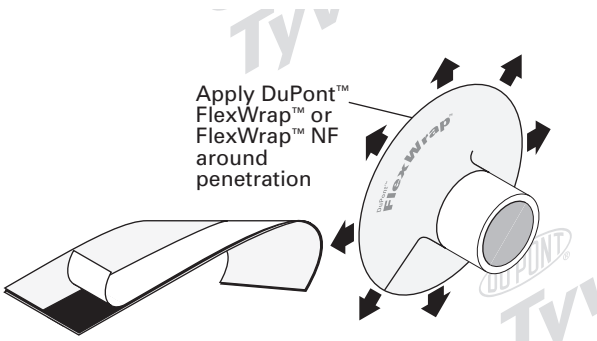

STEP 3

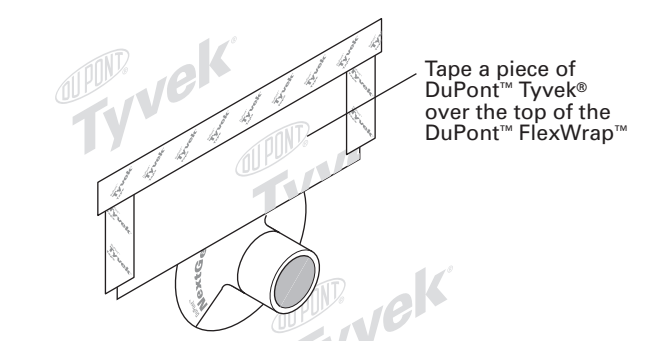

Technical Specifications

DuPont™ Tyvek® weather barriers used in construction products are made from 100% flash spunbonded high density polyethylene fibers which have been bonded together by heat and pressure, without binders or fillers, into a tough durable sheet structure. Additives have been incorporated into the polyethylene to provide ultraviolet light resistance. DuPont requires that DuPont™ Tyvek® CommercialWrap® and CommercialWrap® D be covered within nine months (270 days) of installation and DuPont™ Tyvek® ThermoWrap™ covered within four (4) months (120 days) of installation.

DuPont™ Thru-Wall Flashing is a 40 mil, self-adhesive composite flashing membrane. The top sheet is composed of DuPont™ Elvaloy® and thermoplastic ingredients that are reinforced with polyester fibers. A synthetic rubber adhesive is applied to the bottom surface of the membrane. A 1-1/2" edge of the top sheet does not have the synthetic rubber adhesive applied to it in order to provide a suitable surface for sealant adhesion and to use as a drip edge. Corners and end dams are made from DuPont™ Elvaloy® and thermoplastic ingredients. Additives have been incorporated to provide extended UV light resistance.

DuPont™ FlexWrap™ and StraightFlash™ flashing products are made from a synthetic rubber adhesive and a top sheet of flash spunbonded high density polyethylene fibers. Additives have been incorporated into these materials to help provide UV light resistance. DuPont requires that DuPont™ FlexWrap™ and DuPont™ be covered within four (4) months (120 days) of installation.

Warning

DuPont™ Tyvek® weather barriers are slippery and should not be used in any application where they will be walked on. In addition, because they are slippery, DuPont recommends using kickjacks, scaffolding, or lifts for exterior work above the first floor. If ladders must be used, extra caution must be taken to use them safely by following the requirements set forth in ANSI Standards 14.1, 14.2, and 14.5 for ladders made of wood, aluminum, and fiberglass, respectively. DuPont™ Tyvek® is combustible and should be protected from flames and other high heat sources. DuPont™ Tyvek® will melt at 275°F (135°C) and if the temperature of DuPont™ Tyvek® reaches 750°F (400°C), it will burn and the fire may spread and fall away from the point of ignition. For more information, call 1-800-44-Tyvek.

DuPont™ Thru-Wall Flashing, DuPont™ FlexWrap™, and DuPont™ StraightFlash™ products and their release paper are slippery and should not be walked on. Remove release paper from work area immediately. DuPont™ Thru-Wall Flashing will melt at temperatures greater than 480°F (250°C). DuPont™ FlexWrap™ and StraightFlash™ will melt at temperatures greater than 250°F (121°C). DuPont Flashing Systems products are combustible and should be protected from flame and other high heat sources. If burning occurs, ignited droplets may fall away from the point of ignition. For more information, call 1-800-44-Tyvek.

DuPont™ Weatherization Sealant is irritating to skin, eyes and respiratory tract. For proper usage, follow directions stated on the product label. For health information, refer to the Material Safety Data Sheet or call Chemtrec at 1-800-424-9300.

Note

When installed in conjunction with other building materials, DuPont Flashing Systems products must be properly shingled with these materials, such that water is diverted to the exterior of the wall system. DuPont™ Tyvek® products are secondary weather barriers, not the primary water barrier. The outer facade is the primary barrier. You must follow facade manufacturer's installation and maintenance requirements for all facade systems in order to maintain water holdout properties and ensure performance of DuPont™ Tyvek®. Use of additives, coatings or cleansers on or in the facade system may impact the performance of DuPont™ Tyvek® weather barriers. DuPont™ Tyvek® Weather Barrier Systems products are to be used as outlined in this installation guideline. For superior protection against bulk water penetration, DuPont suggests a system combining a quality exterior facade, a good secondary weather barrier and an exterior sheathing, appropriate flashing materials and details; and high quality windows and doors with particular attention to proper installation of each component. In a system where no exterior sheathing is used and DuPont™ Tyvek® is installed directly over the wall studs, exterior facade materials should be selected to ensure maximum protection against water intrusion. Careful workmanship and proper installation of each component is very important.

DuPont believes this information to be reliable and accurate. The information may be subject to revision as additional experience and knowledge is gained. It is the user's responsibility to determine the proper construction materials needed.

For complete warranty information please call 1-800-44-Tyvek.

To submit a warranty claim, please contact DuPont at www.construction.tyvek.com or call 1-800-44-Tyvek. Warranty coverage requires a submission of proof of purchase of the DuPont Weatherization Systems product(s) at issue.

This information is not intended to be used by others for advertising, promotion, or other publication for commercial purposes.

For more information about DuPont Weatherization Systems, please call 1-800-44-Tyvek or visit us at www.Construction.Tyvek.com



The Tyvek logo features the word "Tyvek" in a blue, sans-serif font. Above the text is a horizontal bar composed of several colored segments: blue, white, grey, and black.