

6 ADJUST REST OF FRAME & FASTEN (CONT...)

From the swing side of the door, shim above the screw locations and make adjustments so the margins between the door and frame are even top to bottom.

NOTE: For double doors, make adjustments that affect the alignment, margins and weatherstrip contact between the doors. Also follow the Astragal Site Package Instructions for details on properly setting the slide bolt hole locations. Re-check everywhere for plumb and square, and an even weatherstrip contact. Finish driving all screws tight.

7 REMOVE THE TRANSPORT CLIP & OPEN DOOR

Remove the transport clip. Open and close door to check for smooth operation.

With the door open at the top hinge, drill 1/8 inch diameter pilot holes in the screw hole locations closest to the weatherstrip (if no screws previously installed). If screws are previously installed, remove 3/4 inch screws and install #10 x 2-1/2 inch screws. For middle and bottom hinges, proceed to install one (1) #10 x 2-1/2" screw in the bottom hole, closest to the weatherstrip.

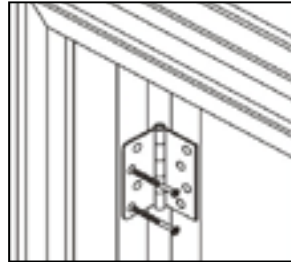

MAKE SURE all installed screws go through the hinge, into the stud, to anchor the door frame and prevent sagging.

7A SIDELITE AND PATIO UNITS THAT ARE CENTER HINGED

With the door open, check to determine if the 2-1/2 inch long hinge screws were pre-installed in the hinges. If not, drill 1/8 inch diameter pilot holes and install the long hinge screws in the hole locations closest to the weatherstrip.

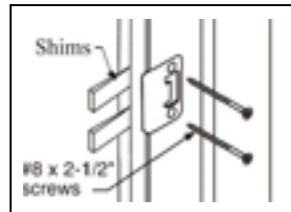

Close the door and carefully shim between the jamb and the opening behind the strike plate area.

Then open the door and drill 1/8 inch diameter pilot holes and install the #8 X 2-1/2 inch screws (provided) through the strike plate holes to secure the lock side jamb and provide security.

8 ADJUST THE SILL

Your door unit may have an adjustable threshold cap. When properly adjusted, it should be snug and slightly difficult to pull a dollar bill out from under the door when it is fully closed. The dollar bill should be able to be removed without tearing.

This check should be performed at each adjustment screw location.

After adjusting the threshold cap, ensure that the weatherstrip is flush with the top of the threshold cap. Trim as necessary.

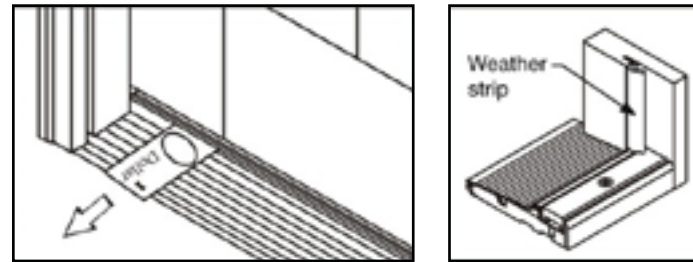

9 INSTALL CORNER SEAL PADS (IN SWING UNITS ONLY)

Apply sealant (polyurethane or elastomeric) at the joint where the threshold cap meets the door jambs.

Remove the self-stick paper from the corner seal pads and apply to the door jamb, with the bottom lined up evenly with the top of the threshold cap. When the pad is correctly installed, the tab is on top and the narrow part is on the bottom.

The bottom of the pad is the same width of the threshold cap to help with alignment during installation.

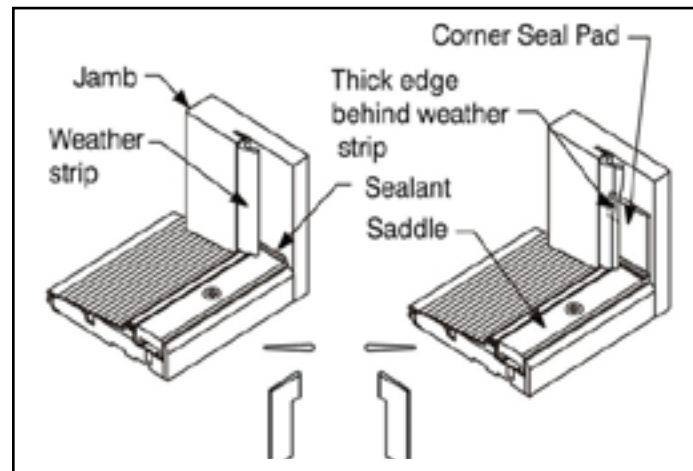

10 ADDITIONAL FRAME ANCHORING

If sill is prepared for anchoring screws, place appropriate screws through the sill into the subfloor where needed (primarily on outswing sills).

IMPORTANT: Provide additional frame anchoring as shown here. Certain states or jurisdictions, notably Florida and the coast of Texas, have specific installation requirements and may require installation in strict accordance with the product approval for a specific product. You should always check with the local authority having jurisdiction for any specific installation requirements that may apply.

Doors with Sidelites:

Shim above mull post or jambs separating doors and sidelites. Screw through the frame into the header, adjacent to the shims.



Double Doors:

Place temporary shims above the center of the head frame, where doors meet. Pre-drill and insert a screw through frame into header, then remove the temporary shims.

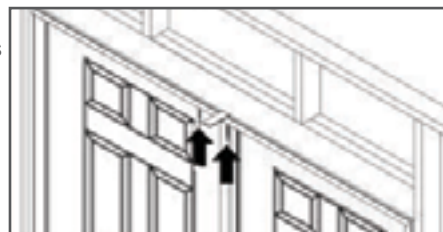

Patio Doors:

Shim above the mull post(s), pre-drill and insert a screw through the frame into the header, at either side of the post.

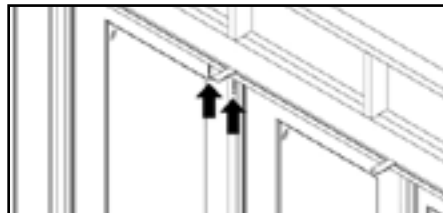

11 WEATHERPROOF FINISH & MAINTAIN

Provide and maintain a properly installed cap or head flashing to protect top of surfaces from water intrusion and damage. Tape and properly seal the top flap of the water resistive barrier (WRB) over the head flashing.

Caulk around entire "weather" side of unit, sealing along the brickmould to the flashing material or siding and seal all joints between the jambs and moldings.

Seal the joints between the exterior hardware trim and the door face to prevent air and water infiltration.

11 WEATHERPROOF FINISH & MAINTAIN (CONT...)

Place and set galvanized finish nails through the brickmould around the perimeter. Use exterior grade screws if you are installing a storm door to the brickmould. Countersink all fasteners and cover with exterior grade putty.

Add insulation material to the cavity between the opening and the unit to reduce air infiltration and heat transfer.

All ThermaTru doors must be finished within several days of the installation date for continued warranty coverage. For Fiberglass doors the finishing requirement is within 6 months of installation.

Paint according to ThermaTru Finishing instructions.

DO NOT paint or stain the weatherstrip, it is "friction-fit" and easily removed for painting or staining.

All 6 sides of the doors must be finished. For out-swing doors the sides, top and bottom must be inspected and maintained as regularly as all other surfaces.

All bare wood surfaces such as the door frame exposed to weather should be primed and painted, or stained and top coated within two weeks of exposure for best performance.

Maintain or replace sealants and finishes as soon as any deterioration is evident. For semi-gloss or glossy paint or clear coats, do this when the surface becomes dull or rough. More severe climates and exposures will require more frequent maintenance.

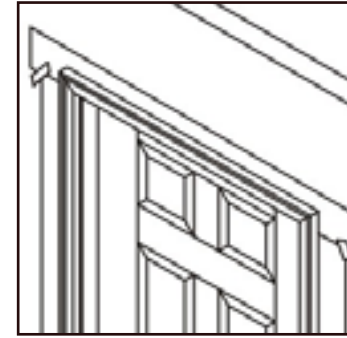

PREPARATION AND FINISHING

Work only when temperatures are between 50° and 90°F and with humidity less than 85%. Do not finish in direct sunlight.

Steel and Smooth Fiberglass Doors:

To paint Doors: Clean first with mild detergent and water or use a TSP (tri-sodium phosphate) solution. Rinse well and allow to dry completely. Mask off hardware, glass and remove weatherstripping before painting. Use high-quality acrylic latex house paint, following manufacturer's directions for application. Use exterior grade finishes for outside surfaces. Paint edges and exposed ends of door.

To Paint Door Lite Frames:

Remove any excess glass glazing sealant by first spraying with a window cleaner or water. Use a single edge razor blade to score the glazing along the edge of the frame. Holding the razor blade at a 45 degree angle, scrape glazing from glass. Wipe remaining residue off with window cleaner or mineral spirits. Clean frame with a mild detergent and water, or use a TSP solution. Rinse well and allow to dry completely. Mask off glass. Prime door lite frames with an alkyd- or acrylic-based primer. Allow primer to dry before applying finish paint coats. Use high-quality acrylic latex house paint, following manufacturer's application instructions. Use exterior grade finishes for outside surfaces.

To Paint Doors:

Clean first with mild detergent and water or use a TSP (tri-sodium phosphate) solution. Rinse well and allow to dry completely. Prime with an alkyd- or acrylic-based primer. Allow primer to dry completely, then paint with acrylic latex house paint, following paint manufacturer's application instructions. Use a primer and paint that are compatible. Use exterior grade finishes for outside surfaces. Paint edges and exposed ends of door.

WARNING: Modification or machining of this product can release wood dust, a substance known to the State of California to cause cancer.

THERMA TRU
DOORS

INSTALLATION GUIDE

Pre-Hung Exterior Fiberglass Doors



BEFORE YOU BEGIN

READ ALL INSTRUCTIONS AND REVIEW DIAGRAMS BEFORE BEGINNING THE INSTALLATION TO GET A THOROUGH UNDERSTANDING OF THE PROCESS.

INSTALLATION INSTRUCTIONS FOR PRE-HUNG DOOR SYSTEMS

These installation instructions are designed to assist door installers who have an understanding of carpentry principles, and know how to properly and safely use power tools. The purpose of these instructions is to illustrate how to install a ThermaTru door system using methods and materials that help eliminate water related leaks. If the directions are closely followed, the door system will have a long useful life with good resistance to rain related water intrusion problems.

These methods are "tried and true." They are used widely by builders and remodelers who are serious about managing and keeping water outside the home. If you remain unclear, please seek more professional assistance with the installation.

Different parts of the country have different code requirements, which may not be covered in these instructions. The installer is responsible for insuring the installation complies with local codes.

If disturbing existing paint, take proper precautions if lead paint is suspected (commonly used before 1979). For information regarding lead paint regulations, refer to www.epa.gov/lead. For products being removed, always ensure that these products are properly disposed of or recycled in accordance with local jurisdictional requirements.

NOTE: Provide a copy of these instructions to the building owner. By installing this product, you acknowledge the terms and conditions of the limited warranty as part of the terms of the sale.

USE WATER RESISTIVE BARRIER & FLEXIBLE FLASHING

We recommend the use of a Water Resistive Barrier (WRB) applied to the exterior sheathing (OSB or other) and the use of an adhesive or flexible flashing product to seal around the opening. The WRB should be cut in the opening (follow manufacturer's guidelines) with the head of the flap taped up, to be sealed later in Step 11. The flashing should be applied in an overlapping manner as shown, always working from the bottom up (follow manufacturer's guidelines). Use a sill pan: We recommend you first "dry fit" the sill pan in the opening, following the instructions furnished with the sill pan. Place the right and left sill pan ends tight against the sides of the opening. Check the center section for proper length and if necessary, cut with a hack saw or tin snips. Be sure to allow 2 inches of overlap at the joints.

NOTE: Use only the PVC cement provided in the sill pan kit to glue the pieces together. The sill pan must be sealed to the subfloor using an elastomeric or polyurethane sealant, but do not apply sealant to the bottom of the sill when using a sill pan.

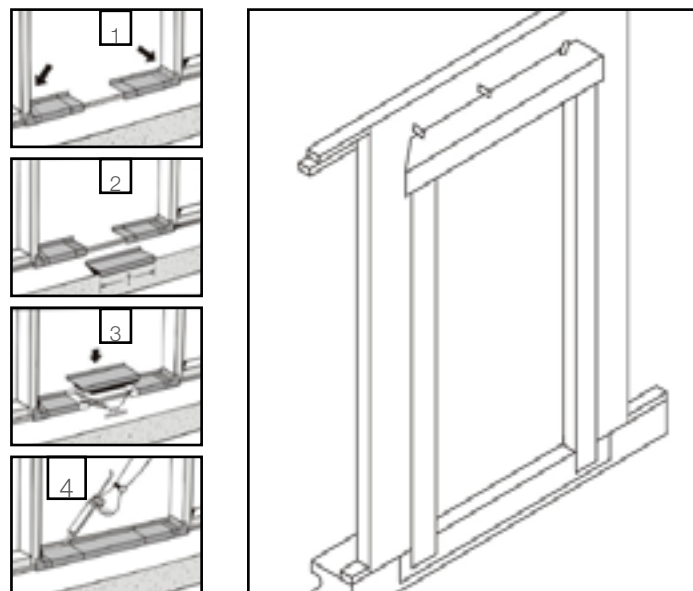

REQUIRED TOOLS & MATERIALS

WARNING: Cancer and Reproductive Harm
www.P65warnings.ca.gov



1 CHECK DOOR UNIT

Check width and height.

Measure size of frame (width and height), not brickmould.

Remove cleats and packaging, but keep door fastened and closed with the transport clip.

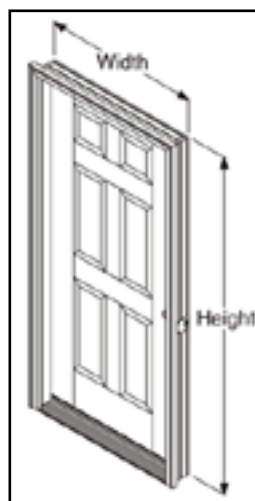

DO NOT remove the transport clip until instructed to do so, later in Step 7.

2 CHECK & PREPARE THE OPENING

Is the opening the correct size for the door unit? Check it against the door frame size now, before installation. The opening should be frame height plus 1/2 inch, and frame width plus 1/2 inch to 3/4 inch. Fix any problems now.

Are the framing and walls plumb? Use a 6-foot level and check both sides of the opening, both ways (front to back and right to left). Fix any problems now.

Is the subfloor level and solid? Provide a flat, level, clean weight bearing surface so the sill pan or sill can be properly caulked and sealed to the opening. Scrape sand or fill as required.

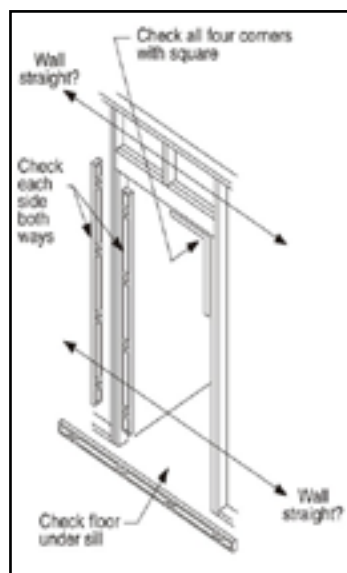

NOTE: If additional floor covering clearance is required, attach the shim board to the subfloor. Be sure to caulk well under the shim board.

Is the opening square? Check all corners with a framing square. Double check by comparing diagonal measurements. Fix any problems now.

Check to be sure the framing walls around the opening are in the same plane. Do this by performing a "string test" for plumb.

2 CHECK & PREPARE THE OPENING (CONT...)

String Test for Plumb: Attach a string diagonally across the opening from the outside, as shown. The string(s) should gently touch in the center, if not the opening is "out of plumb" by twice that distance and needs to be corrected. Flip the string over itself to check both planes. Fix any problems now. An "out of plumb" condition is one of the most common reasons door units leak air and water.

3 PREPARE THE OPENING

On the subfloor at opening, place three very large beads of sealant. Run the beads the full width of the opening.

Use only elastomeric or polyurethane sealant.

Use an entire tube when caulking along the subfloor.

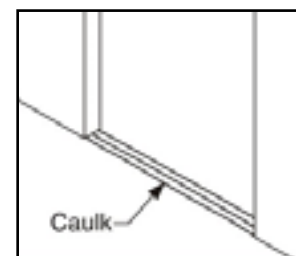

3A INSTALLATION WITH A SILL PAN

Place the right and left sill pan ends onto the caulk beads and tightly against the side of the opening.

Then, liberally coat the overlapped areas and the recessed areas of the pieces with the PVC cement provided. Place center section(s) in position and hold pieces together long enough to ensure a good bond.

For added protection, spread a bead of caulk along the glue joints and to prevent air infiltration, run a bead of caulk along the lower interior edge of the sill pan. Additional caulking could affect the performance of the sill pan.

DO NOT caulk the bottom of the sill when using a sill pan.

3B INSTALLATION WITHOUT A SILL PAN

Lay the door unit on edge or face so that the bottom surface of the sill can be caulked. Place very large beads of caulk across the full width of the sill. Additionally, place beads of caulk along the junction of the sill and the jamb and on the bottom surface of the jambs and brickmould.

3B INSTALLATION WITHOUT A SILL PAN (CONT...)

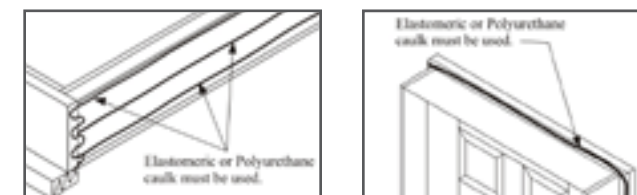

NOTE: If a sill extender is used, place a large bead of caulk at the junction of the extender and the sill approach.

IMPORTANT! Apply sealant to the back side of brickmould around the entire perimeter of the door unit. A 1/2 - 5/8 inch bead of elastomeric or polyurethane caulk is essential.

4 TEMPORARILY FASTEN UNIT IN OPENING

Lift the unit up. With top edge tilted away from opening, center the unit and place sill down onto sill pan (or caulk beads), and tilt into the opening.

For all door unit configurations, note the hinge locations and mark those locations on the jamb faces near the door surfaces. Pre-drill 1/8 inch diameter holes at these locations for screw placement. A counter sink bit will help to conceal the screw heads.

Install screws in the center pre-drilled hole locations on both jambs to temporarily secure the unit in the place. Do not drive screws completely in at this time. Use #8 x 2-1/2 inch or 3 inch exterior grade screws.

DO NOT fasten through the brickmould.

Work from the side of the door that is weather-stripped.

Use a 6-foot level, and plumb the hinge side jamb both ways (right to left and inside to outside).

Place screws through the hinge side jamb into the studs, at each remaining hinge location, as shown in the diagrams. Use #8 X 2-1/2 inch or 3 inch exterior grade screws.

DO NOT drive the screws completely in at this time.

For single or double doors, place screws at each hinge location, so shims can be placed behind hinges above screws. The screws will keep the shims from falling down while adjustments are being made.

4 TEMPORARILY FASTEN UNIT IN OPENING (CONT...)

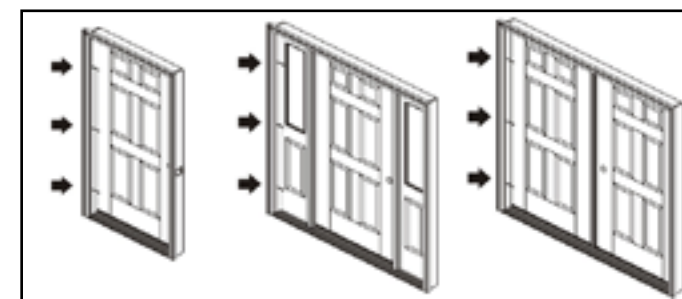

For sidelite units, fasten the jamb on the hinge side of the door.

For double door and patio units, fasten the fixed or passive side of the unit first.

5 SHIM AT HINGE LOCATIONS & SECURE HINGE JAMB

Leave door fastened and closed with the transport clip.

Shim above the screws, behind each hinge location, and between the opening and the jamb.

Use a 6-foot level, and re-check hinge jamb to ensure it is plumb and straight.

Finish driving screws tight in the middle first, then top and bottom last.

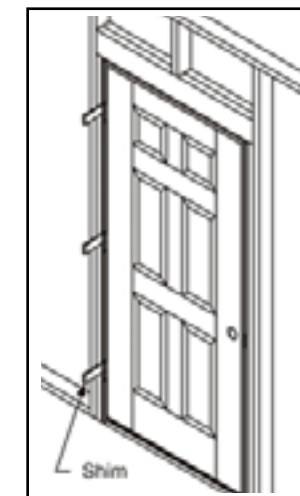

6 ADJUST REST OF FRAME & FASTEN

From the weatherstrip side of the door, check weatherstrip margins and contact.

Make frame adjustments so the weatherstrip contacts the door surface equally at the top, middle and bottom, an even 3/8 inch to 1/2 inch when fully closed.

Secure the lock side jamb with #8 X 2-1/2 or 3 inch screws through the pre-drilled holes at the top and bottom.

DO NOT drive screws tight at this time.