

# DuPont™ Tyvek® Water-Resistive and Air Barriers (WRB) and DuPont Self-Adhered Flashing Products Installation Guidelines

Windows and Doors Installed  
**BEFORE** the Tyvek® WRB



For Single-Family Residential Buildings



September 2021

## Table of Contents

|  |     |  |     |
|--|-----|--|-----|
| Introduction.....  | 3   | <b>DuPont™ Tyvek® WRB</b> Installation Instructions (Windows/Doors Installed<br><b>BEFORE</b> the Tyvek® WRB)..... | 117 |
| Applicable Products.....   | 3   | Key Installation Requirements for <b>DuPont™ Tyvek® WRBs</b> .....   | 117 |
| Additional Materials Based on Project Requirements, Details, and Specifications.....   | 4   | Temporary Fastening.....   | 118 |
| Warranty.....  | 4   | Alternate Fastening.....   | 118 |
| Applicable Structures and Performance Criteria.....  | 5   | Installation Method for New Construction.....  | 119 |
| Water-Resistive Barrier (WRB) Code Requirements.....   | 7   | DuPont Self-Adhered Flashing Products Integration.....   | 121 |
| Flashing Products Code Requirements.....   | 7   | Continuity.....  | 123 |
| Additional Codes and Standards Information for<br>DuPont™ Tyvek® Commercial Air and Water Barrier Systems.....                       | 8   | Penetrations.....  | 129 |
| General Instructions.....  | 8   | Flashing Beam Penetrations.....  | 133 |
| Special Considerations.....  | 8   | Handling Tears and Holes.....  | 134 |
| Installation Methods for <b>DuPont Self-Adhered Flashing Products</b> Installed<br><b>BEFORE</b> the <b>DuPont™ Tyvek® WRB</b> ..... | 11  | Tilt Wall Instructions.....  | 135 |
| Key Installation Requirements for Drainable Window/Door Installation.....  | 11  | Façade Considerations.....   | 136 |
| Integral Flanged Window.....   | 12  | Product Composition and UV Stability.....  | 139 |
| Integral Flanged Adjacent Rectangular Windows (with Less Than 6” of Sheathing/<br>Framing Between Windows).....                      | 17  | Design Considerations.....   | 139 |
| Integral Flanged Door.....   | 35  | Safety and Handling.....   | 139 |
| Drip Cap Installation with Integral Flanged Windows and Doors.....   | 42  | Hazard Statement.....  | 140 |
| Non-Flanged Windows and Doors (Using “Wrap the Cavity” Method).....  | 47  | For More Information.....  | 140 |
| Non-Flanged Window Using <b>DuPont™ VersaFlange™</b> .....   | 52  |  |     |
| Non-Flanged Door Using <b>DuPont™ VersaFlange™</b> .....   | 60  |  |     |
| Field Applied Flanged Window.....  | 69  |  |     |
| Field Applied Flanged Door.....  | 77  |  |     |
| Brick Mold Window.....   | 87  |  |     |
| Brick Mold Door.....   | 94  |  |     |
| Integral Flanged Window – “Pre-Strip” Methods.....   | 103 |  |     |



## Introduction

This Installation Guideline pertains to single-family residential buildings. See [Applicable Structures and Performance Criteria](#) for more information regarding building types and building envelope performance.

This Installation Guideline outlines recommended installation techniques and details for **DuPont Self-Adhered Flashing Products** installed **BEFORE DuPont™ Tyvek® Water Resistive and Air Barriers**, referred to in this document as **DuPont™ Tyvek® WRBs**. This includes **DuPont™ Tyvek® HomeWrap®**, **Tyvek® StuccoWrap®**, **Tyvek® DrainWrap™**, **Tyvek® ThermaWrap® LE**, **Tyvek® CommercialWrap®** and/or **Tyvek® CommercialWrap® D**. Where applicable, **DuPont™ Tyvek® Fluid Applied Products** are shown installed in conjunction with **Tyvek® WRBs** in hybrid conditions. Both **Tyvek® WRBs** and **Tyvek® Fluid Applied Products** meet or exceed the requirements of a water-resistive barrier as defined in the 2018 International Residential Code (IRC) and 2018 International Building Code (IBC).

Always check [building.dupont.com](http://building.dupont.com) for the latest versions of DuPont Installation Guidelines and other product literature.

## Applicable Products

### Water-Resistive and Air Barriers (Tyvek® WRBs)

| Product                                 | Dimensions                       | Area                       |
|---|----------------------------------|----------------------------|
| <b>DuPont™ Tyvek® HomeWrap®</b>         | 3 ft x 100 ft                    | 300 sq ft                  |
|   | 3 ft x 165 ft                    | 495 sq ft                  |
|   | 5 ft x 200 ft                    | 1,000 sq ft                |
|   | 9 ft x 100 ft                    | 900 sq ft                  |
|   | 9 ft x 150 ft                    | 1,350 sq ft                |
|   | 10 ft x 100 ft<br>10 ft x 150 ft | 1,000 sq ft<br>1,500 sq ft |
| <b>DuPont™ Tyvek® StuccoWrap®</b>       | 5 ft x 200 ft                    | 1,000 sq ft                |
| <b>DuPont™ Tyvek® DrainWrap™</b>        | 9 ft x 125 ft                    | 1,125 sq ft                |
|   | 10 ft x 125 ft                   | 1,250 sq ft                |
| <b>DuPont™ Tyvek® ThermaWrap® LE</b>    | 5 ft x 150 ft                    | 750 sq ft                  |
|   | 9 ft x 100 ft                    | 900 sq ft                  |
| <b>DuPont™ Tyvek® CommercialWrap®</b>   | 5 ft x 200 ft                    | 1,000 sq ft                |
|   | 10 ft x 125 ft                   | 1,250 sq ft                |
| <b>DuPont™ Tyvek® CommercialWrap® D</b> | 5 ft x 200 ft                    | 1,000 sq ft                |
|   | 10 ft x 125 ft                   | 1,250 sq ft                |

### Fluid Applied Products

| Product  | Quantity       |
|--|----------------|
| <b>DuPont™ Tyvek® Fluid Applied WB+™</b>                         | 5 gal, 50 gal  |
| <b>DuPont™ Tyvek® Fluid Applied Flashing and Joint Compound+</b> | 28 oz, 3.5 gal |
| <b>DuPont™ Sealant for Tyvek® Fluid Applied System*</b>          | 28 oz          |

\*DuPont™ Sealant for Tyvek® Fluid Applied System should only be used as directed in the applicable DuPont™ Tyvek® Fluid Applied Products Installation Guidelines.

### Self-Adhered Flashing Products

| Product  | Width   |
|--|---------|
| <b>DuPont™ FlexWrap™ EZ</b>                                      | 2.75 in |
| <b>DuPont™ FlexWrap™</b> (Formerly DuPont™ FlexWrap™ NF)         | 6 in    |
|  | 9 in    |
| <b>DuPont™ StraightFlash™</b>                                    | 4 in    |
|  | 9 in    |
| <b>DuPont™ VersaFlange™</b> (Formerly DuPont™ StraightFlash™ VF) | 6 in    |
| <b>DuPont™ Flashing Tape</b>                                     | 4 in    |
|  | 6 in    |
|  | 9 in    |
|  | 12 in   |

### Installation Accessories

| Product   | Type  | Quantity          |
|---|---|-------------------|
| <b>DuPont™ Tyvek® Tape</b>  | 2 in Bulk Pack                                | 6 rolls/bulk pack |
|   | 3 in Bulk Pack                                |                   |
| <b>DuPont™ Tyvek® Metallized Tape</b>   | 2 in x 100 ft Rolls                           | 12 rolls/case     |
| <b>DuPont™ Tyvek® Wrap Cap Staples</b> or other cap staples for Stinger® Cap Stapler                                  | 7/8 in, 1-1/4 in, and 1-1/2 in lengths        | 2,000/box         |
|   | 3/8 in and 5/8 in lengths                     | 2,016/box         |
| <b>DuPont™ Tyvek® Wrap Cap Nails</b>  | 1 in electro-galvanized ring shank nail       | 2,000/box         |
| <b>DuPont™ Tyvek® Wrap Cap Screws</b>   | 2 in dia. plastic cap, 1-3/4 in screw length  | 1,000/box         |
| <b>Great Stuff Pro™ Window &amp; Door Polyurethane Foam Sealant</b>   | Can (reusable dispensing gun sold separately) | 20 oz             |
| <b>Great Stuff Pro™ Gaps &amp; Cracks Polyurethane Foam Sealant</b>   | Can (reusable dispensing gun sold separately) | 20 oz             |
| <b>DuPont™ RainVent™ Battens</b>  | 5/8 in x 3/8 in x 8 ft                        | 40/pack           |
| <b>DuPont™ Tyvek® DrainVent™ Rainscreen</b>   | 4 ft x 50 ft roll                             |                   |
| Tower® Residential Sealant (formerly DuPont™ Residential Sealant)   |   |                   |
| TRUFAST® Walls Grip-Deck® screws with Thermal-Grip FastCap™ washers (TRUFAST® Walls formerly Rodenhouse) <sup>1</sup> |   |                   |

<sup>1</sup>For information regarding installation of TRUFAST® Walls fasteners, refer to the [Key Installation Requirements for DuPont™ Tyvek® WRBs](#) section of this document.

## Additional Materials Based on Project Requirements, Details, and Specifications<sup>1</sup>

- Backer Rod
- Sealant<sup>2</sup>
- Adhesive/Primer<sup>2</sup>
- Brushes for Surface Preparation
- J-Roller
- Trowels

<sup>1</sup>Apply per manufacturers' guidelines. **For non DuPont products, DuPont assumes no liability in use of recommended products** — installers need to evaluate suitability of recommended products in their end-use applications.

<sup>2</sup>For information regarding chemical compatibility of sealants, see technical bulletin [Chemical Compatibility of Representative Building Sealants and Adhesives/Primers](#).

## Warranty

Please refer to the [DuPont Building Envelope Solutions Products 10-Year Limited Warranty for Single-Family, Wood-Framed Multi-Family, and Light Commercial Buildings](#).

**NOTE:** In order to make a claim under the DuPont Performance Building Solutions 10-Year Limited Product and Labor Warranty, you must have met all of the terms and conditions of the warranty, including use of the applicable DuPont Installation Guidelines available at the date of original installation. In the event that a specific detail or installation technique is not covered in the DuPont Installation Guidelines at the time of construction, then the *Key Installation Requirements* outlined in this document must have been followed in order to make a claim under the warranty. It is in the sole discretion of DuPont to determine if full compliance with the *Key Installation Requirements* exists. Please contact DuPont or a DuPont Representative if you have any questions regarding any DuPont Installation Guideline.



## Applicable Structures and Performance Criteria

### Applicable Structures

**These Installation Guidelines pertain solely to single-family residential buildings as defined below.**

DuPont categorizes structures into three primary groups:

- i.) **“Single-Family Residential Buildings”** are defined as fully-detached one or two family structures, as well as townhouse structures not more than three stories above grade plane as defined in the 2018 International Residential Code (IRC) Section R101.2, both to the extent they are exclusively Residential Use building structures.
- ii.) **“Wood-Framed Multi-Family and Light Commercial Buildings”** are defined by DuPont as the following (must meet **ALL** criteria):
  - a. Constructed of wood-based structural exterior framing of Type III or Type V Construction\* (IBC Chapter 6); and
  - b. Does not exceed 2018 IBC max height (Table 504.3) for Type V construction (70 ft.) or Type III construction (85 ft.), including allowances for Automatic Sprinkler height increase (IBC 504.1 and Table 504.4) and ‘podium’ structures outlined in the Special Provisions\* (IBC Section 510); and
  - c. Design requirements for the building envelope do not exceed air barrier performance of ASTM E1677 (10.8 psf structural load, 65 mph equivalent wind load), and water infiltration resistance criteria of 6.24 psf (50 mph equivalent wind-driven rain) when tested in accordance with ASTM E331, ASTM E1105, or equivalent.

\*Special Provisions (IBC Section 510) allows for a “horizontal building separation”, or ‘podium’, to be built under the wood-framed Type III or Type V building. The podium is typically constructed of steel framing or concrete. Podium-style buildings are included under “Wood-Framed Multi-Family and Light Commercial Buildings”, as long as all other definition criteria (a. through c. above) are met.

- iii.) **“Commercial and High-Performance Buildings of Any Height”** are defined by DuPont as any of the following:
  - a. Structures constructed of steel-based structural exterior framing and any exterior sheathing, or
  - b. Structures with exterior above grade walls constructed of concrete or concrete masonry units (CMU), or
  - c. Structures of any height and construction type (including any framing type) that are designated as high-performance. “High-performance” is defined as air barrier performance exceeding ASTM E1677 and/or water infiltration resistance criteria exceeding 6.24 psf when tested in accordance with ASTM E331, ASTM E1105, or equivalent.

**NOTE:** “Podium” style structures with wood-framed floors built above steel-framed or concrete/CMU floors are covered under “Wood-Framed Multi-Family and Light Commercial Buildings” unless they are “high-performance”.

### Water-Resistive Barrier Performance Requirements

These Installation Guidelines pertain to single-family residential buildings with air and water barrier performance not exceeding ASTM E1677 (10.8 psf structural load, 65 mph equivalent wind load), and water infiltration resistance criteria not exceeding 0.56 psf (15 mph equivalent wind-driven rain).

## Applicable Structures and Performance Criteria

### DuPont Building Envelope Solutions Products Installation Considerations for Single-Family Residential Buildings

These Installation Guidelines should be used for buildings which meet the applicable structures definitions and performance criteria on the previous page. The following table provides a summary of typical installation information. For more information, please see the respective section in this document.

| Installation Considerations                                  | Non-Air Barrier Installations (water details only)  | Air Barrier Installations   |
|--|---|---|
| <b>Tyvek® WRB</b>  | <b>DuPont™ Tyvek® HomeWrap®, Tyvek® DrainWrap™, Tyvek® StuccoWrap®, Tyvek® CommercialWrap®, Tyvek® CommercialWrap® D</b>  |   |
| <b>DuPont™ Tyvek® Fluid Applied Products</b>                 | Can be used on any above grade exterior wall where specified in hybrid details in this guide. Recommended for use on above grade exterior CMU and/or concrete walls. Refer to the Installations Guidelines for <a href="#">DuPont™ Tyvek® Fluid Applied Flashing</a> and/or <a href="#">Tyvek® Fluid Applied WB+™</a> for additional information. |   |
| <b>DuPont™ Tyvek® Tape</b>                                   | 2" (3" required when using <b>Tyvek® DrainWrap™</b> , <b>Tyvek® StuccoWrap®</b> , or <b>Tyvek® CommercialWrap® D</b> )  |   |
| <b>Typical Recommended Fasteners and Spacing<sup>1</sup></b> | 1" <b>DuPont™ Tyvek® Wrap Cap Staples or Nails</b> (or equivalent) fastened along stud lines spaced at 6"– 18" vertically   |   |
| <b>Tyvek® WRB Top of Wall Termination</b>                    | Skip-sealing along top of wall using Tower® Residential Sealant or <b>Tyvek® Tape</b>   | Full seal along top of wall using Tower® Residential Sealant or <b>Tyvek® Tape</b> .    |
| <b>Tyvek® WRB Bottom of Wall Termination</b>                 | Skip-sealing along bottom of wall using Tower® Residential Sealant or <b>Tyvek® Tape</b>  | Full seal along bottom of wall using Tower® Residential Sealant or <b>Tyvek® Tape</b> . |
| <b>Recommended Window/Door Head Flap Treatment</b>           | Skip-sealing along horizontal edge using <b>Tyvek® Tape</b> is acceptable   | Full seal along horizontal edge and 45° cuts using <b>Tyvek® Tape</b> .                 |

<sup>1</sup>For increased holding power and for higher air and water holdout performance, DuPont recommends fasteners of sufficient length to penetrate securely into the stud. Temporary Fastening methods can be used. See [Temporary Fastening](#) section for more information.

## Water-Resistive Barrier (WRB) Code Requirements

The 2018 International Residential Code (Section R703.1.1 Water Resistance) requires that “the exterior wall envelope shall be designed and constructed in a manner that prevents the accumulation of water within the wall assembly by providing a water-resistant barrier behind the exterior cladding as required by Section R703.2 and a means of draining to the exterior water that penetrates the exterior cladding.” Section R703.2 (Water-resistive barrier) states that “one layer of No. 15 asphalt felt, free from holes and breaks, complying with ASTM D 226 for Type 1 felt or other approved water-resistive barrier shall be applied over studs or sheathing of all exterior walls. No. 15 asphalt felt shall be applied horizontally, with the upper layer lapped over the lower layer not less than 2 inches (51 mm). Where joints occur, felt shall be lapped not less than 6 inches (152 mm). Other approved materials shall be installed in accordance with the water-resistive barrier manufacturer’s installation instructions. The No. 15 asphalt felt or other approved water-resistive barrier shall be continuous to the top of walls and terminated at penetrations and building appendages in a manner to meet the requirements of the exterior wall envelope as described in Section R703.1.”

The **DuPont™ Tyvek® WRBs** listed below qualify as approved water-resistive barriers based on ICC-ES AC38 Acceptance Criteria according to the associated Evaluation Reports:

- ICC-ES Evaluation Report ESR 2375
  - **DuPont™ Tyvek® HomeWrap®**
  - **DuPont™ Tyvek® StuccoWrap®**
  - **DuPont™ Tyvek® DrainWrap™**
  - **DuPont™ Tyvek® CommercialWrap®**
  - **DuPont™ Tyvek® CommercialWrap® D**
- ICC-ESR-1993: **DuPont™ Tyvek® ThermaWrap® LE**

**DuPont™ Tyvek® Fluid Applied WB+™** meets ICC-ES AC212, *Acceptance Criteria for Water-Resistive Coatings Used as Water-Resistive Barriers Over Exterior Sheathing*, per the following:

- Intertek Code Report: CCRR-0307 for **Tyvek® Fluid Applied WB+™**

Air leakage control and air barriers are required for the building thermal envelope per the 2018 International Energy Conservation Code – Residential Provisions (IECC-R), Section R402.4, which requires that air leakage is limited in accordance with Sections R402.4.1 through R402.4.5.

Section R402.4.1 provides requirements for air barrier and insulation installation as well as requirements for testing the building envelope air leakage after installation, such as blower door testing. When installed following the air barrier details in this DuPont Installation Guideline, **Tyvek® WRBs** can help meet the air barrier requirements in Section R402.4.1.

All **Tyvek® WRBs** have been tested to the following standards:

- ASTM E2556 *Type II Standard Specification for Vapor Permeable Flexible Sheet Water-Resistive Barriers Intended for Mechanical Attachment*
- ASTM E1677 *Standard Specification for an Air Retarder (AR) Material or System for Low-Rise Framed Building Walls*
- ASTM E2178 *Standard Test Method for Air Permeance of Building Materials*
- ASTM E96 *Standard Test Methods for Water Vapor Transmission of Materials*

- AATCC 127 *Test Method for Water Resistance: Hydrostatic Pressure*
- ASTM E84 *Standard Test Method for Surface Burning Characteristics of Building Materials*
- ASTM E2273 *Standard Test Method for Determining the Drainage Efficiency of Exterior Insulation and Finish Systems (EIFS) Clad Wall Assemblies* (excludes **Tyvek® ThermaWrap® LE** and **Tyvek® Fluid Applied WB+™**)

The application of **Tyvek® WRBs** is governed by the code adopted and enforced by the local jurisdiction. Consult your jurisdiction to assure compliance with the local building code.

## Flashing Products Code Requirements

The 2018 International Residential Code (Section R703.4 Flashing) requires that “approved corrosion-resistant flashing shall be applied shingle-fashion in a manner to prevent entry of water into the wall cavity or penetration of water to the building structural framing components. Self-adhered membrane used as flashing shall comply with AAMA 711. Fluid-applied membranes used as flashing in exterior walls shall comply with AAMA 714. The flashing shall extend to the surface of the exterior wall finish. Approved corrosion-resistant flashings shall be installed at the following locations: (1) Exterior window and door openings. Flashing at exterior window and door openings shall extend to the surface of the exterior wall finish or to the water-resistive barrier complying with Section 703.2 for subsequent drainage. Mechanically attached flexible flashing shall comply with AAMA 712. Flashing at exterior window and door openings shall be installed in accordance with one or more of the following: 1.1 The fenestration manufacturer’s installation and flashing instructions, or for applications not addressed in the fenestrations manufacturer’s instructions, in accordance with the flashing manufacturer’s instructions. Where flashing instructions or details are not provided, pan flashing shall be installed at the sill of exterior window and door openings. Pan flashing shall be sealed or sloped in such a manner as to direct water to the surface of the exterior wall finish or to the water-resistive barrier for subsequent drainage. Openings using pan flashing shall incorporate flashing or protection at the head and sides. 1.2 In accordance with the flashing design or method of a registered design professional. 1.3 In accordance with other approved methods. (2) At the intersections of chimneys or other masonry construction with frame or stucco walls, with projecting lips on both sides under stucco copings. (3) Under and at the ends of masonry, wood or metal copings and sills (4) Continuously above all projecting wood trim. (5) Where exterior porches, decks or stairs attach to a wall or floor assembly of wood-frame constructions. (6) At wall and roof intersections. (7) At built-in gutters.

- **DuPont Self-Adhered Flashing Products** comply with AAMA 711-13 (an FGIA Specification) *Specification for Self Adhering Flashing Used for Installation of Exterior Wall Fenestration Products*.
- **DuPont™ Tyvek® Fluid Applied Flashing and Joint Compound+** complies with AAMA 714-15, *Voluntary Specification for Liquid Applied Flashing Used to Create a Water-Resistive Seal around Exterior Wall*.



## Additional Codes and Standards Information for DuPont™ Tyvek® Commercial Air and Water Barrier Systems

DuPont™ Tyvek® CommercialWrap®, Tyvek® CommercialWrap® D, DuPont™ StraightFlash™, DuPont™ FlexWrap™, and DuPont™ Tyvek® Fluid Applied Products were designed for the rigors of heavy commercial construction. These commercial products have been tested to the following standards:

- ABAA Evaluated
- ASTM E2357 *Standard Test Method for Determining Air Leakage of Air Barrier Assemblies*
- ASTM E331 *Standard Test Method for Water Penetration of Exterior Windows, Skylights, Doors, and Curtain Walls by Uniform Static Pressure*
- ASTM E1105 *Standard Test Method for Field Determination of Water Penetration of Installed Exterior Windows, Skylights, Door, and Curtain Walls, by Uniform or Cyclic Static Air Pressure Difference*
- ASTM E283 *Standard Test Method for Determining Rate of Air Leakage Through Exterior Windows, Curtain Walls and Doors Under Specified Pressure Differences Across the Specimen*
- AAMA 501.5 *Test Method for Thermal Cycling of Exterior Walls*
- NFPA 285 *Standard Fire Test Method for Evaluation of Fire Propagation Characteristics of Exterior Non-Load-Bearing Wall Assemblies Containing Combustible Components*

Energy Conservation Codes for commercial buildings are being adopted in many regions across the U.S. DuPont™ Tyvek® Water-Resistive and Air Barriers (WRBs) currently meet the following codes and guidelines.

- ASHRAE 90.1 Model Energy Code air barrier requirements
- 2018 International Energy Conservation Code® (IECC)
- 2018 International Green Construction Code™ (IgCC)

## General Instructions

The best time to install Tyvek® WRBs is:

- **AFTER** the roof sheathing is installed
- **AFTER** the step, kickout, and through-wall flashings have been installed.

**DuPont Self-Adhered Flashing Products are not intended for through-wall flashing applications.**

## Special Considerations

1. These Installation Guidelines, including the allowable use of DuPont Products, are based on building air and water barrier performance not exceeding ASTM E1677.
2. **DuPont Self-Adhered Flashing Products** should be installed on clean, dry surfaces that are free of frost. Wipe surfaces to remove moisture, dirt, grease and other debris that could interfere with adhesion.
3. **DuPont Self-Adhered Flashing Products** perform best when installed at temperatures above 25°F (-4°C).
4. Adverse weather conditions or cold temperatures may require use of an adhesive/primer to promote adhesion of **DuPont Self-Adhered Flashing Products** to most common building materials. **Concrete, masonry, and fiber-faced exterior gypsum board require the use of a recommended adhesive/primer.** Do not apply adhesive/primer, to exterior continuous insulation due to potential sheathing degradation.
5. Remove all wrinkles and bubbles that may allow for water intrusion by smoothing surface and repositioning as necessary during installation of **DuPont Self-Adhered Flashing Products**. Apply pressure along entire surface of flashing for a good bond using firm hand pressure, J-roller, or alternate tool without sharp edges (such as a plastic carpet tuck tool) to assist with application of uniform pressure.
6. **DuPont Self-Adhered Flashing Products** are not intended for through-wall flashing applications.
7. When using mechanically fastened through-wall flashing, DuPont recommends sealing top edge with **DuPont™ Flashing Tape** or **StraightFlash™**.
8. When flashing the sill area for windows and doors, DuPont recommends the use of 6" wide **FlexWrap™** for 2"x 4" framing and 9" wide **FlexWrap™** for 2" x 6" framing. When rigid back dams are required or desired, an option would be to use a 3/4" corner guard (back dam) cut to the length of the sill and nail into place on the interior edge of the sill prior to installation of 9" wide **FlexWrap™**. Then install 9" wide **FlexWrap™** over sill and corner guard back dam.
9. **Do Not Stretch FlexWrap™** when installing along sills or jambs. **FlexWrap™** is only intended to be stretched when covering corners or curved sections.
10. When installing **DuPont™ FlexWrap™ EZ** and **FlexWrap™** on penetrations or other wall conditions, ensure the flashing will not be exposed after completion of cladding.

## Special Considerations

11. **DuPont Self-Adhered Flashing Products** can be used to bridge non-movement gaps up to 1/4" unsupported. Flashing must maintain a 2" adhesive lap on the wall substrate.
12. **Do Not Apply DuPont™ Tyvek® Tape** or **DuPont Self-Adhered Flashing Products** over **DuPont™ Tyvek® Wrap Cap Fasteners**, or recommended fasteners however, fasteners can be installed over the flashing.
13. When installing the **DuPont™ Tyvek® WRB**, **do not install** fasteners within 6" of the sills and jambs of the openings and within 9" of the head of the openings.
14. **Great Stuff Pro™ Window and Door Polyurethane Foam Sealant** can be used in lieu of sealant to create a continuous seal around the interior perimeter of the window openings. When using **Great Stuff Pro™ Window and Door Polyurethane Foam Sealant** in perimeter openings less than 1/2", apply using the plastic extension tip for the **Great Stuff™ Dispenser Gun** during installation.
15. For extreme/coastal exposures, installation of a high-pressure skirt is recommended to help prevent water intrusion at the sill or threshold.
16. For additional wind load resistance, the use of **DuPont™ Flashing Tape** or **DuPont™ StraightFlash™** with **Tyvek® Wrap Cap Fasteners**, or recommended fasteners can be installed to secure the head flap of the windows.
17. **Tyvek® Tape** can be used as indicated in this Installation Guideline to seal the **Tyvek® WRB** to most plastic top sheets of self-adhered products and to thin metal flashings (e.g. drip caps or through wall kick-out flashings). **Tyvek® Tape** should **NOT** be used to seal **Tyvek® WRBs** to wood framing/sheathing, exterior gypsum sheathing, or masonry.
18. **Tyvek® Tape** is a seam tape primarily designed to seal **Tyvek® WRB** seams. **Tyvek® Tape** is **NOT** a flashing product, and should not be used in applications where a flashing product is required.
19. Before applying **Tyvek® Tape**, surfaces should be dry and clean. During installation apply firm, even pressure with hand or "J" roller.
20. In lieu of temporarily taping, **Tyvek® WRB** flaps at window head and jambs can be tucked under the installed **Tyvek® WRB**.
21. Door and window rough sill framing must be level or slightly sloped to the exterior to ensure proper drainage to the exterior. This best practice ensures continuous support with positive slope to the exterior.
22. For window or door openings greater than 6 feet wide, **DuPont™ Flashing Tape** or **StraightFlash™** can be used with **DuPont™ FlexWrap™** in 3-piece sill/head applications. **DuPont™ Flashing Tape** or **StraightFlash™** should be applied the length of the sill prior to placing the **FlexWrap™** corners. The **FlexWrap™** corners should be at least 12" long allowing for 6" up the jamb and 6" of overlap on the **FlexWrap™** sill flashing. When applying the 3-piece flashing detail to the head of the opening, the **DuPont™ Flashing Tape** or **StraightFlash™** head piece should be applied prior to installing the **FlexWrap™** corner flashing. Minimum overlapping of the **FlexWrap™** head flashing and jamb flashing should be a minimum of 6".
- Registered DuPont Certified Installers may use the 3-piece sill/head flashing method on window and door openings of any size. Please contact your local Building Envelope Specialist for additional information.
23. **DuPont™ Tyvek® DrainWrap™**, **Tyvek® StuccoWrap®**, and **Tyvek® CommercialWrap® D** must be installed with the grooves going up and down.
24. **DuPont™ Tyvek® HomeWrap®** and **Tyvek® CommercialWrap®** provide >90% drainage efficiency, and **Tyvek® DrainWrap™**, **Tyvek® StuccoWrap®**, and **Tyvek® CommercialWrap® D** provide >98% drainage efficiency when tested in accordance with ASTM E2273.
25. When installing **Tyvek® WRBs** at *interior insulation dams*, (e.g. knee walls), or as an *interior air barrier*, please consult the appropriate Air Barrier Installation Detail available at [building.dupont.com](http://building.dupont.com).
26. No surface preparation is needed for the installation of **Tyvek® WRBs**.
27. Suitable substrates for **DuPont™ Tyvek® Fluid Applied Products** include concrete masonry unit (CMU), concrete (48 hrs. cure for green concrete), exterior gypsum, OSB, plywood, wood, and metal. Contact your local DuPont Representative for use with pressure treated or fire retardant treated wood (FRT).
28. DuPont recommends the use of the **DuPont™ Tyvek® Fluid Applied Air Barrier System** for CMU walls with embedded brick ties. Please refer to the [DuPont® Tyvek® Fluid Applied WB+™ Wall and Substrate Guidelines](#) for specific installation instructions.
29. **Tyvek® Fluid Applied Products** should only be used for wall systems that include a continuous path for drainage allowing moisture that penetrates the facade to exit to the exterior. The drainage path should be continuous throughout the wall assembly, including but not limited to areas such as eyebrows, band boards, penetrations, or other locations where transitions and changes of plane occur. For membrane drainage wall systems, ensure that the drainage path is not blocked or disrupted to prevent excess moisture buildup in the wall cavity.
30. When **Tyvek® Fluid Applied Products** are used as the air and water barrier, **Tyvek® WRBs** may be installed as an "intervening layer" over **Tyvek® Fluid Applied Products** after 48 hours of curing at 70°F (20°C) and 50% RH. For additional information about the use of "intervening layers" see the Stucco section under [Facade Considerations](#).
31. Uncured **Tyvek® Fluid Applied Products** must not come in contact with building wraps due to potential impact on performance properties.
32. **Tyvek® CommercialWrap®** and **Tyvek® CommercialWrap® D** may be installed over **Tyvek® Fluid Applied Products** after 48 hours of curing at 70°F (20°C) and 50% RH.
33. **Tyvek® HomeWrap®**, **Tyvek® StuccoWrap®**, and/or **Tyvek® DrainWrap™** should not come in direct contact with cured or uncured **Tyvek® Fluid Applied Products**.
34. **Tyvek® WRBs** and **Tyvek® Fluid Applied Products** can be applied to damp surfaces. A surface is considered damp if there is no visible water on the surface and no transfer of water to the skin when touched.
35. **DuPont™ Tyvek® Fluid Applied Flashing and Joint Compound+** can be troweled or brushed to the required thickness in any application outlined in the guide.

## Special Considerations

36. **DuPont™ Tyvek® Fluid Applied Products** should be applied when air and surface temperatures are above 25°F. Do not install once the ambient temperature exceeds 95°F (35°C), unless the application surface is shaded. The maximum surface temperature for application is 140°F (60°C).
37. **Tyvek® Fluid Applied Products** may be overcoated once a tack-free skin has formed. Exterior insulation and/or exterior facade may be installed after **Tyvek® Fluid Applied Products** have cured for 48 hours. Please refer to *Drying/Curing* information in the [DuPont™ Tyvek® Fluid Applied WB+™ Wall and Substrate Guidelines](#).
38. Performance testing, included but not limited to peel adhesion, pull strength analysis, field or third-party testing of air and/or water barrier properties, should be conducted after **Tyvek® Fluid Applied Products** are fully cured (~14 days).
39. **DuPont™ Tyvek® WRBs** must not come in direct contact with other manufacturers' cured or uncured fluid-applied and/or deck coating waterproofing products due to potential impact on performance properties. **DuPont™ StraightFlash™** can be used as transitional membrane.
40. DuPont requires **DuPont™ Tyvek® HomeWrap®**, **Tyvek® StuccoWrap®**, and **Tyvek® DrainWrap™** be covered within 4 months (120 days) of installation. DuPont requires **DuPont™ Tyvek® CommercialWrap®** and **Tyvek® CommercialWrap® D** and **Tyvek® Fluid Applied Products** be covered within 9 months (270 days) of installation.
41. DuPont requires that **DuPont™ FlexWrap™**, **FlexWrap™ EZ**, **StraightFlash™**, and **DuPont™ VersaFlange™** be covered within 9 months (270 days) of installation. DuPont requires that **DuPont™ Flashing Tape** be covered within four months (120 days) of installation.
42. DuPont requires all of its synthetic roofing underlayments to lap onto walls a minimum of 8". For more information related to **DuPont™ Tyvek® Roof Protector™** and **Tyvek® Protec™ Roofing Underlayments** please visit [building.dupont.com](#), or consult your local DuPont Representative
43. The maximum in-service temperature for **Tyvek® WRBs**, **DuPont Self-Adhered Flashing Products**, and **Tyvek® Fluid Applied Products** is 180°F.
44. Tower® Residential Sealant (formerly DuPont™ Residential Sealant) is designed for use with DuPont products and can be used where sealant is outlined in this guide. This change represents a branding change only—chemical composition and performance characteristics of the sealant are unchanged.
45. For details regarding flashing garage door openings, refer to [Installation Instructions for Garage Doors Installed AFTER the DuPont™ Tyvek® Water-Resistive and Air Barrier \(WRB\) is Installed](#).
46. When applying Tower® Residential Sealant, or recommended sealant, during window installation, DuPont recommends minimizing or removing excess sealant that may interfere with adhesion of **DuPont Self-Adhered Flashing Products**.

For additional guidance, please call 1-833-338-7668, visit our website at [building.dupont.com](#), or consult your local DuPont Representative.



## Installation Methods for DuPont Self-Adhered Flashing Products Installed BEFORE the DuPont™ Tyvek® WRB

### Key Installation Requirements for Drainable Window/Door Installation

When flashing windows or doors, the following principles must be followed:

- An integral flanged window/door is defined as a window/door unit with a nailing fin or flange that is continuous around the perimeter of the window and that is a direct extrusion of the window frame.
- Any window/door that has a nailing fin or flange that is **not continuous around the perimeter** of the window/door or the fin/flange is **not a direct extrusion of the frame** (e.g. field-applied flanges) is considered a **non-integral flanged unit**.
- When installed properly, **DuPont™ StraightFlash™**, **DuPont™ VersaFlange™**, **DuPont™ FlexWrap™**, and **DuPont™ Flashing Tape** provide nail sealability at window/door openings to help protect critical window-wall interfaces. Metal sill pan flashing may be used, but must not replace flexible sill flashing that provides nail sealability.
- Ensure that sill flashing does not slope to the interior. An exterior slope is recommended, but not required.
- Direct water onto an acceptable air and water barrier drainage plane with an unobstructed path to the exterior of the wall. Provide a drainage path for any water intrusion through the window/door attachment system that collects at the sill.
- Properly integrate flashing with acceptable **Tyvek® WRB. DuPont Self-Adhered Flashing Products** must be applied with a minimum 2" lap onto the WRB.
- When applying recommended sealant during window installation, DuPont recommends minimizing or removing excess sealant that may interfere with adhesion of **DuPont Self-Adhered Flashing Products**.
- DuPont requires that **FlexWrap™**, **FlexWrap™ EZ**, **StraightFlash™**, and **VersaFlange™** be covered within 9 months (270 days) of installation. DuPont requires that **DuPont™ Flashing Tape** be covered within 4 months (120 days) of installation.
- Properly prepare all surfaces (remove dirt, dust, or moisture, etc.) per manufacturer's recommendations.
- Barrier installations (full perimeter seal on exterior) are acceptable only in the following instances:
  - Slab on grade doors, store front windows, or other systems with built-in drainage mechanisms that have potential for exposure to standing water
  - Surface barrier wall systems with non-water sensitive framing material (i.e., CMU walls)
  - Very low wind/rain exposure regions (southwest/desert) that follow AAMA 2400 installation guideline.
- Ensure that window/door and flashing system design takes into account common factors that will impact performance, such as:
  - Climate considerations: Rainfall, Wind, Temperature (hot/cold cycles), Humidity
  - Building design: Window/Wall Design (overhangs, recessed openings, bump-outs), Wall Assembly (wood frame or masonry), Window System (wood or vinyl), New Construction or Replacement Window drainage path
  - UV exposure prior to the construction of the exterior facade
  - Compliance with fire resistance code requirements.
- Field testing the window/door and wall installation as a complete system is a recommended best practice.
- DuPont recommends DuPont Building Envelope Solutions Products be installed by a DuPont Certified Installer. Contact your local Building Envelope Specialist for more information about the DuPont Certified Installer program.

#### Sealants and Adhesives/Primers

Review the manufacturers' literature or label to confirm that the product(s) used have the chemical and adhesive properties necessary for use with **Tyvek® WRBs**, **DuPont Self-Adhered Flashing Products**, and **DuPont™ Tyvek® Fluid Applied Products**. Ensure the sealant materials meet the installation temperature requirements of the sealant manufacturer. Refer to [Chemical Compatibility of Representative Building Sealants and Adhesives/Primers](#) for more information about chemical compatibility.

## Installation Methods for DuPont Self-Adhered Flashing Products Installed BEFORE the DuPont™ Tyvek® WRB

### Integral Flanged Window

This method applies to the following products: DuPont™ Flashing Tape, DuPont™ StraightFlash™, and DuPont™ FlexWrap™

An integral flanged window is defined as a window unit with a nailing fin or flange that is continuous around the perimeter of the window and that is a direct extrusion of the window frame.

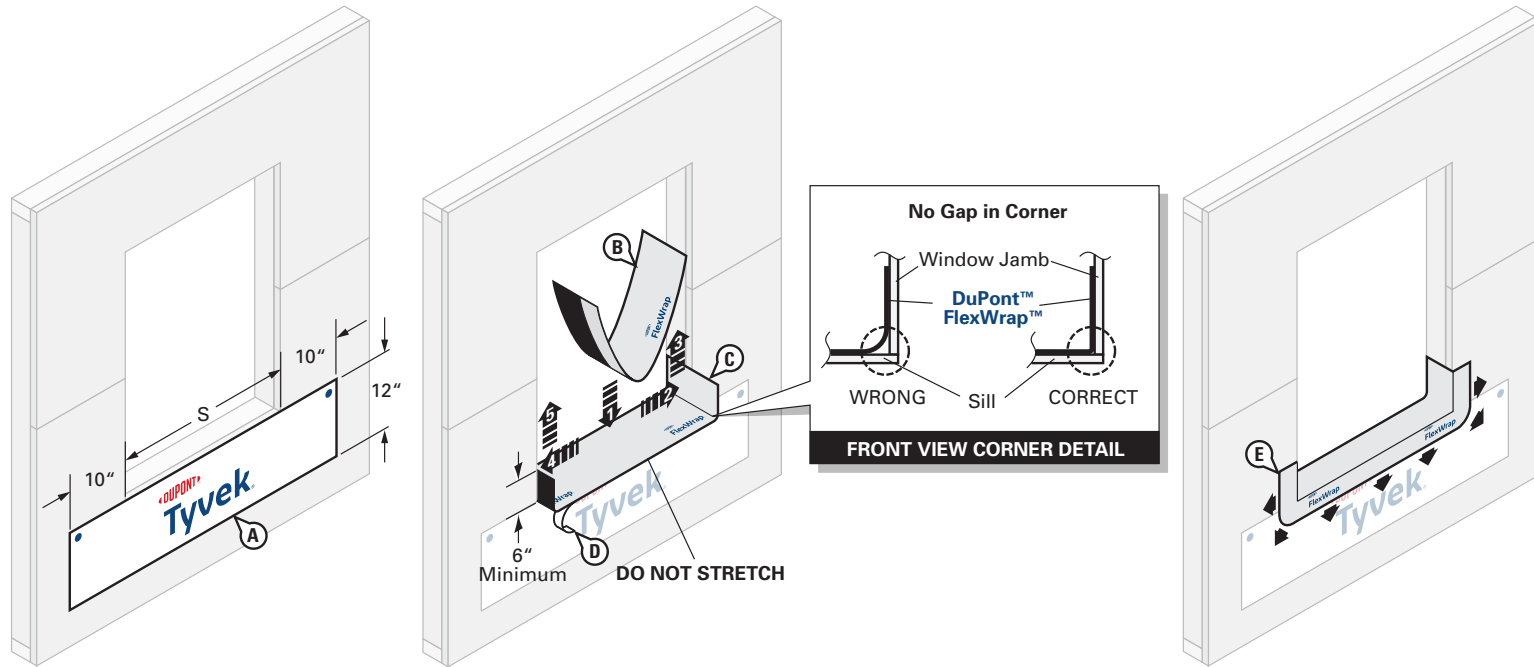

## STEP 1

### Prepare Tyvek® WRB for Apron and Sill Flashing Installation

- Cut an apron made of **Tyvek® WRB** for attachment under sill of rough opening. Apron should extend at least 10" **BEYOND** the sides of rough opening jambs (or to first stud in open stud construction) and at least 12" below sill of rough opening, or extend far enough below the sill rough opening to overlap the sill plate, base of wall flashing, or the **Tyvek® WRB** below. The top of the apron should be securely attached to the wall and the bottom of the apron should be left unsecured so it can overlap the **Tyvek® WRB** which will be installed after the window. Avoid placing **DuPont™ Tyvek® Wrap Cap Fasteners** where **DuPont Self-Adhered Flashing Products** will be installed.
- Cut **FlexWrap™** at least 12" **LONGER** than width of rough opening sill (S). Use roll widths sufficient to achieve a minimum of 1" adhesion **BEYOND** where the window frame will be located, ensuring 2"- 3" adhesion onto the face of the wall.
- Remove wide piece of release paper. Position on horizontal sill by aligning the inside edge of the narrow release paper with the face of the wall to ensure 2"- 3" of the **FlexWrap™** will be adhered to the face of the wall with a minimum of 6" up each jamb. Adhere into rough opening.
- Remove narrow release paper.
- Fan out the **FlexWrap™** at corners and adhere onto face of wall. Continue adhering onto face of wall along sill.

## Installation Methods for DuPont Self-Adhered Flashing Products Installed BEFORE the DuPont™ Tyvek® WRB Integral Flanged Window

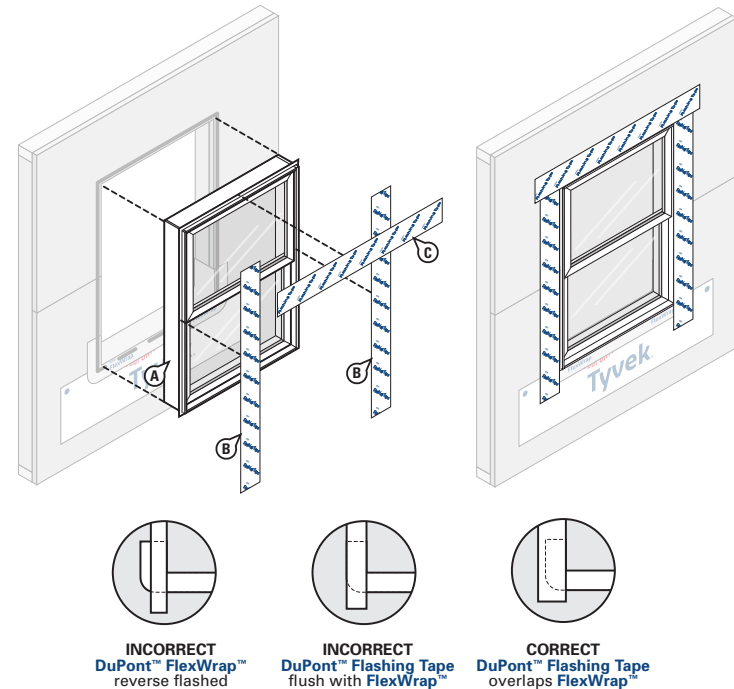
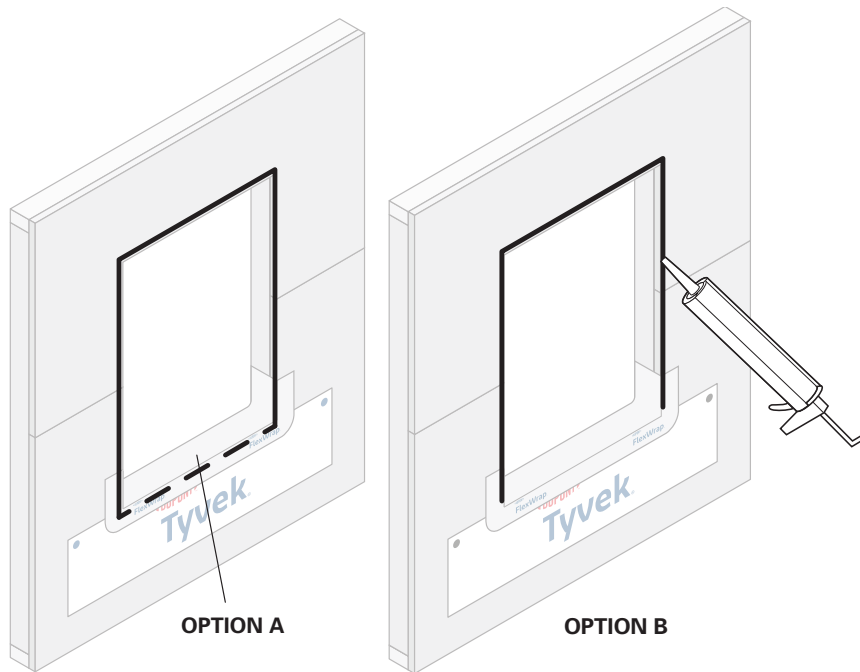

### STEP 2

**OPTION A:** Apply continuous bead of Tower® Residential Sealant, or recommended sealant, at window head and jambs to wall or back side of window mounting flange. **To allow for drainage, do not apply continuous sealant bead along sill.** Ensure a minimum 2" wide drainage gap in the sealant bead within 4" from each corner of the jamb-sill interface. Continue applying sealant along the sill with additional 2" wide (min.) drainage gaps for every 6"– 12" (on center) of sill width.

**OPTION B:** Apply continuous bead of Tower® Residential Sealant, or recommended sealant, at window head and jambs to wall or back side of window mounting flange. **To allow for drainage, do not apply sealant bead along sill.**

### STEP 3

- Install window according to manufacturer's instructions.
- Cut two pieces of **DuPont™ Flashing Tape** or **DuPont™ StraightFlash™** for jamb flashing extending 1" above window head flange and below bottom edge of sill flashing. Remove release paper and press tightly along sides of window frame. **OPTIONAL:** If installing a drip cap as part of the window installation before the **DuPont Self-Adhered Flashing Product** at the window head flange, see *Drip Cap Installation* section and refer to [Option 1](#). **NOTE:** The vertical leg of the drip cap must not be taller than the window head flange when installing drip cap according to [Option 1](#).
- Cut a piece of **DuPont™ Flashing Tape** or **StraightFlash™** for head flashing long enough to extends **BEYOND** the outer edges of jamb flashings. Remove release paper and install completely covering flange and adhering to exposed sheathing or framing members. **OPTIONAL:** If installing a drip cap as part of the window installation, but after the window head flashing, see *Drip Cap Installation* section and refer to [Option 2](#).

**NOTE:** Ensure proper shingling. **DuPont™ Flashing Tape** or **StraightFlash™** at jambs must overlap the **DuPont™ FlexWrap™** at the sill and adhere to the **Tyvek® WRB** apron below the sill.



## Installation Methods for DuPont Self-Adhered Flashing Products Installed BEFORE the DuPont™ Tyvek® WRB Integral Flanged Window

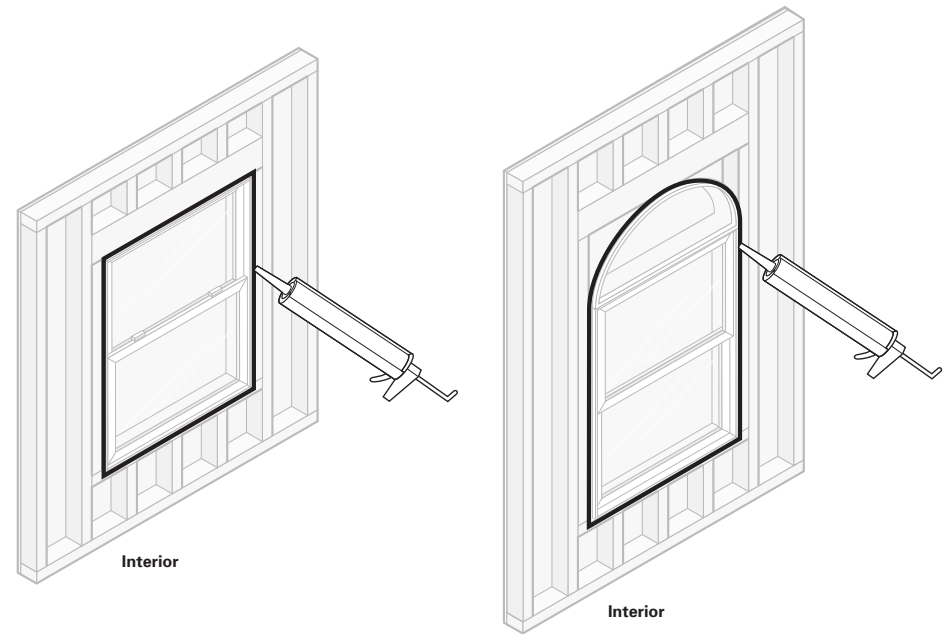
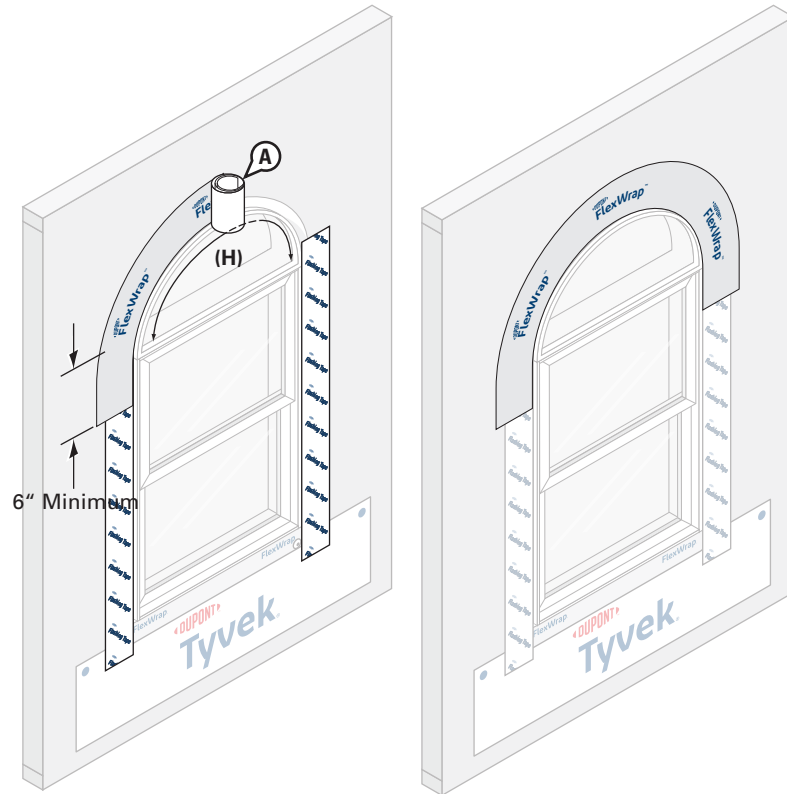

### STEP 4 – FOR ROUNDTOP WINDOWS

#### Install Head Flashing

**NOTE:** Follow rectangular window instructions (Steps 1 through 3B) for proper installation of sill and jamb flashing prior to head flashing installation.

- Cut **DuPont™ FlexWrap™** head flashing at least 12" **LONGER** than the arc length (H) of roundtop window.
- Remove both release papers and install to conform around top of window, covering entire mounting flange and adhering to exposed sheathing or framing members. Head flashing should overlap jamb flashings by at least 6".

### STEP 5

Install Tower® Residential Sealant or recommended sealant (and backer rod as necessary) around the window opening at the interior. It is also acceptable to use **Great Stuff Pro™ Window & Door Polyurethane Foam Sealant**, or recommended foam. When using Tower® Residential Sealant, tool sealant bead flat to allow the natural curing process to create a concave shape. Be sure that the sealant penetrates the grooves of the **FlexWrap™** around the sill. When using **Great Stuff Pro™ Window & Door Polyurethane Foam Sealant** in perimeter openings less than 1/2", apply using the plastic extension tip for the **Great Stuff Pro™ Dispensing Gun** during installation.

## Installation Methods for DuPont Self-Adhered Flashing Products Installed BEFORE the DuPont™ Tyvek® WRB Integral Flanged Window

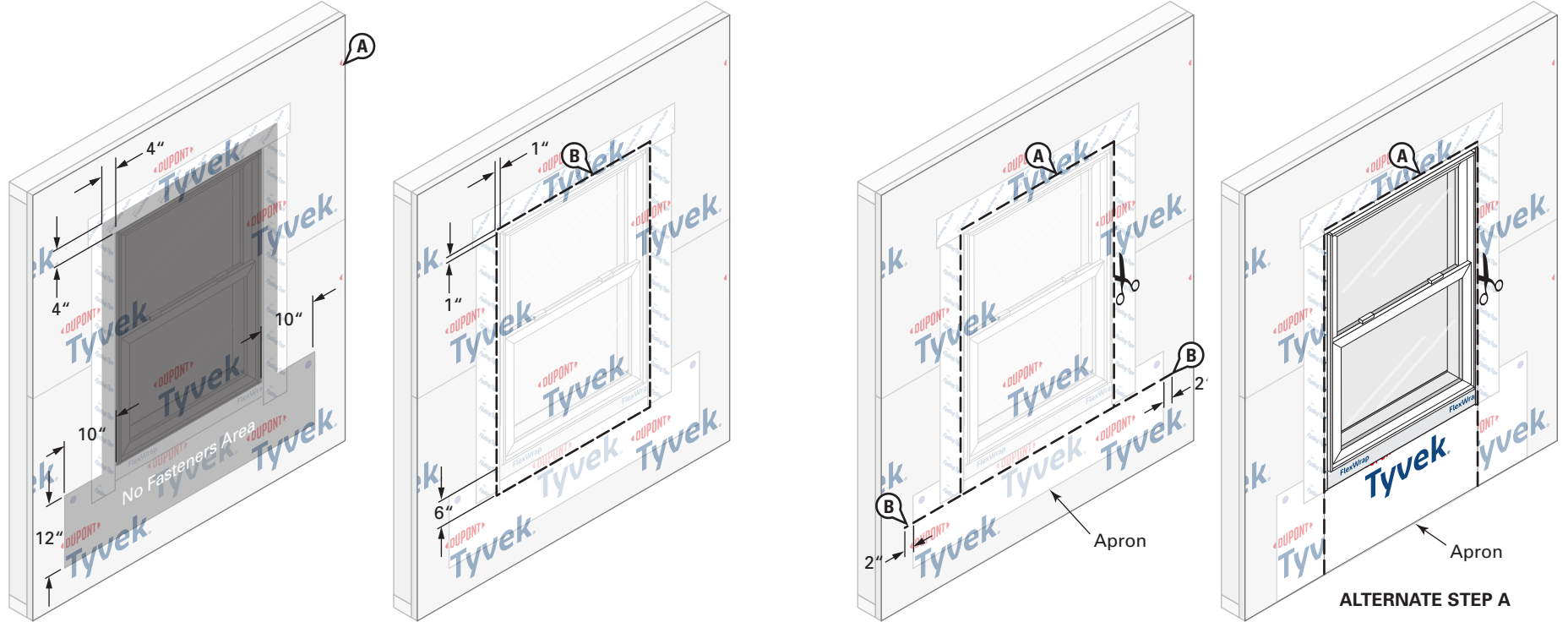

### STEP 6

- A. Install the **Tyvek® WRB** as shown in the [DuPont™ Tyvek® WRB Installation Instructions](#) section of this document. Do not install fasteners within 4" of the window frame at jambs and head and within 12" of the window frame at sill or location of apron.
- B. Mark a perimeter on the **Tyvek® WRB** around the rough opening a minimum of 1" from the jambs and head of the window frame, and 6" below the sill of the window frame.

### STEP 7

- A. Cut the **Tyvek® WRB** along perimeter marking to expose window. Do not cut through the **DuPont Self-Adhered Flashing Products** or **Tyvek® WRB** apron underneath.

**ALTERNATE STEP A:** If apron extends far enough below the sill rough opening to overlap the sill plate, base of wall flashing, or the **Tyvek® WRB** below, the **Tyvek® WRB** can be cut along jambs and head only to overlap apron.

- B. Create horizontal slits in the **Tyvek® WRB** at each lower corner of the perimeter cut that extend 1"– 2" **BEYOND** the **Tyvek® WRB** apron.

## Installation Methods for DuPont Self-Adhered Flashing Products Installed BEFORE the DuPont™ Tyvek® WRB Integral Flanged Window

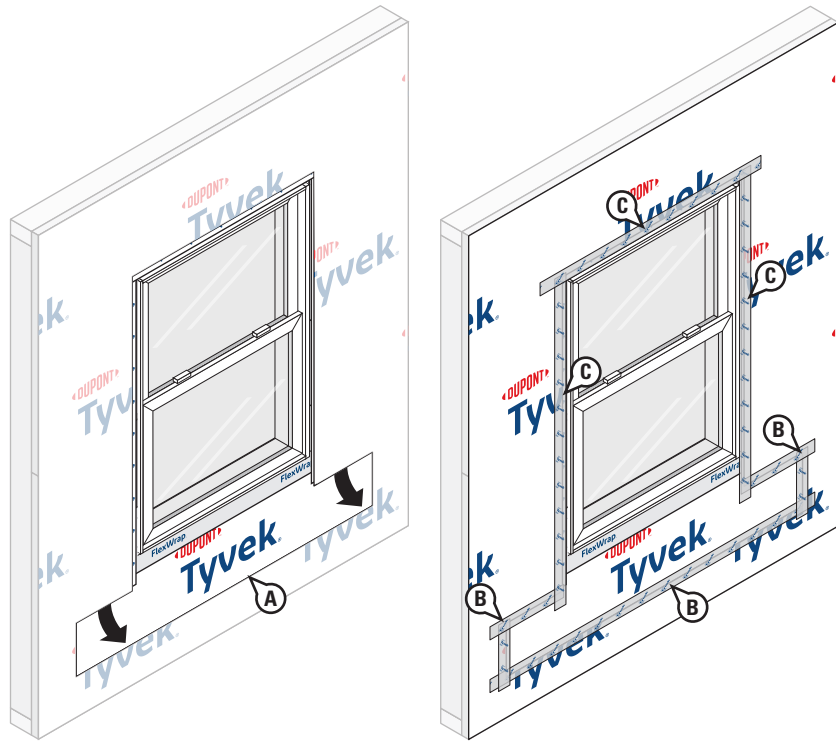

### STEP 8

#### Final Step

- A. Bring the bottom portion of the **Tyvek® WRB** apron through the sill perimeter cut and horizontal slits so it laps over the top layer of **Tyvek® WRB**.
- B. Working from bottom to top, install **DuPont™ Tyvek® Tape** to secure horizontal and vertical seams of the **Tyvek® WRB** apron.
- C. Install **Tyvek® Tape** along jambs and head to seal **Tyvek® WRB** around window. For a more robust termination, **DuPont™ Flashing Tape** or **DuPont™ StraightFlash™** can be used.

## Installation Methods for DuPont Self-Adhered Flashing Products Installed BEFORE the DuPont™ Tyvek® WRB Integral Flanged Adjacent Rectangular Windows (with Less Than 6" of Sheathing/Framing Between Windows)

### Option 1 – When Using DuPont™ Tyvek® WRB at Sheathing/Framing Separating Adjacent Windows

This method applies to the following products: DuPont™ Flashing Tape, DuPont™ StraightFlash™, and DuPont™ FlexWrap™

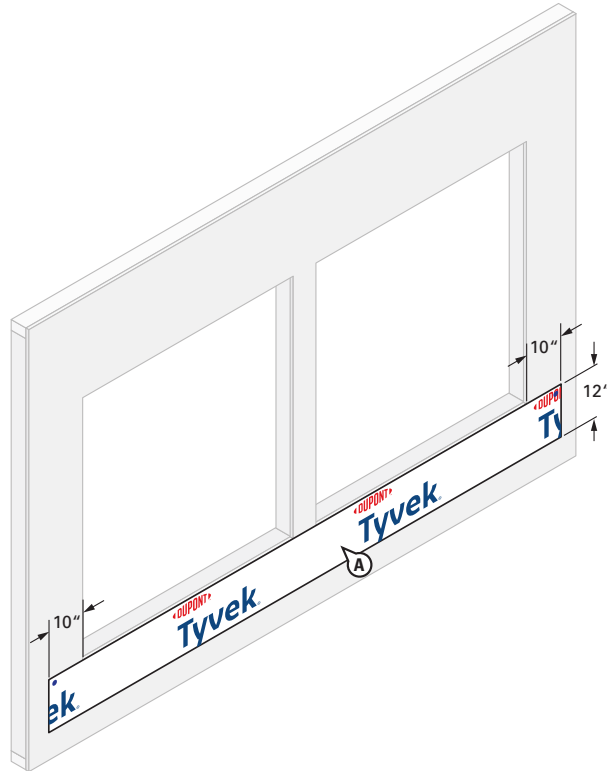

## STEP 1

### Prepare Tyvek® WRB Apron

- A. Cut a single apron made of **Tyvek® WRB** for attachment under both sills of rough opening. Apron should extend at least 10" **BEYOND** the left and right sides of each rough opening jamb (or to first stud in open stud construction) and at least 12" below sill of rough opening, or extend far enough below the sill rough opening to overlap the sill plate, base of wall flashing, or the **Tyvek® WRB** below.

The top of the apron should be securely attached to the wall and the bottom of the apron should be left unsecured so it can overlap the **Tyvek® WRB** which will be installed after the windows. Avoid placing **DuPont™ Tyvek® Wrap Cap Fasteners** where **DuPont Self-Adhered Flashing Products** will be installed.



## Installation Methods for DuPont Self-Adhered Flashing Products Installed BEFORE the DuPont™ Tyvek® WRB Integral Flanged Adjacent Rectangular Windows (with Less Than 6" of Sheathing/Framing Between Windows)

### Option 1 – When Using DuPont™ Tyvek® WRB at Sheathing/Framing Separating Adjacent Windows

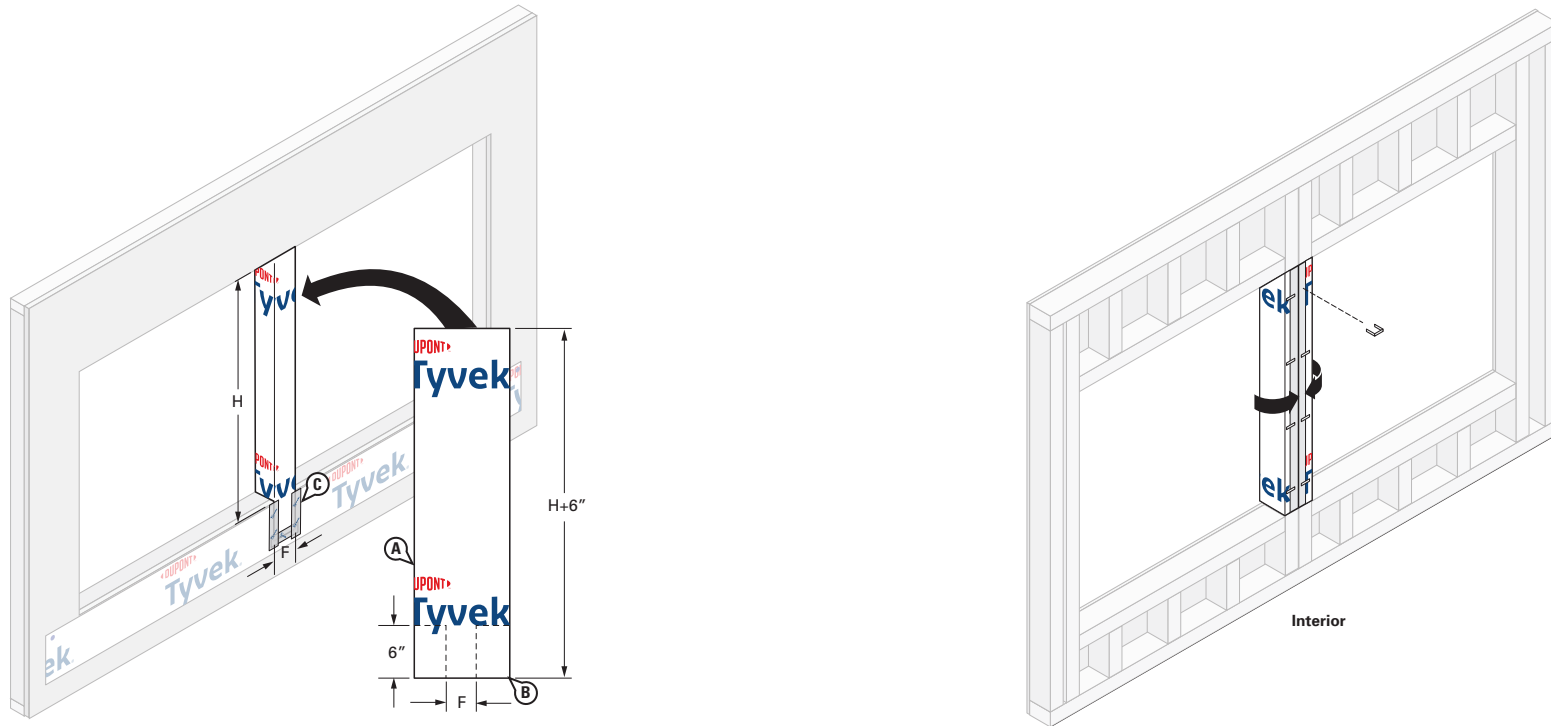

## STEP 2

### Preparation of Framing/Sheathing Separating Adjacent Windows Using Tyvek® WRB.

- Cut a piece of **Tyvek® WRB** wide enough to cover the framing/sheathing between windows when wrapped into the window rough openings and 6" longer than the height (H) of the rough opening.
- Cut corners to create side flaps that will fold into adjacent window rough openings with 6" of the **Tyvek® WRB** piece extending below the rough openings.
- Install **Tyvek® WRB** piece onto the framing/sheathing between windows. Do not install fasteners within 6" of the rough openings. **DuPont™ Tyvek® Tape** may be used if necessary to hold **Tyvek® WRB** piece in place. Seal vertical seams below window with Tyvek® Tape.
- Fold the two side flaps into rough opening, and secure. Cut off excess flaps if necessary.

## Installation Methods for DuPont Self-Adhered Flashing Products Installed **BEFORE** the DuPont™ Tyvek® WRB Integral Flanged Adjacent Rectangular Windows (with Less Than 6" of Sheathing/Framing Between Windows)

### Option 1 – When Using DuPont™ Tyvek® WRB at Sheathing/Framing Separating Adjacent Windows

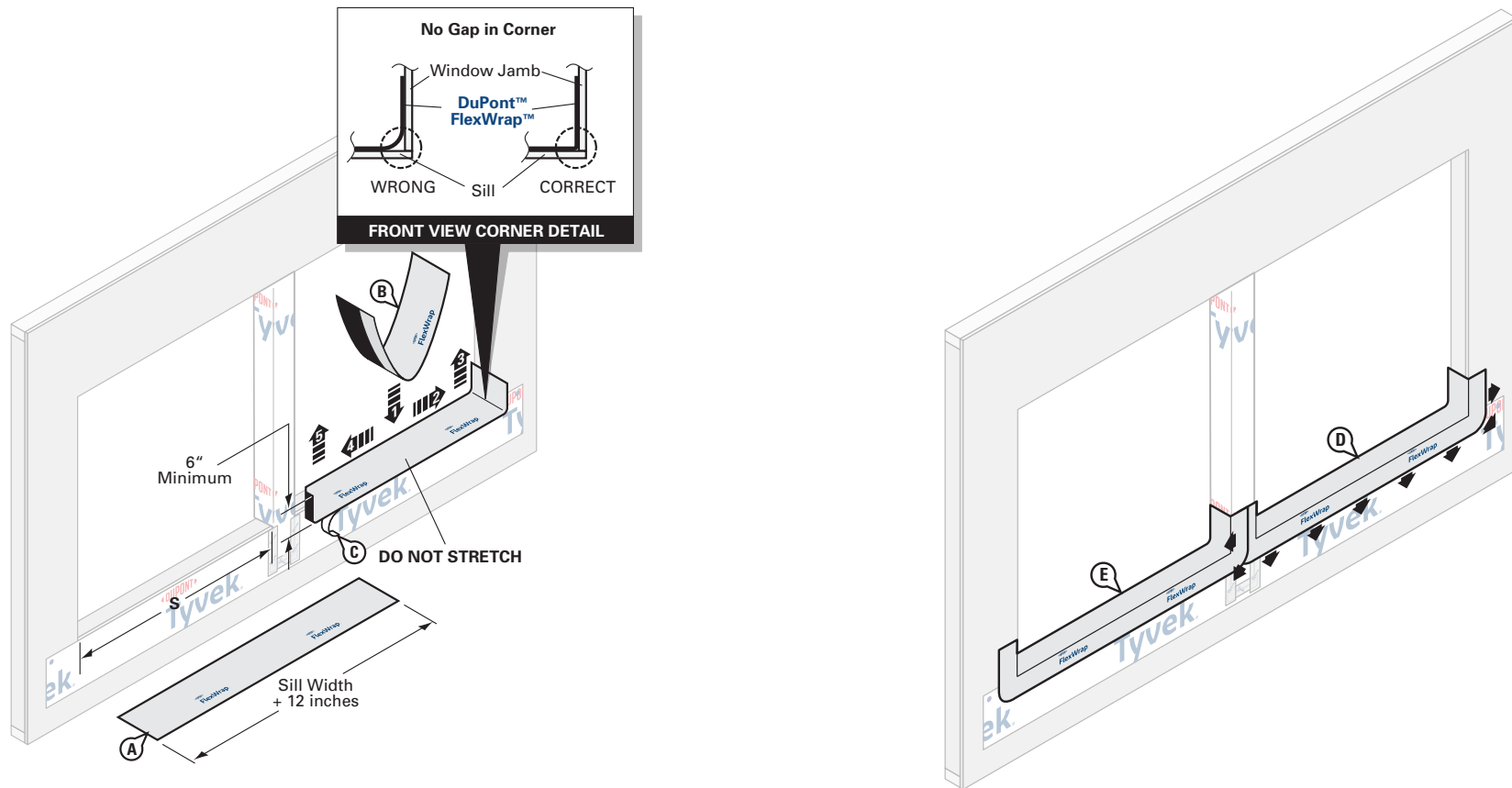

### STEP 3

- A. Cut 2 pieces of **DuPont™ FlexWrap™** at least 12" **LONGER** than width of rough opening sill (S). Use roll widths sufficient to achieve a minimum of 1" adhesion **BEYOND** where the window frame will be located, ensuring 2"– 3" adhesion onto the face of the wall.
- B. Remove wide piece of release paper from the first piece of **FlexWrap™**. Position on horizontal sill by aligning the inside edge of the narrow release paper with the face of the wall to ensure 2"– 3" of the **FlexWrap™** will be adhered to the face of the wall with a minimum of 6" up each jamb. Adhere into rough opening.
- C. Remove narrow release paper from the **FlexWrap™**.
- D. Fan out the **FlexWrap™** at bottom corners onto face of wall and framing/ sheathing between windows.
- E. Repeat Steps B-D for second window. **NOTE:** The **FlexWrap™** installed in the second window may overlap the **FlexWrap™** installed in the first window at the vertical exposed sheathing/framing separating the windows.

## Installation Methods for DuPont Self-Adhered Flashing Products Installed BEFORE the DuPont™ Tyvek® WRB Integral Flanged Adjacent Rectangular Windows (with Less Than 6" of Sheathing/Framing Between Windows)

### Option 1 – When Using DuPont™ Tyvek® WRB at Sheathing/Framing Separating Adjacent Windows

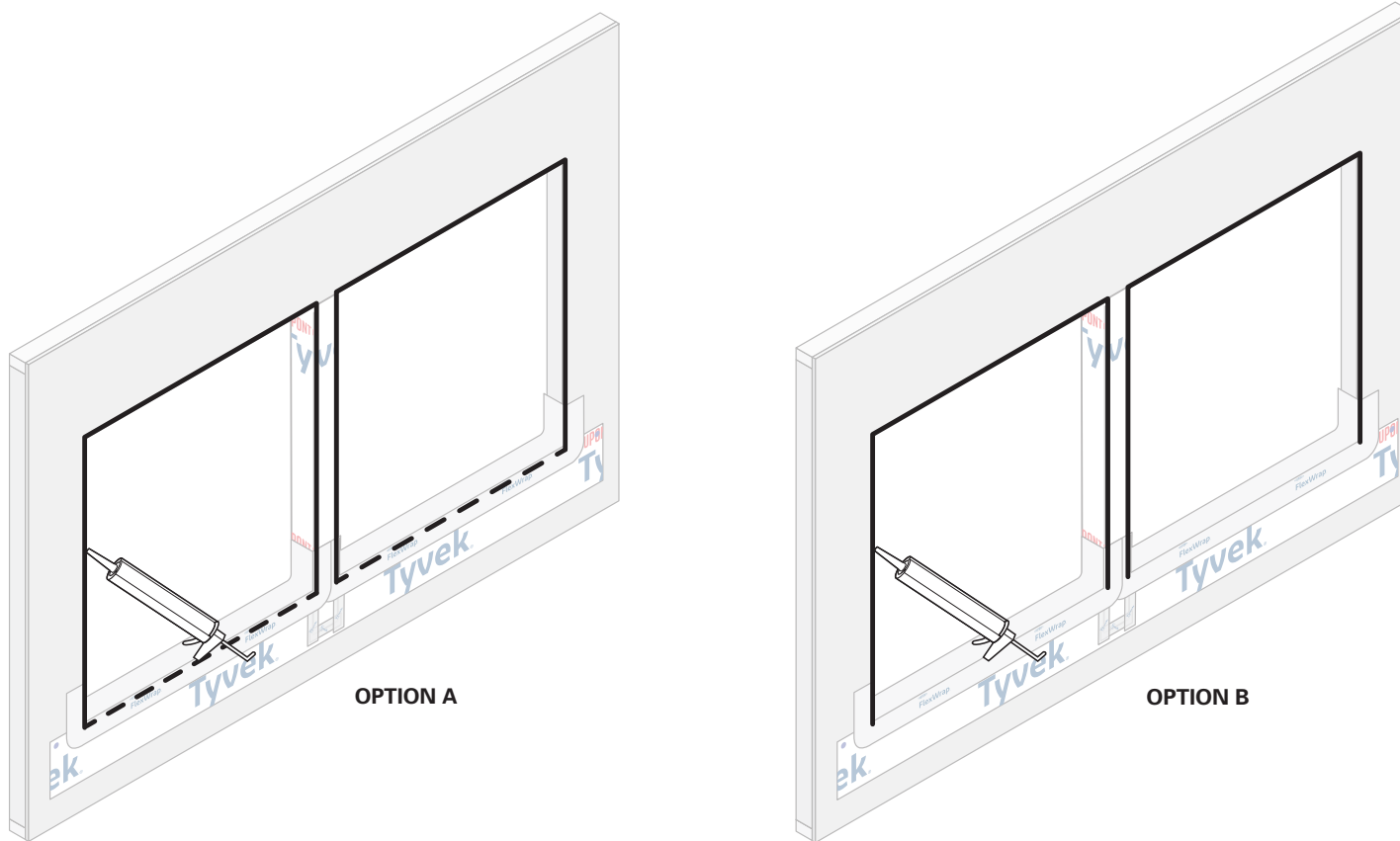

#### STEP 4

**OPTION A:** Apply continuous bead of Tower® Residential Sealant, or recommended sealant, at window head and jambs to wall or back side of window mounting flange. **To allow for drainage, do not apply continuous sealant bead along sill.** Ensure a minimum 2" wide drainage gap in the sealant bead within 4" from **each corner** of the jamb-sill interface. Continue applying sealant along the sill with additional 2" wide (min.) drainage gaps for every 6"–12" (on center) of sill width.

**OPTION B:** Apply continuous bead of Tower® Residential Sealant, or recommended sealant, at window head and jambs to wall or back side of window mounting flange. **To allow for drainage, do not apply sealant bead along sill.**

## Installation Methods for DuPont Self-Adhered Flashing Products Installed BEFORE the DuPont™ Tyvek® WRB Integral Flanged Adjacent Rectangular Windows (with Less Than 6" of Sheathing/Framing Between Windows)

### Option 1 – When Using DuPont™ Tyvek® WRB at Sheathing/Framing Separating Adjacent Windows

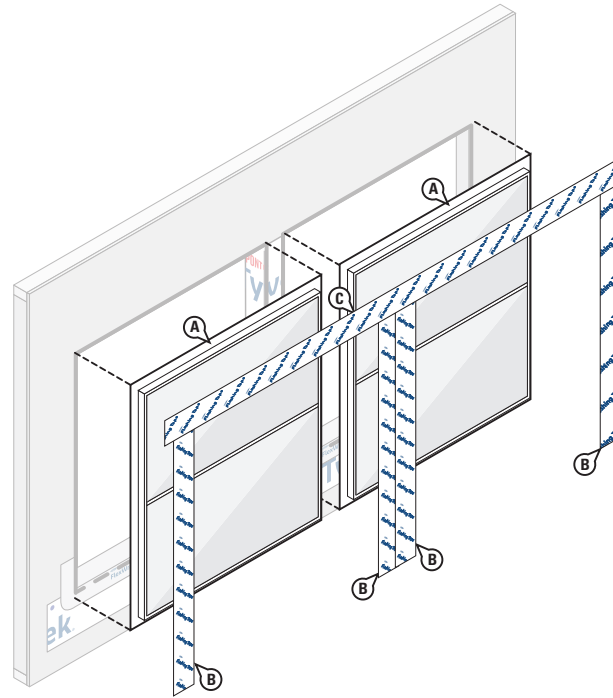

### STEP 5

A. Install windows according to manufacturer's instructions.

B. Cut four pieces of **DuPont™ Flashing Tape** or **DuPont™ StraightFlash™** for jamb flashing extending 1" above window head flanges and below bottom edge of sill flashing. Remove release paper and press tightly along sides of window frame.

**NOTE:** The **DuPont™ Flashing Tape** or **StraightFlash™** for the inside jamb flashing of one window may overlap the **DuPont™ Flashing Tape** or **StraightFlash™** on the inside jamb of the other window.

**NOTE:** If the inside jamb flanges of the two windows are sufficiently close, it is acceptable to use a single piece of **DuPont™ Flashing Tape** or **StraightFlash™** to cover both inside jamb flanges. Select roll width wide enough to fully cover both jamb flanges.

**OPTIONAL:** If installing a drip cap as part of the window installation before the **DuPont Self-Adhered Flashing** membrane at the window head flange, see *Drip Cap Installation* section and refer to [Option 1](#). The vertical leg of the drip cap must not be taller than the window head flange when installing drip cap according to [Option 1](#).

C. Cut a piece of **DuPont™ Flashing Tape** or **StraightFlash™** for head flashing long enough to extend **BEYOND** the edges of flashing at outer jambs. Remove release paper and adhere to head flanges, extending onto sheathing. The **DuPont Self-Adhered Flashing** membrane over the window must extend **BEYOND** the top edge of the **DuPont Self-Adhered Flashing** membrane previously installed between windows.

**NOTE:** Ensure proper shingling. **DuPont™ Flashing Tape** or **StraightFlash™** at jambs must overlap the **DuPont™ FlexWrap™** at the sill and adhere to the **Tyvek® WRB** apron below the sill.

**OPTIONAL:** If installing a drip cap as part of the window installation, but after the window head flashing, see *Drip Cap Installation* section and refer to [Option 2](#).



## Installation Methods for DuPont Self-Adhered Flashing Products Installed BEFORE the DuPont™ Tyvek® WRB Integral Flanged Adjacent Rectangular Windows (with Less Than 6" of Sheathing/Framing Between Windows)

### Option 1 – When Using DuPont™ Tyvek® WRB at Sheathing/Framing Separating Adjacent Windows

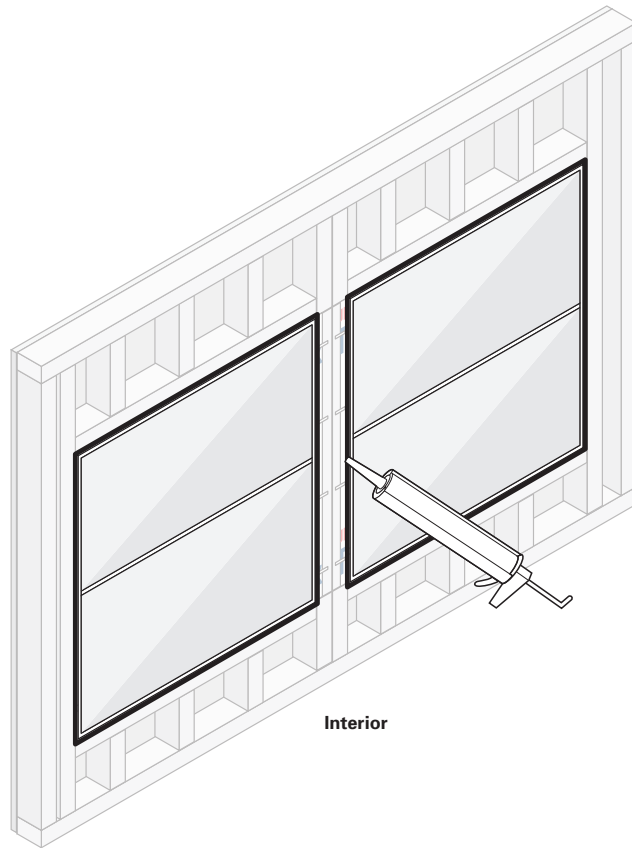

#### STEP 6

Install Tower® Residential Sealant or recommended sealant (and backer rod as necessary) around the window opening at the interior. It is also acceptable to use **Great Stuff Pro™ Window & Door Polyurethane Foam Sealant**, or recommended foam. When using Tower® Residential Sealant, tool sealant bead flat to allow the natural curing process to create a concave shape. Be sure that the sealant penetrates the grooves of the **DuPont™ FlexWrap™** around the sill. When using **Great Stuff Pro™ Window & Door Polyurethane Foam Sealant** in perimeter openings less than 1/2", apply using the plastic extension tip for the **Great Stuff Pro™ Dispensing Gun** during installation.

## Installation Methods for DuPont Self-Adhered Flashing Products Installed BEFORE the DuPont™ Tyvek® WRB Integral Flanged Adjacent Rectangular Windows (with Less Than 6" of Sheathing/Framing Between Windows)

### Option 1 – When Using DuPont™ Tyvek® WRB at Sheathing/Framing Separating Adjacent Windows

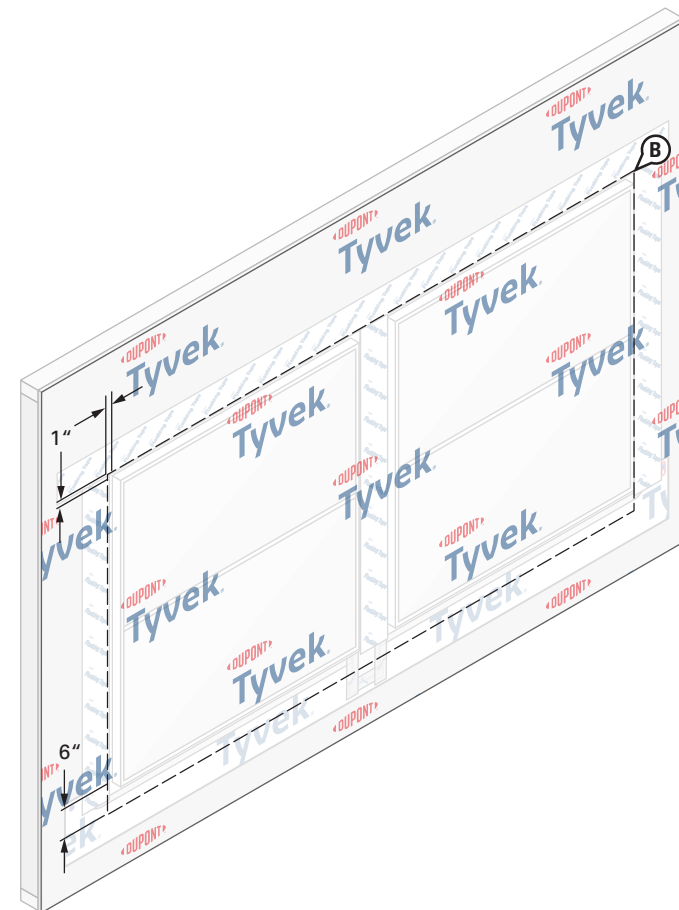
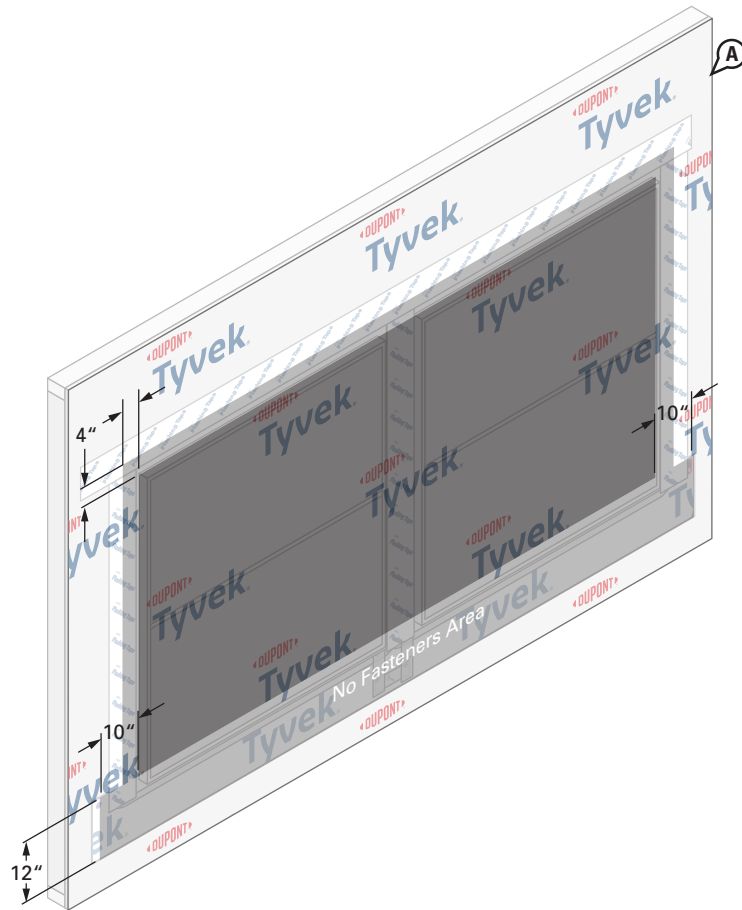

## STEP 7

A. Install the **Tyvek® WRB** as shown in the [DuPont™ Tyvek® WRB Installation Instructions](#) section of this document. Do not install fasteners within 4" of the window frames at outside jamb and heads and within 12" of the window frames at sills or location of apron.

B. Mark a perimeter on the **Tyvek® WRB** around the rough openings a minimum of 1" from the outside jamb and heads of the window frames, and 6" below the sill of the window frames.

## Installation Methods for DuPont Self-Adhered Flashing Products Installed BEFORE the DuPont™ Tyvek® WRB Integral Flanged Adjacent Rectangular Windows (with Less Than 6" of Sheathing/Framing Between Windows)

### Option 1 – When Using DuPont™ Tyvek® WRB at Sheathing/Framing Separating Adjacent Windows

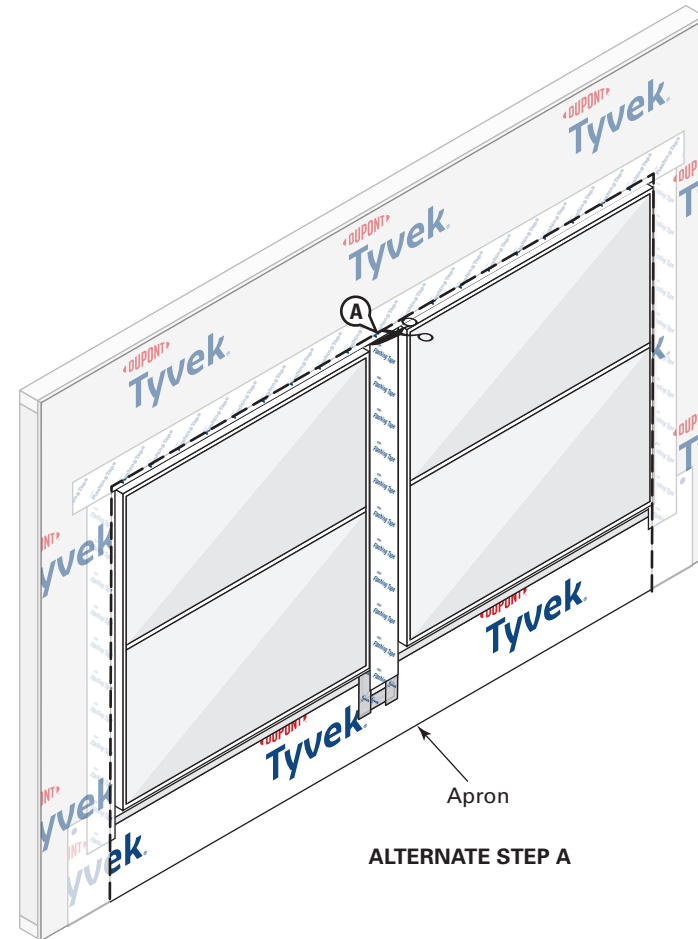
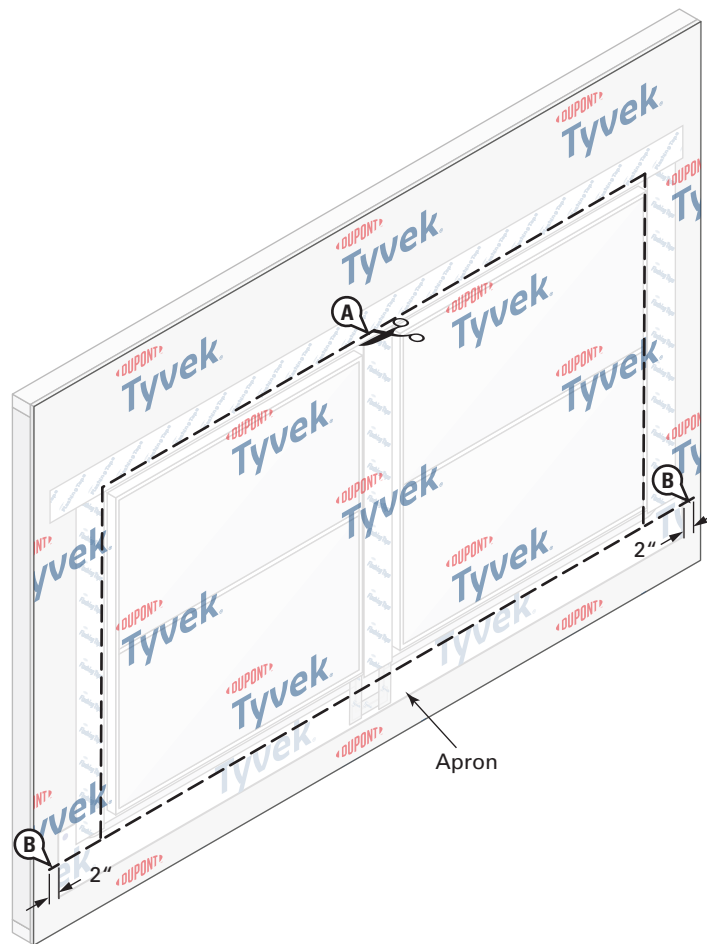

### STEP 8

- Cut the **Tyvek® WRB** along perimeter marking to expose windows. Do not cut through the **DuPont Self-Adhered Flashing Products** or **Tyvek® WRB** apron underneath.
- Create horizontal slits in the **Tyvek® WRB** at each lower corner of the perimeter cut that extend 1"- 2" **BEYOND** the **Tyvek® WRB** apron.

**ALTERNATE STEP A:** If apron extends far enough below the sill rough openings to overlap the sill plate, base of wall flashing, or the **Tyvek® WRB** below, the **Tyvek® WRB** can be cut along jambs and head only to overlap apron.

## Installation Methods for DuPont Self-Adhered Flashing Products Installed BEFORE the DuPont™ Tyvek® WRB Integral Flanged Adjacent Rectangular Windows (with Less Than 6" of Sheathing/Framing Between Windows)

### Option 1 – When Using DuPont™ Tyvek® WRB at Sheathing/Framing Separating Adjacent Windows

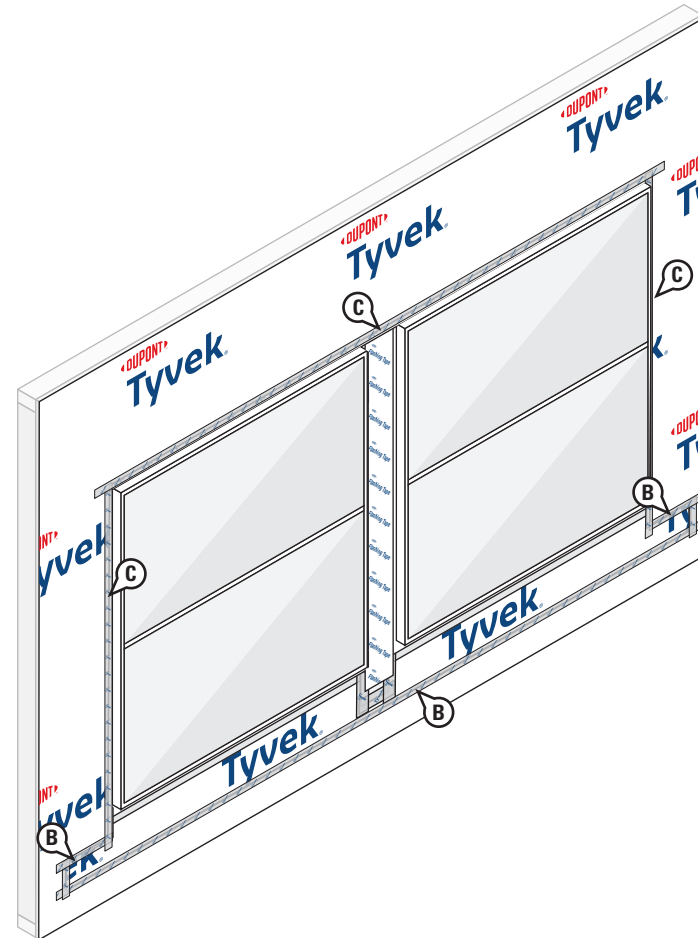
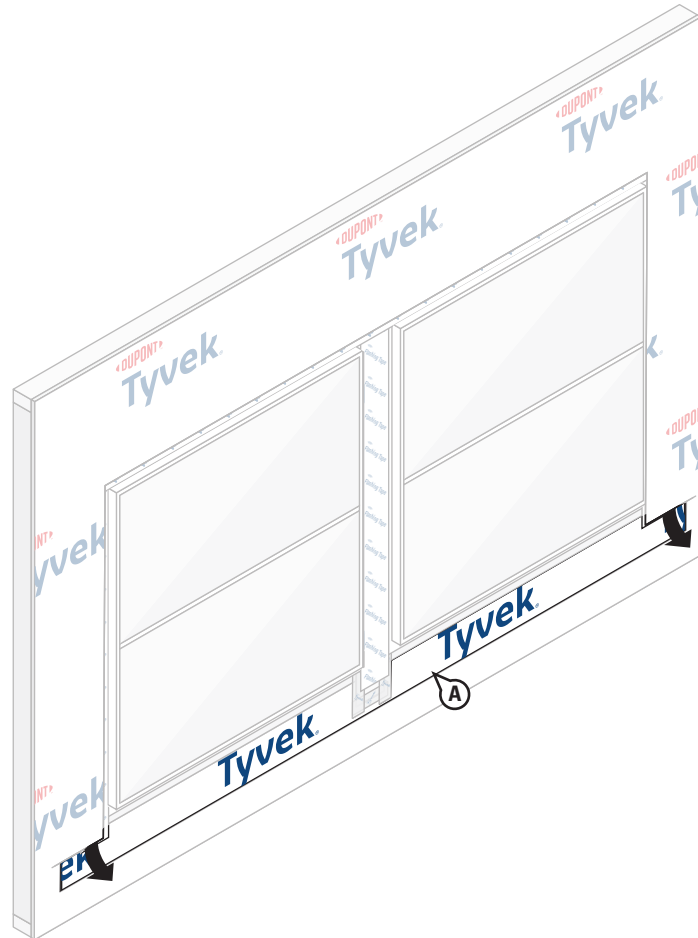

## STEP 9

### Final Step

- Bring the bottom portion of the **Tyvek® WRB** apron through the sill perimeter cut and horizontal slits so it laps over the top layer of **Tyvek® WRB**.
- Working from bottom to top, install **DuPont™ Tyvek® Tape** to secure horizontal and vertical seams of the **Tyvek® WRB** apron.
- Install **Tyvek® Tape** along jambs and head to seal **Tyvek® WRB** around windows. For a more robust termination, **DuPont™ Flashing Tape** or **DuPont™ StraightFlash™** can be used.

**OPTIONAL:** If installing a drip cap **AFTER** the **Tyvek® WRB** is installed and sealed around perimeter of windows, see *Drip Cap Installation* section and refer to [Option 3](#).



## Installation Methods for DuPont Self-Adhered Flashing Products Installed **BEFORE** the DuPont™ Tyvek® WRB Integral Flanged Adjacent Rectangular Windows (with Less Than 6" of Sheathing/Framing Between Windows)

Option 2 – When Using DuPont Self-Adhered Flashing Product at Sheathing/Framing Separating Adjacent Windows

This method applies to the following products: DuPont™ Flashing Tape, DuPont™ StraightFlash™, and DuPont™ FlexWrap™

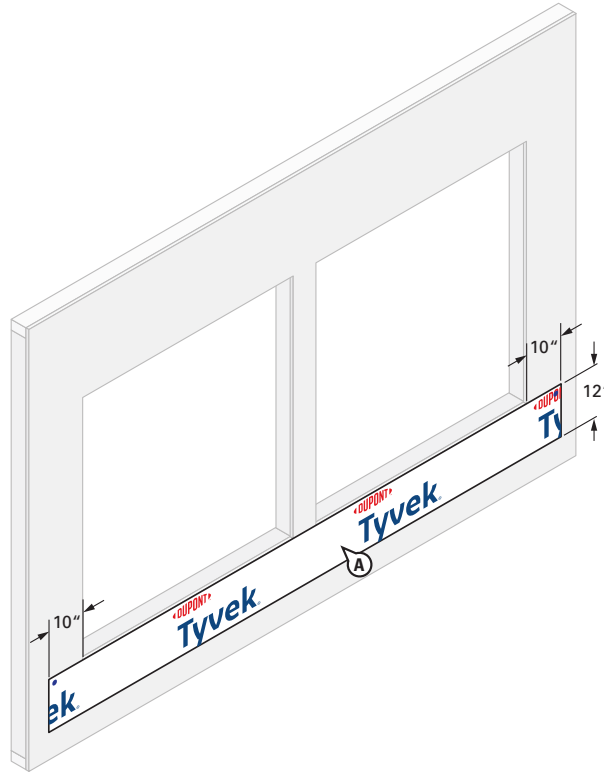

### STEP 1

#### Prepare Tyvek® WRB Apron

- A. Cut a single apron made of Tyvek® WRB for attachment under both sills of rough opening. Apron should extend at least 10" **BEYOND** the left and right sides of each rough opening jamb (or to first stud in open stud construction) and at least 12" below sill of rough opening, or extend far enough below the sill rough opening to overlap the sill plate, base of wall flashing, or the Tyvek® WRB below.

The top of the apron should be securely attached to the wall and the bottom of the apron should be left unsecured so it can overlap the Tyvek® WRB which will be installed after the windows. Avoid placing DuPont™ Tyvek® Wrap Cap Fasteners where DuPont Self-Adhered Flashing Products will be installed.

## Installation Methods for DuPont Self-Adhered Flashing Products Installed BEFORE the DuPont™ Tyvek® WRB Integral Flanged Adjacent Rectangular Windows (with Less Than 6" of Sheathing/Framing Between Windows)

### Option 2 – When Using DuPont Self-Adhered Flashing Product at Sheathing/Framing Separating Adjacent Windows

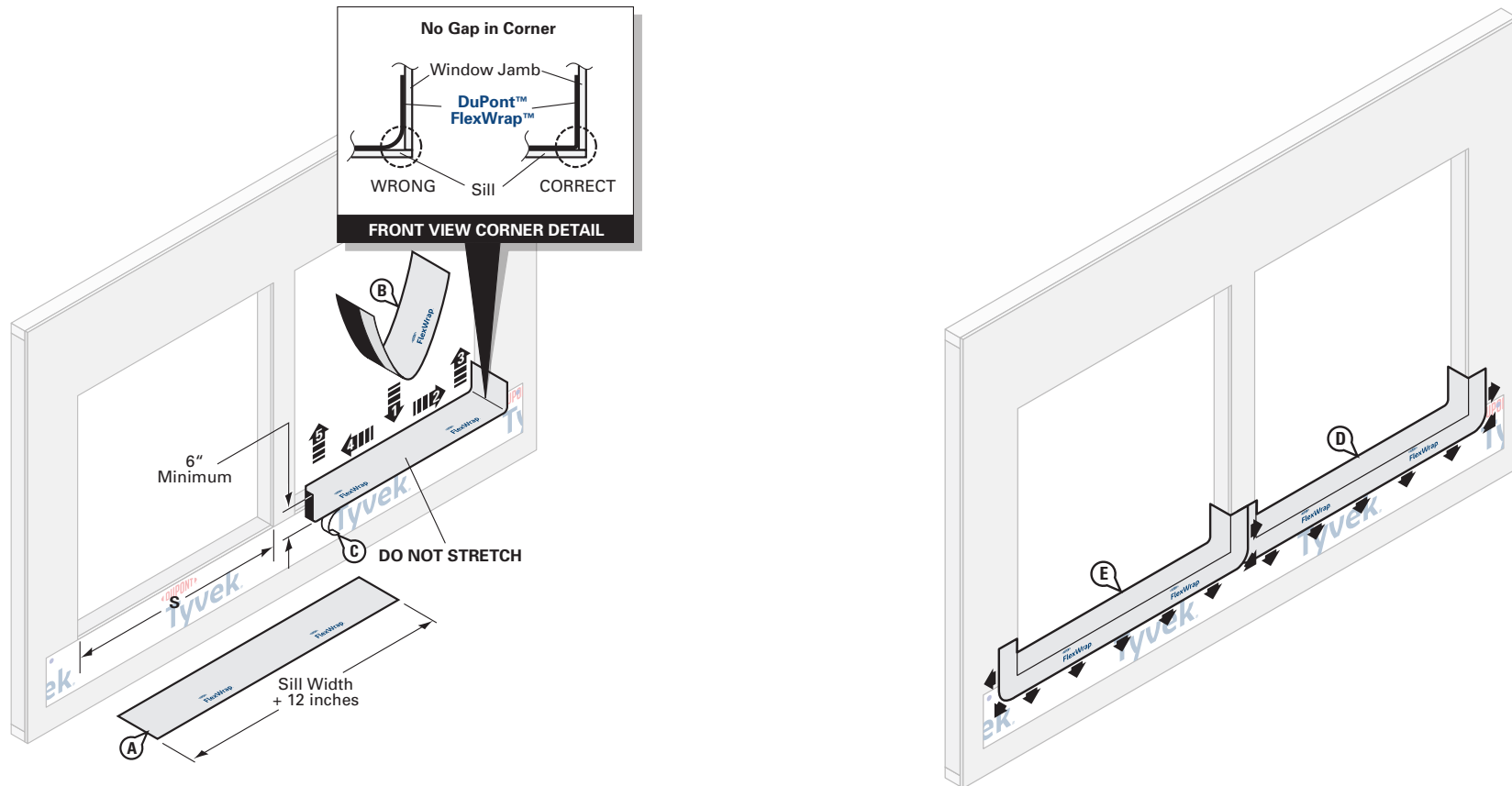

## STEP 2

- Cut 2 pieces of **DuPont™ FlexWrap™** at least 12" **LONGER** than width of rough opening sill (S). Use roll widths sufficient to achieve a minimum of 1" adhesion **BEYOND** where the window frame will be located, ensuring 2"– 3" adhesion onto the face of the wall.
- Remove wide piece of release paper from the first piece of **FlexWrap™**. Position on horizontal sill by aligning the inside edge of the narrow release paper with the face of the wall to ensure 2"– 3" of the **FlexWrap™** will be adhered to the face of the wall with a minimum of 6" up each jamb. Adhere into rough opening.
- Remove narrow release paper from the **FlexWrap™**.
- Fan out the **FlexWrap™** at bottom corners onto face of wall and framing/sheathing between windows.
- Repeat Steps B-D for second window. **NOTE:** The **FlexWrap™** installed in the second window may overlap the **FlexWrap™** installed in the first window at the vertical exposed sheathing/framing separating the windows.

## Installation Methods for DuPont Self-Adhered Flashing Products Installed **BEFORE** the DuPont™ Tyvek® WRB Integral Flanged Adjacent Rectangular Windows (with Less Than 6" of Sheathing/Framing Between Windows)

### Option 2 – When Using DuPont Self-Adhered Flashing Product at Sheathing/Framing Separating Adjacent Windows

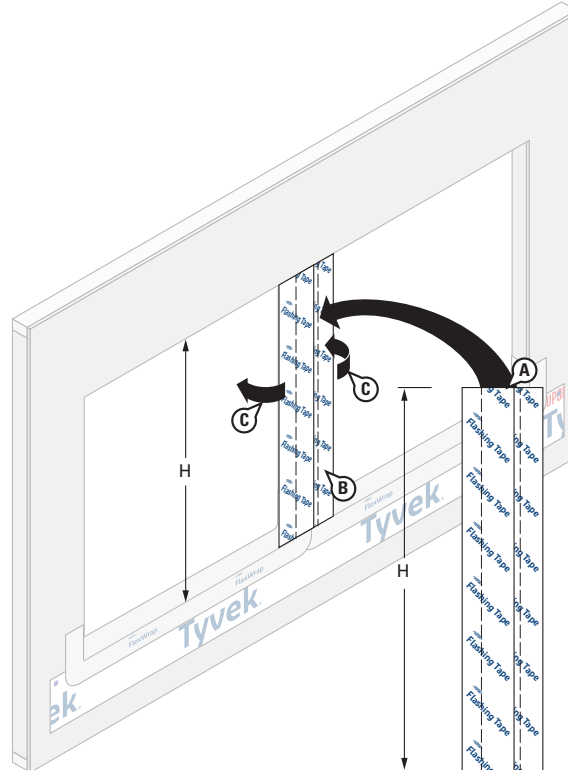

### STEP 3

- Cut a piece of 9" wide **DuPont™ Flashing Tape** or **DuPont™ StraightFlash™** the height (H) of the rough opening.
- NOTE:** For adjacent windows separated by a wider shared sheathing/framing, two overlapping pieces of **DuPont™ Flashing Tape** or **StraightFlash™** may be required. When the flashing is folded into the opening per Step C. It should extend minimum 1" **BEYOND** where the window frame will be located.
- Remove release paper and center the **DuPont™ Flashing Tape** or **StraightFlash™** onto the face of the vertical exposed framing/sheathing with the bottom edge aligned with the sill rough opening. Adhere the exposed butyl onto the face of the vertical exposed framing sheathing.
- Fold the resulting **DuPont™ Flashing Tape** or **StraightFlash™** flaps into the rough opening and adhere.

## Installation Methods for DuPont Self-Adhered Flashing Products Installed BEFORE the DuPont™ Tyvek® WRB Integral Flanged Adjacent Rectangular Windows (with Less Than 6" of Sheathing/Framing Between Windows)

### Option 2 – When Using DuPont Self-Adhered Flashing Product at Sheathing/Framing Separating Adjacent Windows

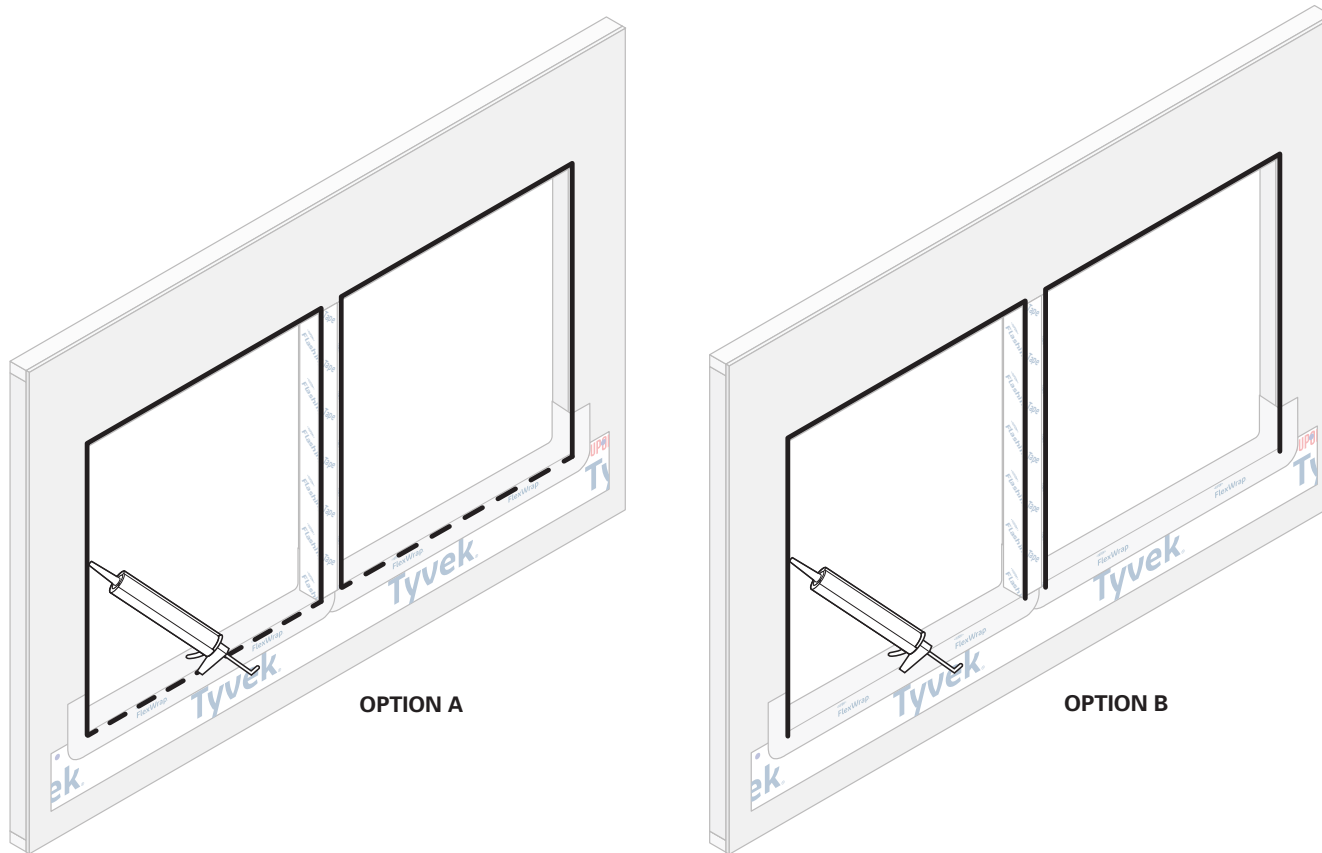

#### STEP 4

**OPTION A:** Apply continuous bead of Tower® Residential Sealant, or recommended sealant, at window head and jambs to wall or back side of window mounting flange. **To allow for drainage, do not apply continuous sealant bead along sill.** Ensure a minimum 2" wide drainage gap in the sealant bead within 4" from **each corner** of the jamb-sill interface. Continue applying sealant along the sill with additional 2" wide (min.) drainage gaps for every 6"– 12" (on center) of sill width.

**OPTION B:** Apply continuous bead of Tower® Residential Sealant, or recommended sealant, at window head and jambs to wall or back side of window mounting flange. **To allow for drainage, do not apply sealant bead along sill.**



## Installation Methods for DuPont Self-Adhered Flashing Products Installed BEFORE the DuPont™ Tyvek® WRB Integral Flanged Adjacent Rectangular Windows (with Less Than 6" of Sheathing/Framing Between Windows)

### Option 2 – When Using DuPont Self-Adhered Flashing Product at Sheathing/Framing Separating Adjacent Windows

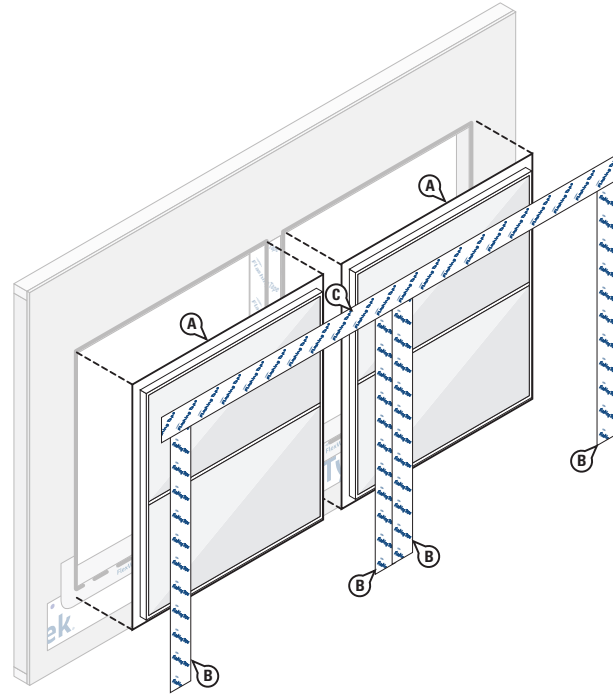

#### STEP 5

A. Install windows according to manufacturer's instructions.

B. Cut four pieces of **DuPont™ Flashing Tape** or **DuPont™ StraightFlash™** for jamb flashing extending 1" above window head flanges and below bottom edge of sill flashing. Remove release paper and press tightly along sides of window frame.

**NOTE:** The **DuPont™ Flashing Tape** or **StraightFlash™** for the inside jamb flashing of one window may overlap the **DuPont™ Flashing Tape** or **StraightFlash™** on the inside jamb of the other window.

**NOTE:** If the inside jamb flanges of the two windows are sufficiently close, it is acceptable to use a single piece of **DuPont™ Flashing Tape** or **StraightFlash™** to cover both inside jamb flanges. Select roll width wide enough to fully cover both jamb flanges.

**OPTIONAL:** If installing a drip cap as part of the window installation before the **DuPont Self-Adhered Flashing** membrane at the window head flange, see *Drip Cap Installation* section and refer to [Option 1](#). The vertical leg of the drip cap must not be taller than the window head flange when installing drip cap according to [Option 1](#).

C. Cut a piece of **DuPont™ Flashing Tape** or **StraightFlash™** for head flashing long enough to extend **BEYOND** the edges of flashing at outer jamba. Remove release paper and adhere to head flanges, extending onto sheathing. The **DuPont Self-Adhered Flashing** membrane over the window must extend **BEYOND** the top edge of the **DuPont Self-Adhered Flashing** membrane previously installed between windows.

**NOTE:** Ensure proper shingling. **DuPont™ Flashing Tape** or **StraightFlash™** at jamba must overlap the **DuPont™ FlexWrap™** at the sill and adhere to the **Tyvek® WRB** apron below the sill.

**OPTIONAL:** If installing a drip cap as part of the window installation, but after the window head flashing, see *Drip Cap Installation* section and refer to [Option 2](#).

## Installation Methods for DuPont Self-Adhered Flashing Products Installed BEFORE the DuPont™ Tyvek® WRB Integral Flanged Adjacent Rectangular Windows (with Less Than 6" of Sheathing/Framing Between Windows)

### Option 2 – When Using DuPont Self-Adhered Flashing Product at Sheathing/Framing Separating Adjacent Windows

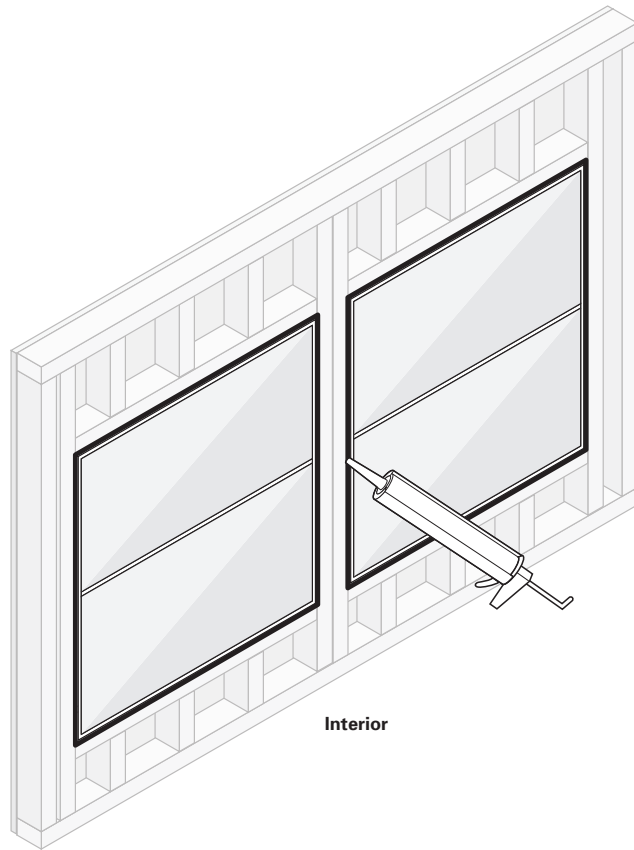

#### STEP 6

Install Tower® Residential Sealant or recommended sealant (and backer rod as necessary) around the window opening at the interior. It is also acceptable to use **Great Stuff Pro™ Window & Door Polyurethane Foam Sealant**, or recommended foam. When using Tower® Residential Sealant, tool sealant bead flat to allow the natural curing process to create a concave shape. Be sure that the sealant penetrates the grooves of the **DuPont™ FlexWrap™** around the sill. When using **Great Stuff Pro™ Window & Door Polyurethane Foam Sealant** in perimeter openings less than 1/2", apply using the plastic extension tip for the **Great Stuff Pro™ Dispensing Gun** during installation.

## Installation Methods for DuPont Self-Adhered Flashing Products Installed BEFORE the DuPont™ Tyvek® WRB Integral Flanged Adjacent Rectangular Windows (with Less Than 6" of Sheathing/Framing Between Windows)

### Option 2 – When Using DuPont Self-Adhered Flashing Product at Sheathing/Framing Separating Adjacent Windows

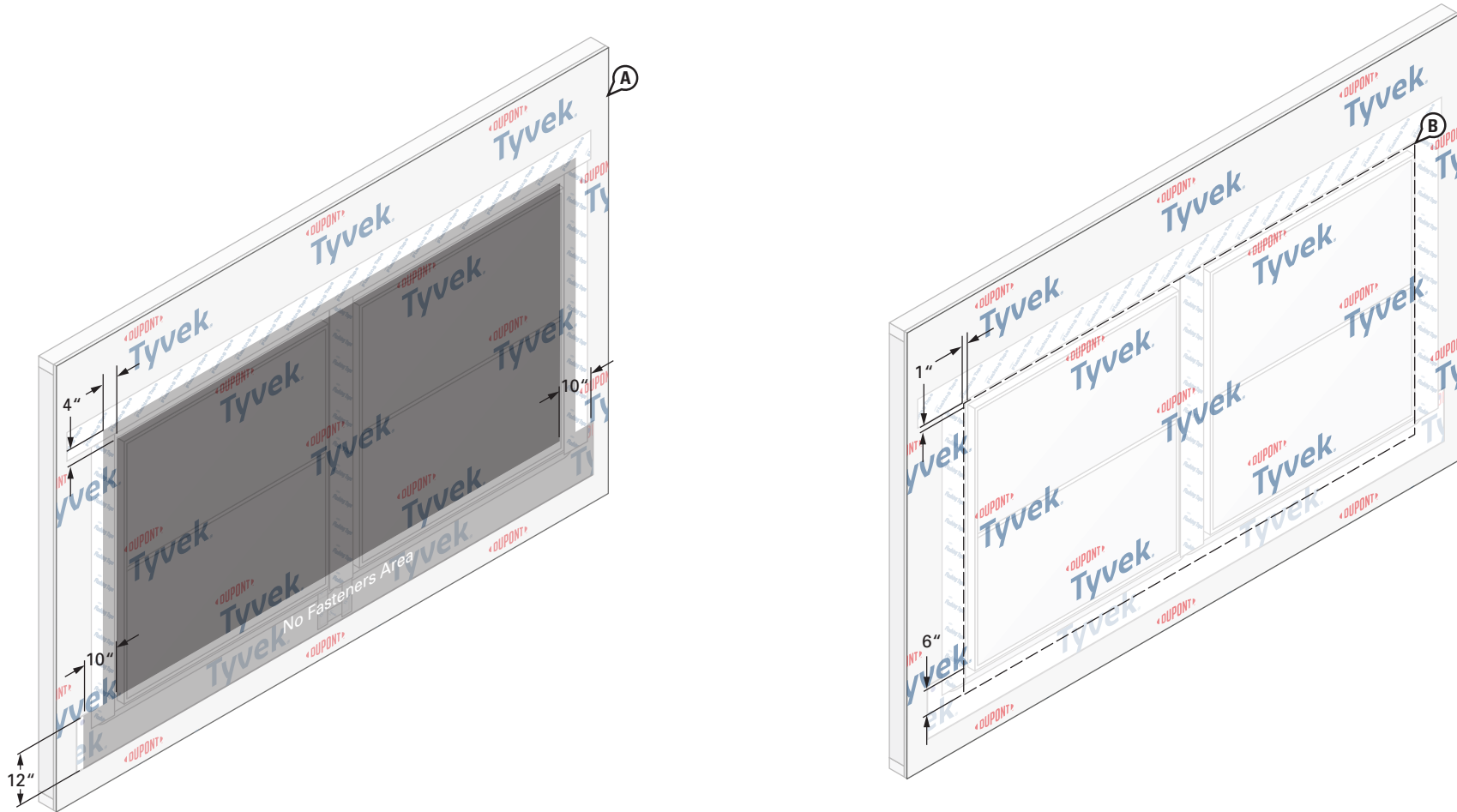

#### STEP 7

A. Install the **Tyvek® WRB** as shown in the [DuPont™ Tyvek® WRB Installation Instructions](#) section of this document. Do not install fasteners within 4" of the window frames at outside jambs and heads and within 12" of the window frames at sills or location of apron.

B. Mark a perimeter on the **Tyvek® WRB** around the rough openings a minimum of 1" from the outside jambs and heads of the window frames, and 6" below the sill of the window frames.

## Installation Methods for DuPont Self-Adhered Flashing Products Installed BEFORE the DuPont™ Tyvek® WRB Integral Flanged Adjacent Rectangular Windows (with Less Than 6" of Sheathing/Framing Between Windows)

### Option 2 – When Using DuPont Self-Adhered Flashing Product at Sheathing/Framing Separating Adjacent Windows

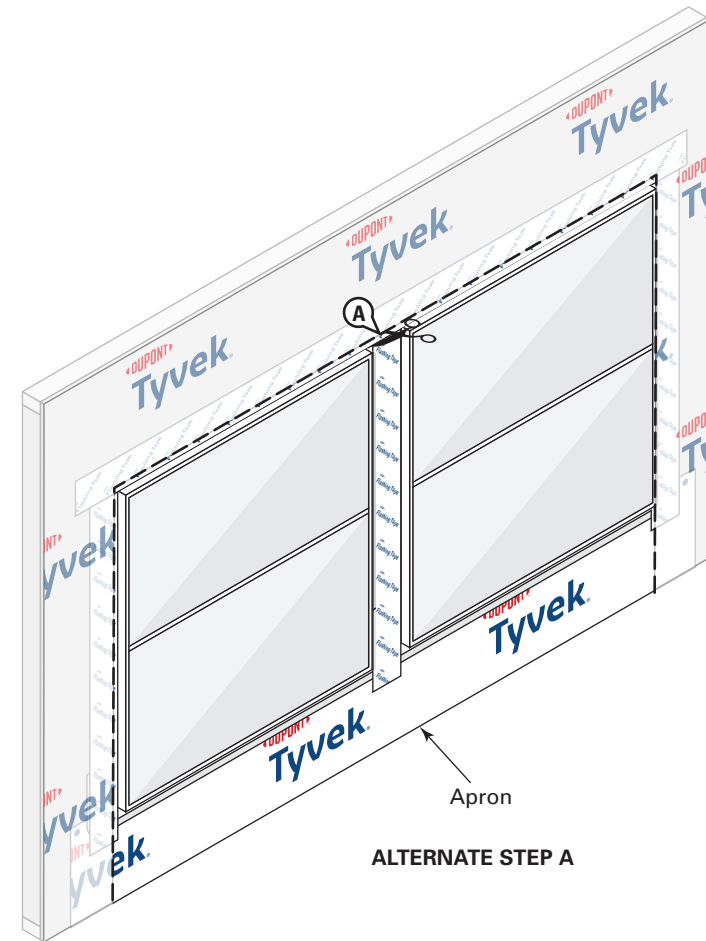
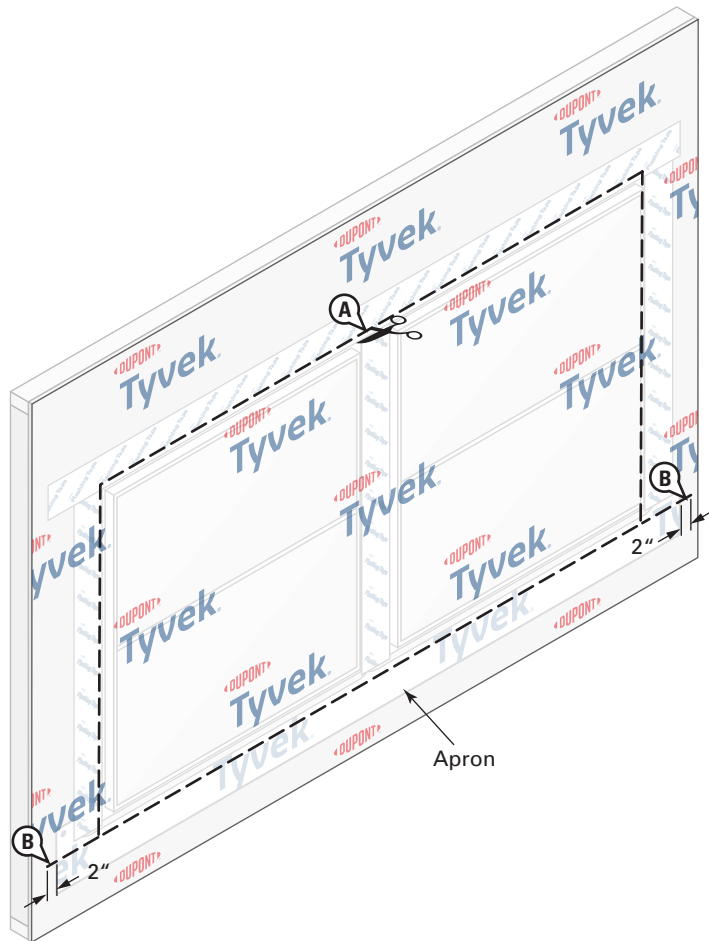

#### STEP 8

- A. Cut the **Tyvek® WRB** along perimeter marking to expose windows. Do not cut through the **DuPont Self-Adhered Flashing Products** or **Tyvek® WRB** apron underneath.
- B. Create horizontal slits in the **Tyvek® WRB** at each lower corner of the perimeter cut that extend 1"– 2" **BEYOND** the **Tyvek® WRB** apron.

**ALTERNATE STEP A:** If apron extends far enough below the sill rough openings to overlap the sill plate, base of wall flashing, or the **Tyvek® WRB** below, the **Tyvek® WRB** can be cut along jambs and head only to overlap apron.

## Installation Methods for DuPont Self-Adhered Flashing Products Installed BEFORE the DuPont™ Tyvek® WRB Integral Flanged Adjacent Rectangular Windows (with Less Than 6" of Sheathing/Framing Between Windows)

### Option 2 – When Using DuPont Self-Adhered Flashing Product at Sheathing/Framing Separating Adjacent Windows

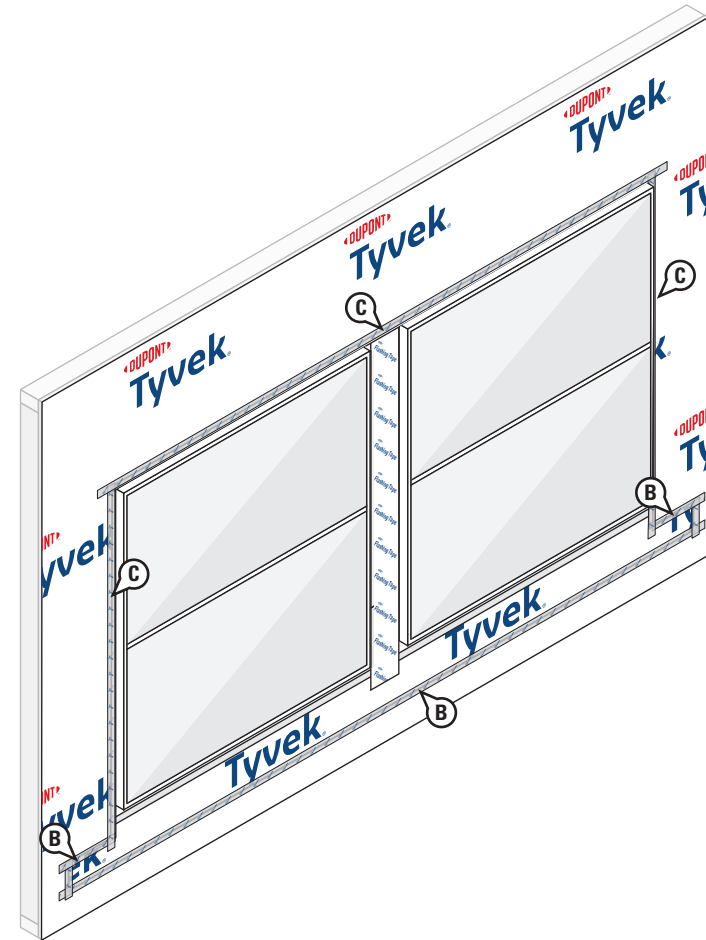
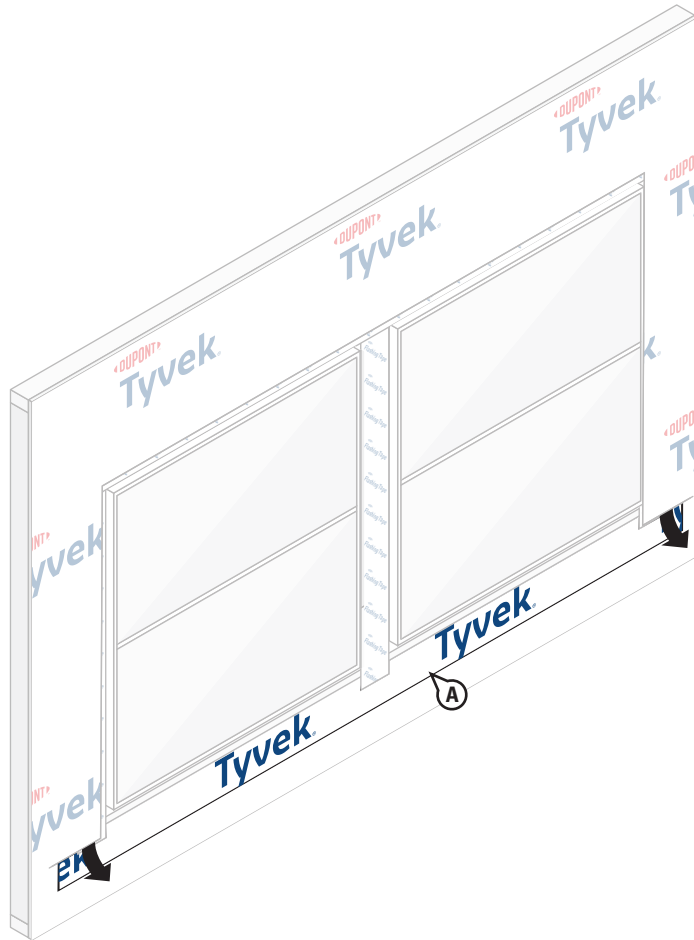

## STEP 9

### Final Step

- A. Bring the bottom portion of the **Tyvek® WRB** apron through the sill perimeter cut and horizontal slits so it laps over the top layer of **Tyvek® WRB**.
- B. Working from bottom to top, install **DuPont™ Tyvek® Tape** to secure horizontal and vertical seams of the **Tyvek® WRB** apron.
- C. Install **Tyvek® Tape** along jambs and head to seal **Tyvek® WRB** around windows. For a more robust termination, **DuPont™ Flashing Tape** or **DuPont™ StraightFlash™** can be used.

**OPTIONAL:** If installing a drip cap **AFTER** the **Tyvek® WRB** is installed and sealed around perimeter of windows, see *Drip Cap Installation* section and refer to [Option 3](#).

## Installation Methods for DuPont Self-Adhered Flashing Products Installed BEFORE the DuPont™ Tyvek® WRB Integral Flanged Door

This installation guideline is intended for doors installed above grade and/or with wood floor construction.

This method applies to the following products: DuPont™ Flashing Tape, DuPont™ FlexWrap™ and DuPont™ StraightFlash™

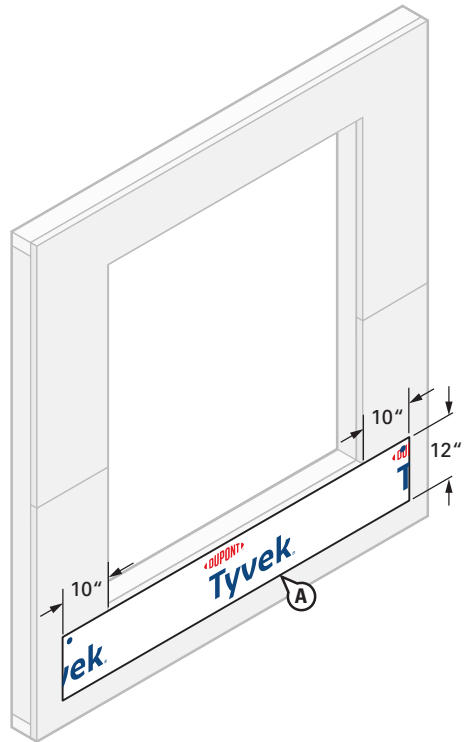

### STEP 1

#### Prepare Tyvek® WRB Apron

- A. Cut an apron made of Tyvek® WRB for attachment under sill of rough opening. Apron should extend at least 10" **BEYOND** the sides of rough opening jambs (or to first stud in open stud construction) and at least 12" below sill of rough opening, or extend far enough below the sill rough opening to overlap the sill plate, base of wall flashing, or the Tyvek® WRB below. The top of the apron should be securely attached to the wall and the bottom of the apron should be left unsecured so it can overlap the Tyvek® WRB which will be installed after the door. Avoid placing DuPont™ Tyvek® Wrap Cap Fasteners where DuPont Self-Adhered Flashing Products will be installed.



## Installation Methods for DuPont Self-Adhered Flashing Products Installed BEFORE the DuPont™ Tyvek® WRB

### Integral Flanged Door

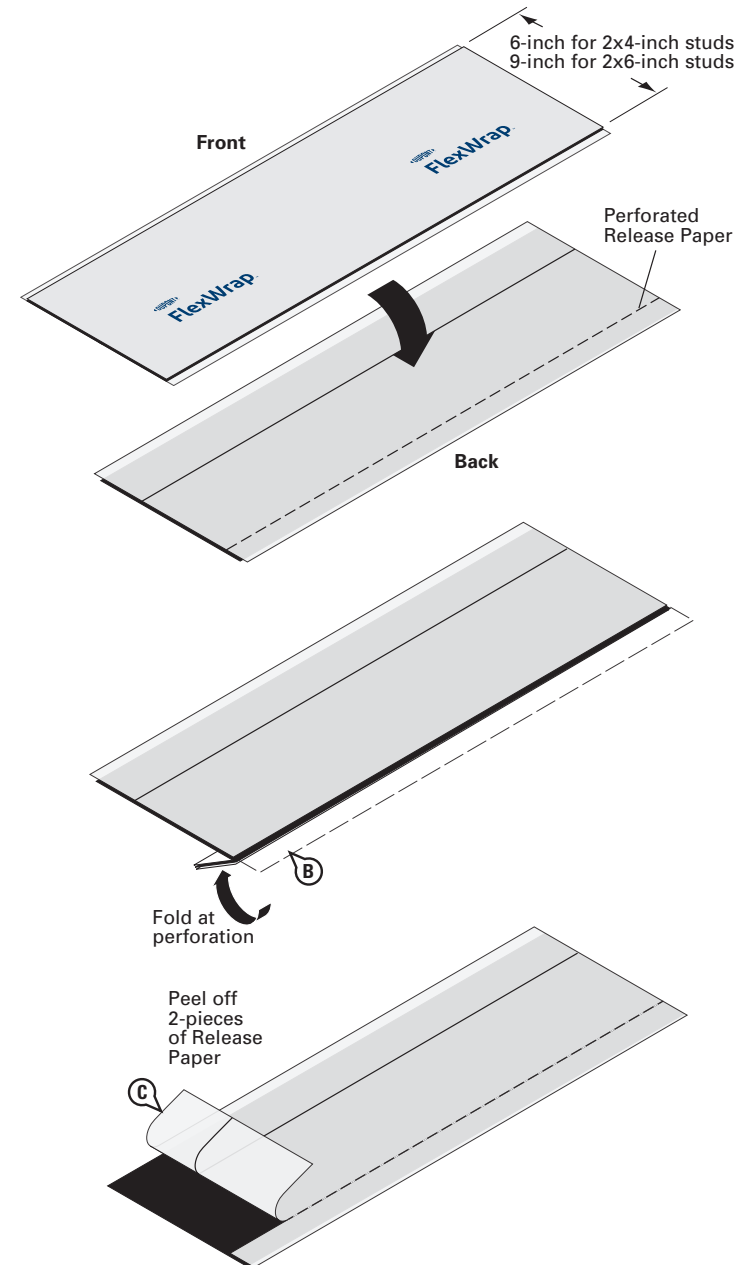
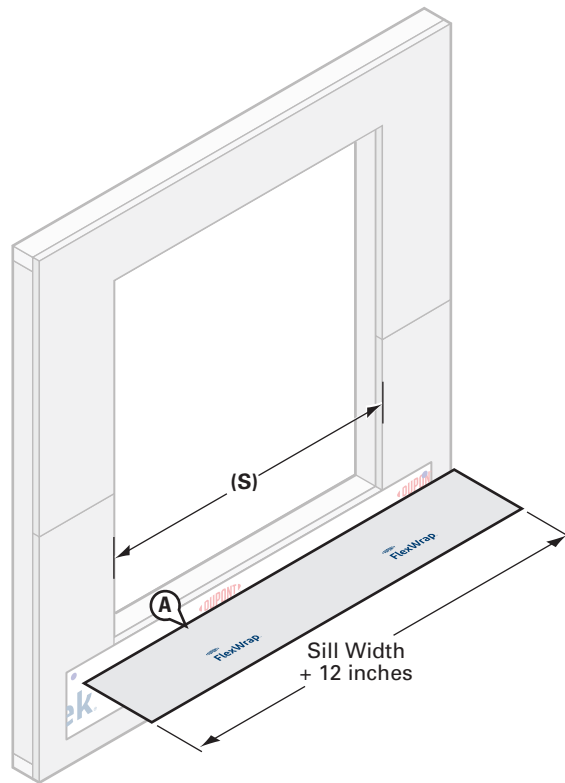

## STEP 2

### Preparation of Sill Flashing

- A. Cut a piece of 9" wide **FlexWrap™** at least 12" **LONGER** than the width of the sill (S).
- B. 9" **FlexWrap™** has perforated release paper to help with the formation of a back dam. To ensure that the perforation tears cleanly, fold the perforation 180° and crease the flashing.
- C. Remove the two widest pieces of release paper leaving the narrowest release paper on the flashing. When the finished floor is applied, the remaining release paper can be removed and the back dam can be completed.

## Installation Methods for DuPont Self-Adhered Flashing Products Installed BEFORE the DuPont™ Tyvek® WRB Integral Flanged Door

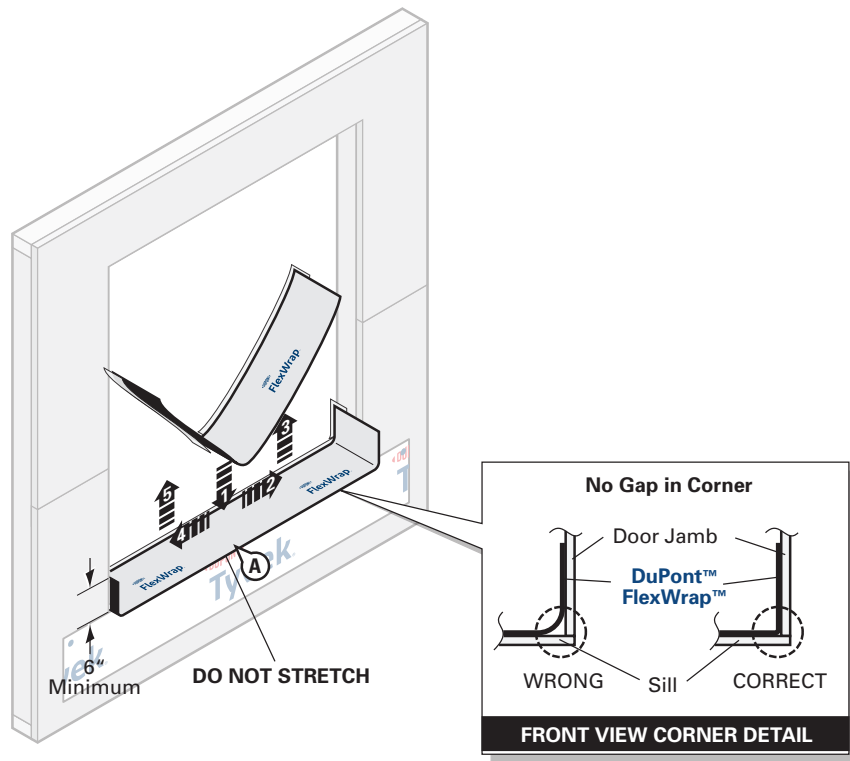

### STEP 3

A. Position the sill flashing as indicated so the section with the release paper still attached extends past the door threshold on the inside. Ensure that 2"– 3" of the **DuPont™ FlexWrap™** will be adhered to the face of the wall with a minimum of 6" up each jamb. Adhere into rough opening. When the narrow release paper is removed, the remaining section of **FlexWrap™** can be used to form a back dam.

**OPTIONAL: Create back dam by folding back narrow section of FlexWrap™.** Some flooring cannot accommodate a back dam. In that case fold the back dam on top of **FlexWrap™** in the sill. The door will be installed on top of the fold to create a back dam (see Side View Detail above).

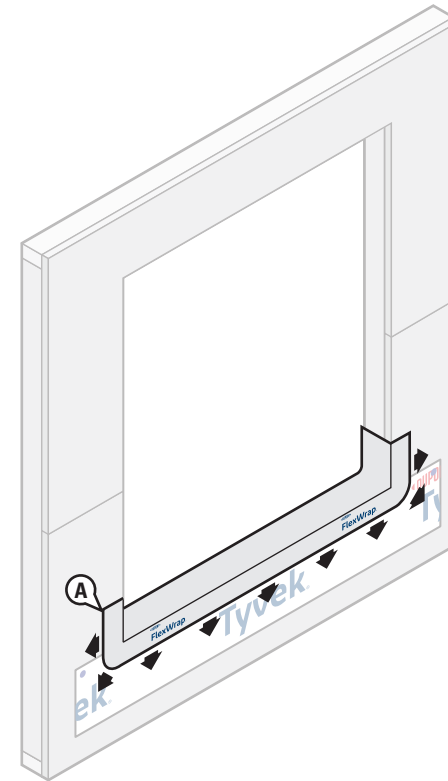

### STEP 4

A. Fan out the **FlexWrap™** at corners and adhere onto face of wall. Continue adhering onto face of wall along sill.

## Installation Methods for DuPont Self-Adhered Flashing Products Installed BEFORE the DuPont™ Tyvek® WRB Integral Flanged Door

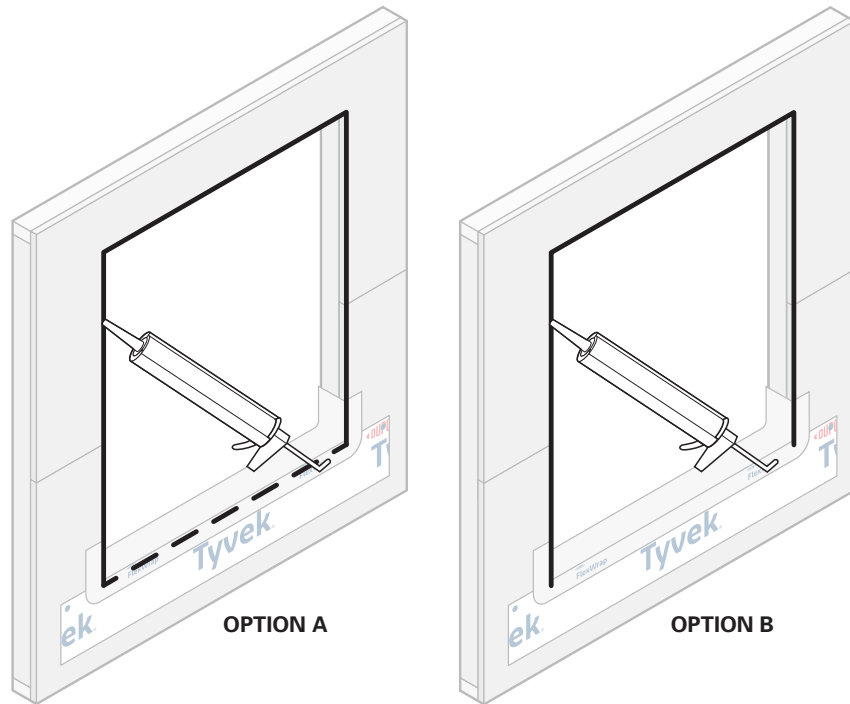

OPTION A

OPTION B

### STEP 5

**OPTION A:** Apply continuous bead of Tower® Residential Sealant, or recommended sealant, at window head and jambs to wall or back side of window mounting flange. **To allow for drainage, do not apply continuous sealant bead along sill.** Ensure a minimum 2" wide drainage gap in the sealant bead within 4" from **each corner** of the jamb-sill interface. Continue applying sealant along the sill with additional 2" wide (min.) drainage gaps for every 6"– 12" (on center) of sill width.

**OPTION B:** Apply continuous bead of Tower® Residential Sealant, or recommended sealant, at window head and jambs to wall or back side of window mounting flange. **To allow for drainage, do not apply sealant bead along sill.**

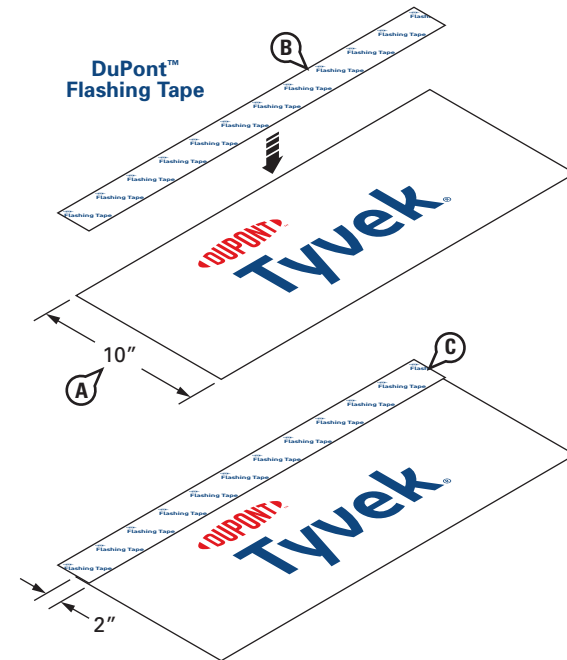

### STEP 6 (OPTIONAL - HIGH PRESSURE SKIRT)

For extreme weather conditions, installation of a high-pressure skirt is recommended to help prevent water intrusion at the sill or threshold.

- Create the high pressure skirt by cutting a piece of **Tyvek® WRB** 1" **WIDER** than the width of door opening and approximately 10" in depth.
- Cut a piece of **DuPont™ Flashing Tape** or **DuPont™ StraightFlash™** to the same width as the skirt.
- Remove release paper and adhere 2" of the exposed butyl to the **Tyvek® WRB**. The skirt may be made with **DuPont™ Flashing Tape**, or **StraightFlash™**, or **DuPont™ VersaFlange™**.

## Installation Methods for DuPont Self-Adhered Flashing Products Installed BEFORE the DuPont™ Tyvek® WRB Integral Flanged Door

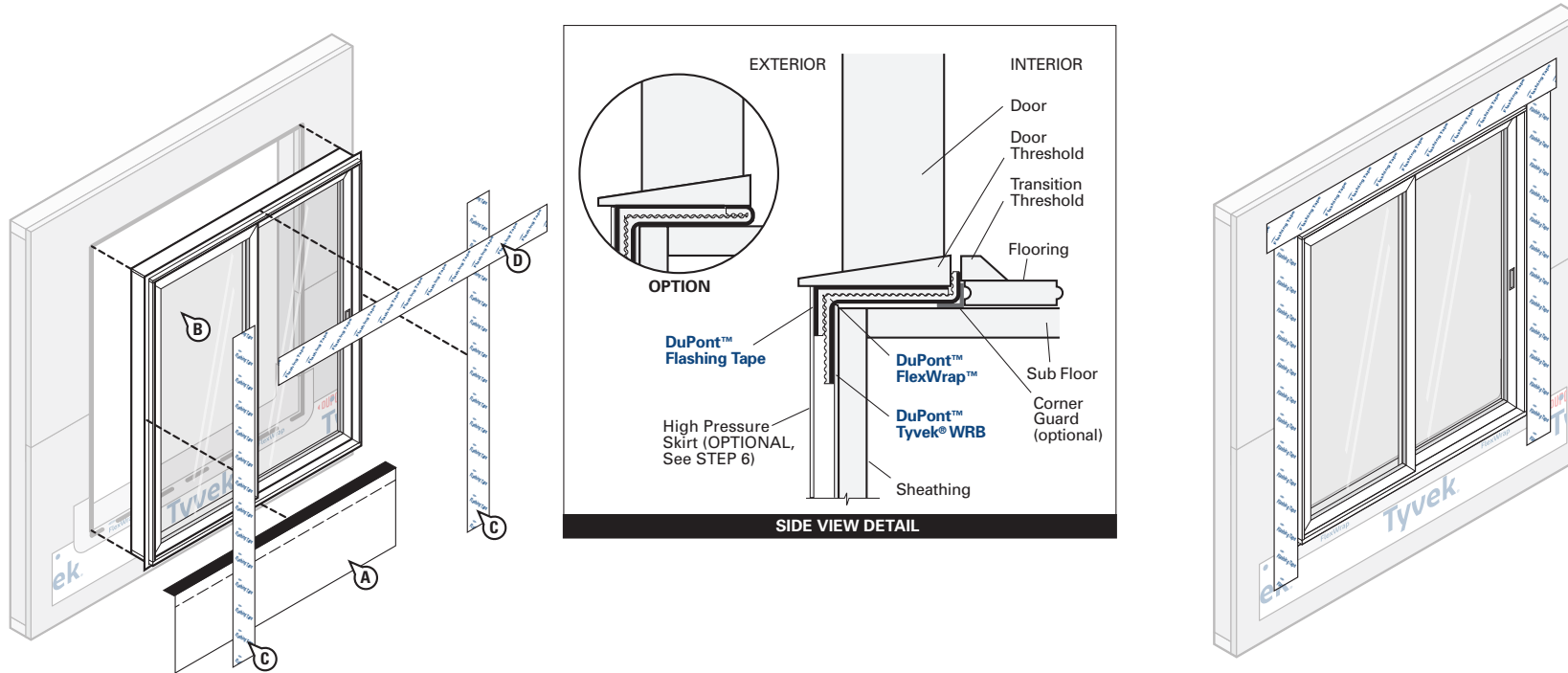

### STEP 7

- A. **OPTIONAL:** Adhere high pressure skirt to bottom of threshold of the door.
- B. Install door according to manufacturer's instructions.
- C. Cut two pieces of **DuPont™ Flashing Tape** or **DuPont™ StraightFlash™** for jamb flashing extending 1" above door head flange and below bottom edge of high pressure skirt. Remove release paper and press tightly along sides of door frame. **OPTIONAL:** If installing a drip cap as part of the door installation before the **DuPont Self-Adhered Flashing** membrane at the door head flange, see *Drip Cap Installation* section and refer to [Option 1](#). **NOTE:** The vertical leg of the drip cap must not be taller than the door head flange when installing drip cap according to [Option 1](#).
- D. Cut a piece of **DuPont™ Flashing Tape** or **StraightFlash™** for head flashing long enough to extend **BEYOND** the outer edges of jamb flashings. Remove release paper and install completely covering mounting flange and adhering to exposed sheathing or framing members. **OPTIONAL:** If installing a drip cap as part of the door installation, but after the door head flashing, see *Drip Cap Installation* section and refer to [Option 2](#).

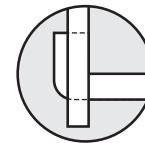

**INCORRECT**  
**DuPont™ FlexWrap™**  
reverse flashed

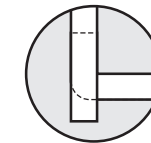

**INCORRECT**  
**DuPont™ Flashing Tape**  
flush with **FlexWrap™**

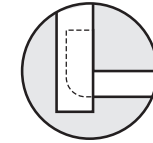

**CORRECT**  
**DuPont™ Flashing Tape**  
overlaps **FlexWrap™**

**NOTE:** Ensure proper shingling. **DuPont™ Flashing Tape** or **StraightFlash™** at jambs must overlap the **DuPont™ FlexWrap™** at the sill and adhere to the **Tyvek® WRB** apron below the sill

## Installation Methods for DuPont Self-Adhered Flashing Products Installed BEFORE the DuPont™ Tyvek® WRB Integral Flanged Door

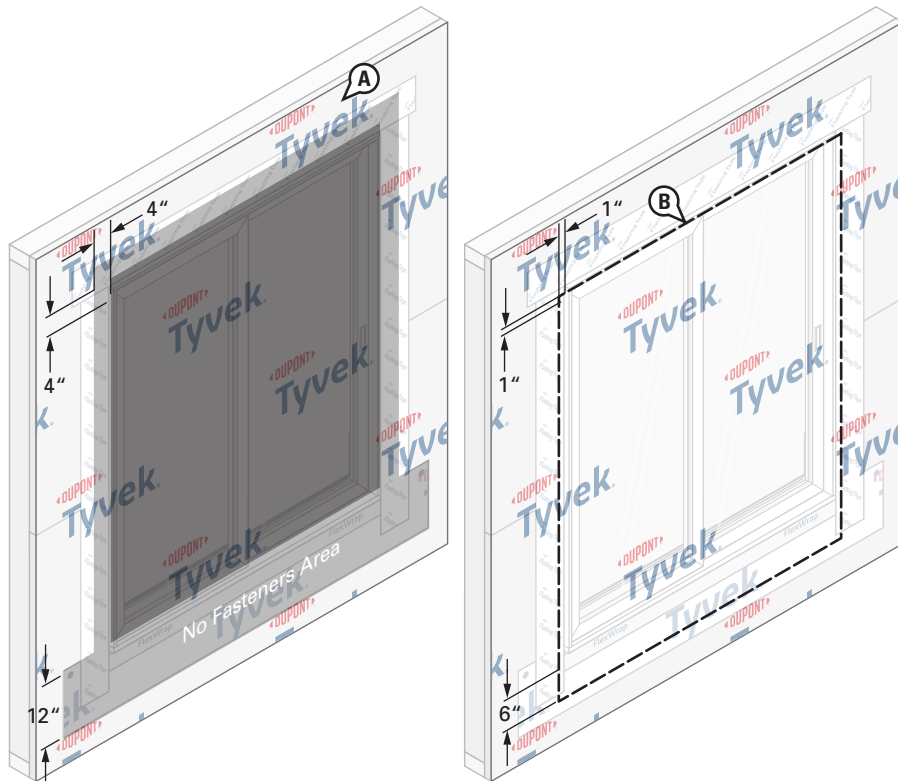

### STEP 8

- A. Install the **Tyvek® WRB** as shown in the [DuPont™ Tyvek® WRB Installation Instructions](#) section of this document. Do not install fasteners within 4" of the door frame at jambs and head and within 12" of the door frame at sill or location of apron.
- B. Mark a perimeter on the **Tyvek® WRB** around the rough opening a minimum of 1" from the jambs and head of the door frame, and 6" below the sill of the door frame.

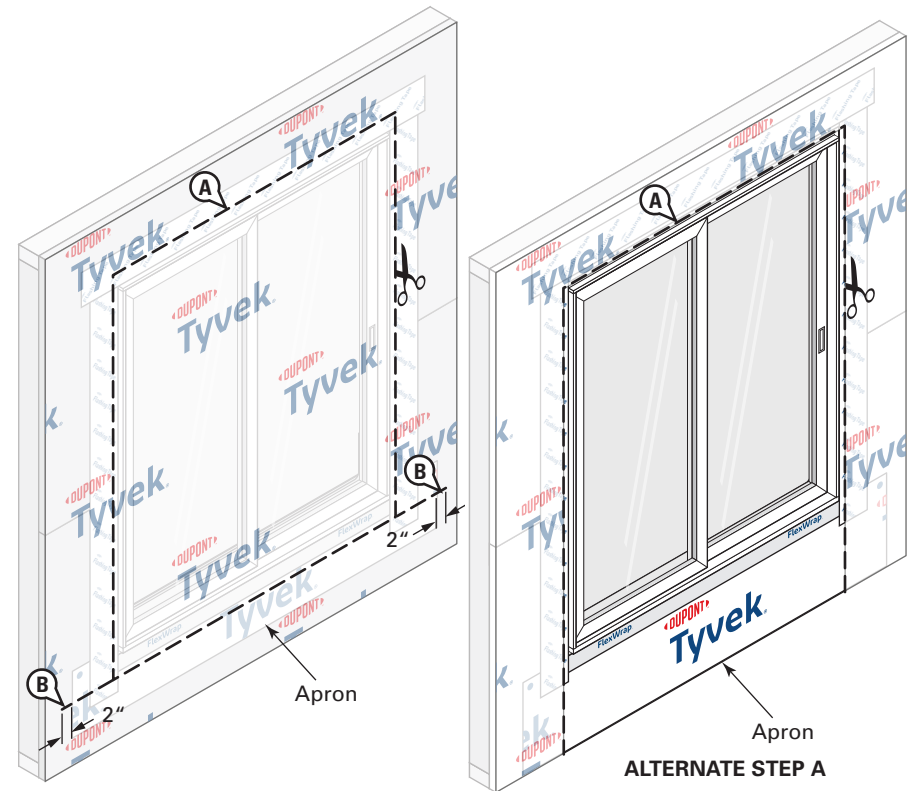

### STEP 9

- A. Cut the **Tyvek® WRB** along perimeter marking to expose door. Do not cut through the **DuPont Self-Adhered Flashing Products** or **Tyvek® WRB** apron underneath.  
**ALTERNATE STEP A:** If apron extends far enough below the sill rough opening to overlap the sill plate, base of wall flashing, or the **Tyvek® WRB** below, the **Tyvek® WRB** can be cut along jambs and head only to overlap apron.
- B. Create horizontal slits in the **Tyvek® WRB** at each lower corner of the perimeter cut that extend 1"– 2" **BEYOND** the **Tyvek® WRB** apron.

## Installation Methods for DuPont Self-Adhered Flashing Products Installed BEFORE the DuPont™ Tyvek® WRB Integral Flanged Door

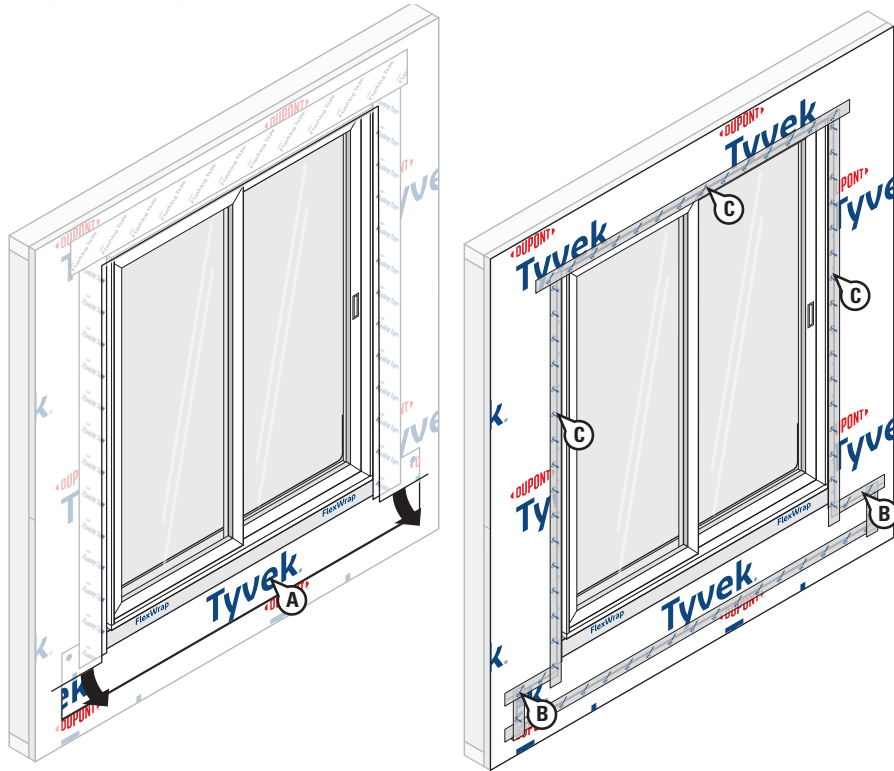

### STEP 10

- Bring the bottom portion of the **Tyvek® WRB** apron through the sill perimeter cut and horizontal slits so it laps over the top layer of **Tyvek® WRB**.
- Working from bottom to top, install **DuPont™ Tyvek® Tape** to secure horizontal and vertical seams of the **Tyvek® WRB** apron.
- Install **Tyvek® Tape** along jambs and head to seal **Tyvek® WRB** around door. For a more robust termination, **DuPont™ Flashing Tape** or **DuPont™ StraightFlash™** can be used.

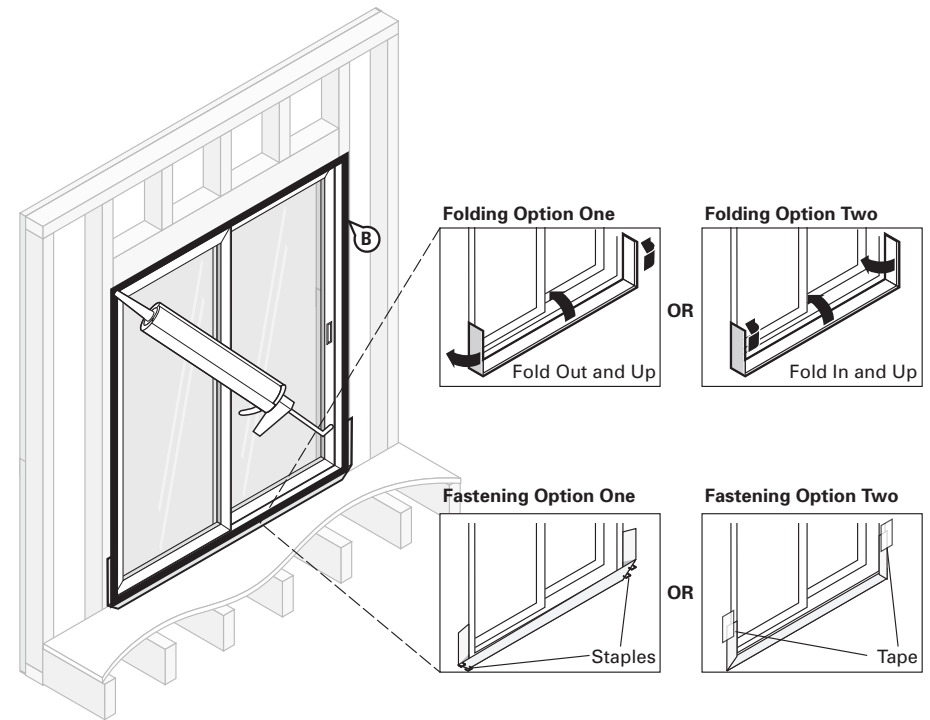

### STEP 11

#### Final Step

- When the interior flooring is ready to install, remove release paper and use Folding Option One or Two (shown above) to form back dam.
- Install Tower® Residential Sealant or recommended sealant (and backer rod as necessary) around the door opening at the interior. It is also acceptable to use **Great Stuff Pro™ Window & Door Polyurethane Foam Sealant**, or recommended foam. When using Tower® Residential Sealant, tool sealant bead flat to allow the natural curing process to create a concave shape. Be sure that the sealant penetrates the grooves of the **DuPont™ FlexWrap™** around the sill. When using **Great Stuff Pro™ Window & Door Polyurethane Foam Sealant** in perimeter openings less than 1/2", apply using the plastic extension tip for the **Great Stuff Pro™ Dispensing Gun** during installation.



## Installation Methods for DuPont Self-Adhered Flashing Products Installed BEFORE the DuPont™ Tyvek® WRB Drip Cap Installation with Integral Flanged Windows and Doors

### Option 1

A drip cap with a short vertical leg can be installed at the window head flange so it is integrated with the **DuPont Self-Adhered Flashing** membrane installed at the head of the window **BEFORE** the **Tyvek® WRB** is installed and sealed. **NOTE:** When using this method, the vertical leg of the drip cap **must not be taller** than the window head flange when installed.

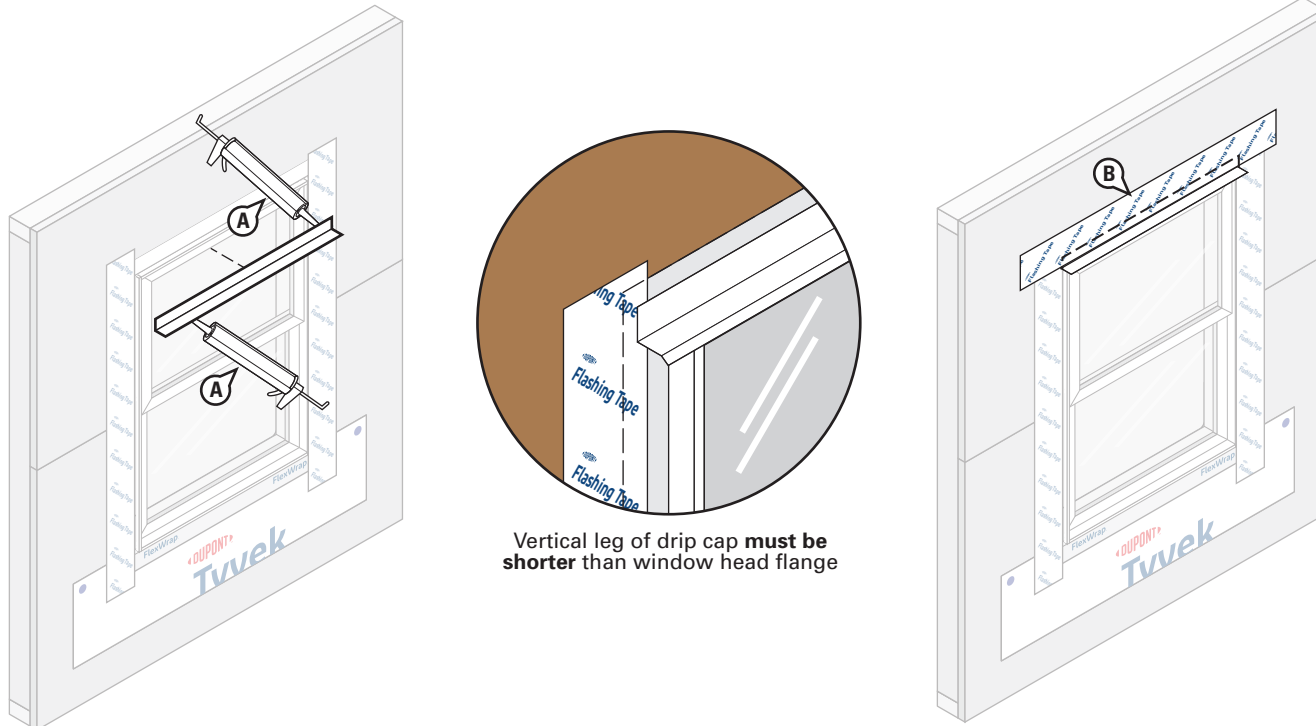

### STEP 1

- A. After the window is installed and jamb flashing applied, cut a piece of metal or vinyl drip cap slightly **LONGER** than the width of the window. Place a bead of Tower® Residential Sealant, or recommended sealant, on the rear side of the vertical leg **AND** a bead on the rear side of the bottom horizontal leg. Install the drip cap tight against the window head flange.
- B. Cover the head flange and top edge of the drip cap with a piece of **DuPont™ Flashing Tape** or **DuPont™ StraightFlash™**. The **DuPont Self-Adhered Flashing Products** should be long enough to extend **BEYOND** the jamb flashing and adhere a minimum of 2" onto the wall.

## Installation Methods for DuPont Self-Adhered Flashing Products Installed **BEFORE** the DuPont™ Tyvek® WRB Drip Cap Installation with Integral Flanged Windows and Doors

Option 1 (continued)

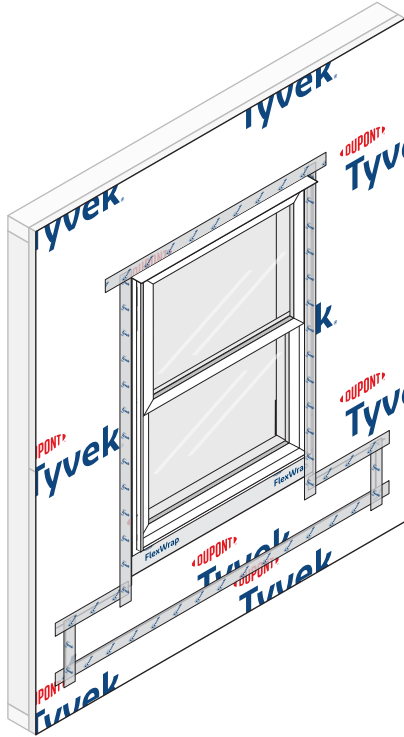

---

### STEP 2

Install the **DuPont™ Tyvek® WRB** according to the [Integral Flanged Window BEFORE DuPont™ Tyvek® WRB](#) section, Steps 6-8.

**NOTE:** The horizontal perimeter cut in the **Tyvek® WRB** at top of window will need to extend slightly **BEYOND** the window frame at jambs to accommodate the drip cap and be sealed onto the vertical leg with **DuPont™ Tyvek® Tape**.

## Installation Methods for DuPont Self-Adhered Flashing Products Installed BEFORE the DuPont™ Tyvek® WRB

### Drip Cap Installation with Integral Flanged Windows and Doors

#### Option 2

A drip cap can be installed over the head flashing above the window head BEFORE the **DuPont™ Tyvek® WRB** is installed and sealed.

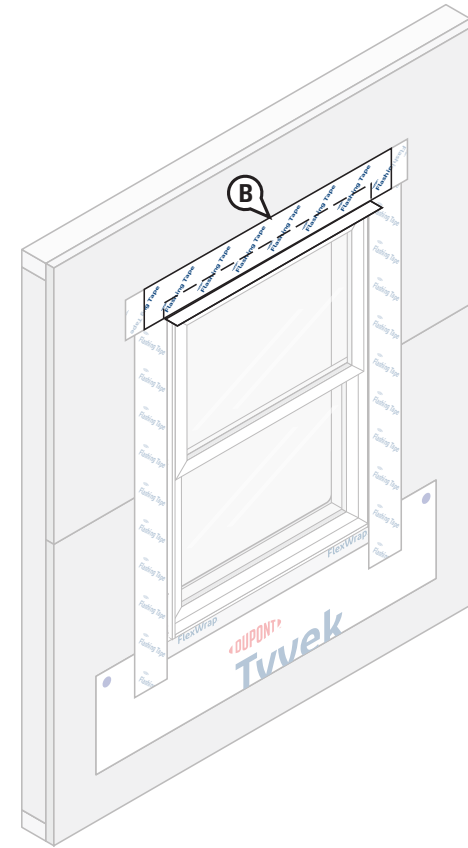
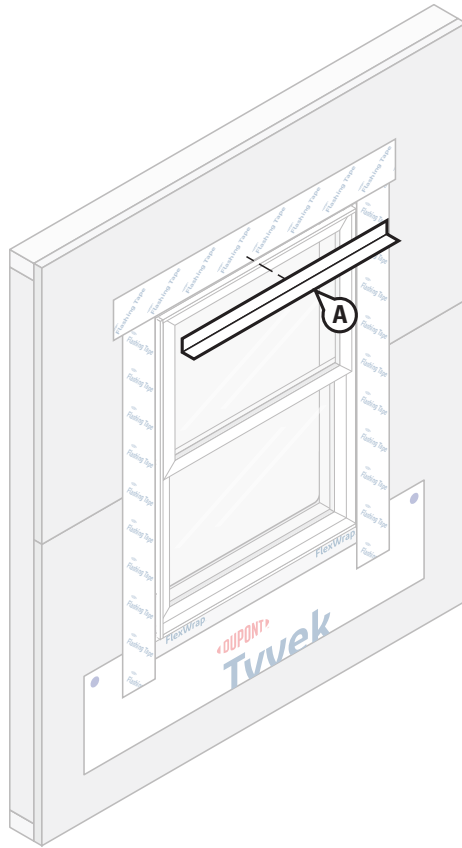

#### STEP 1

A. After the **DuPont™ Flashing Tape** or **DuPont™ StraightFlash™** is installed over window head flange, cut metal or vinyl drip cap slightly **LONGER** than the width of the window.

B. Install the drip cap tight against the window head flashing and cover the top edge with **DuPont™ Flashing Tape** or **StraightFlash™** extending past the top and sides of the drip cap.

## Installation Methods for DuPont Self-Adhered Flashing Products Installed **BEFORE** the DuPont™ Tyvek® WRB Drip Cap Installation with Integral Flanged Windows and Doors

### Option 2 (continued)

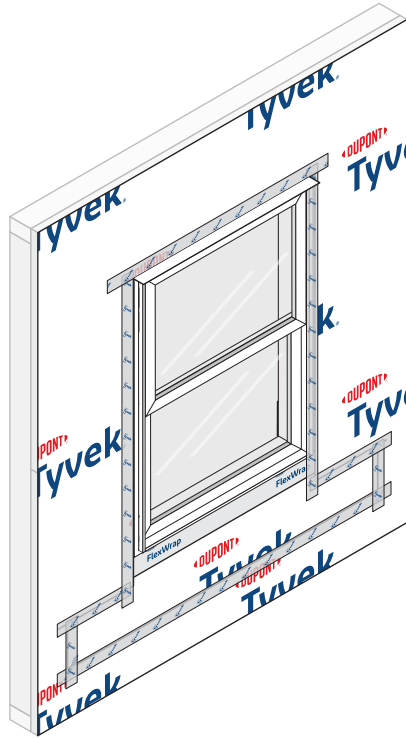

---

### STEP 2

Install the **DuPont™ Tyvek® WRB** according to the [Integral Flanged Window BEFORE DuPont™ Tyvek® WRB](#) section, Steps 6-8.

**NOTE:** The horizontal perimeter cut in the **Tyvek® WRB** at top of window will need to extend slightly **BEYOND** the window frame at jambs to accommodate the drip cap and be sealed onto the vertical leg with **DuPont™ Tyvek® Tape**.

## Installation Methods for DuPont Self-Adhered Flashing Products Installed BEFORE the DuPont™ Tyvek® WRB

### Drip Cap Installation with Integral Flanged Windows and Doors

#### Option 3

A drip cap can be installed over the **DuPont™ Tyvek® WRB** above the window head **AFTER** the **Tyvek® WRB** is installed and sealed.

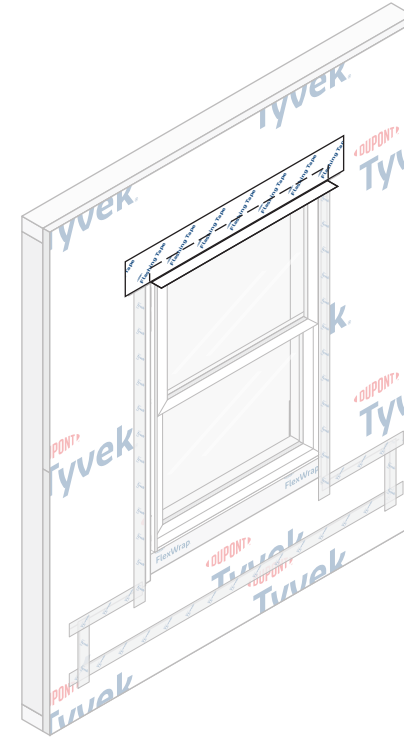
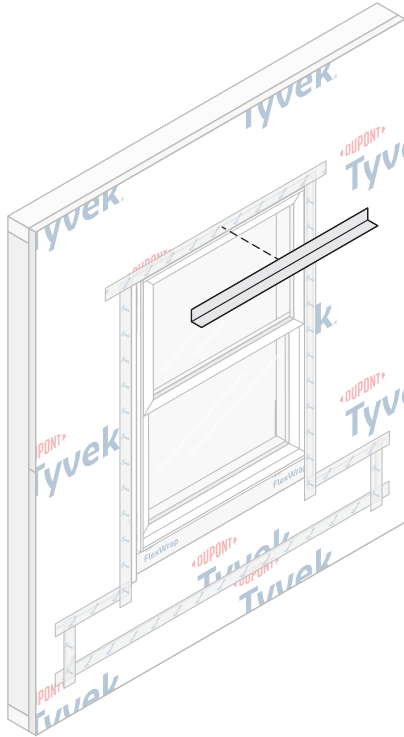

#### STEP 1

A. After **Tyvek® WRB** is installed and sealed, cut metal or vinyl drip cap slightly **LONGER** than the width of the window and install.

B. As a recommended best practice, cover the top edge of the drip cap with **DuPont™ Flashing Tape** or **DuPont™ StraightFlash™** extending past the top and sides of the drip cap and side edges of the window head flashing.

## Installation Methods for DuPont Self-Adhered Flashing Products Installed BEFORE the DuPont™ Tyvek® WRB Non-Flanged Windows and Doors (Using “Wrap the Cavity” Method)

The steps below can be used for the following details: Non-Flanged Window, Non-Flanged Door, Brick Mold Window, Brick Mold Door, Storefront Window on Slab, Storefront Window on Knee Wall, and/or PTAC Units.\*

This method applies to the following products: DuPont™ Flashing Tape, DuPont™ StraightFlash™, and DuPont™ FlexWrap™

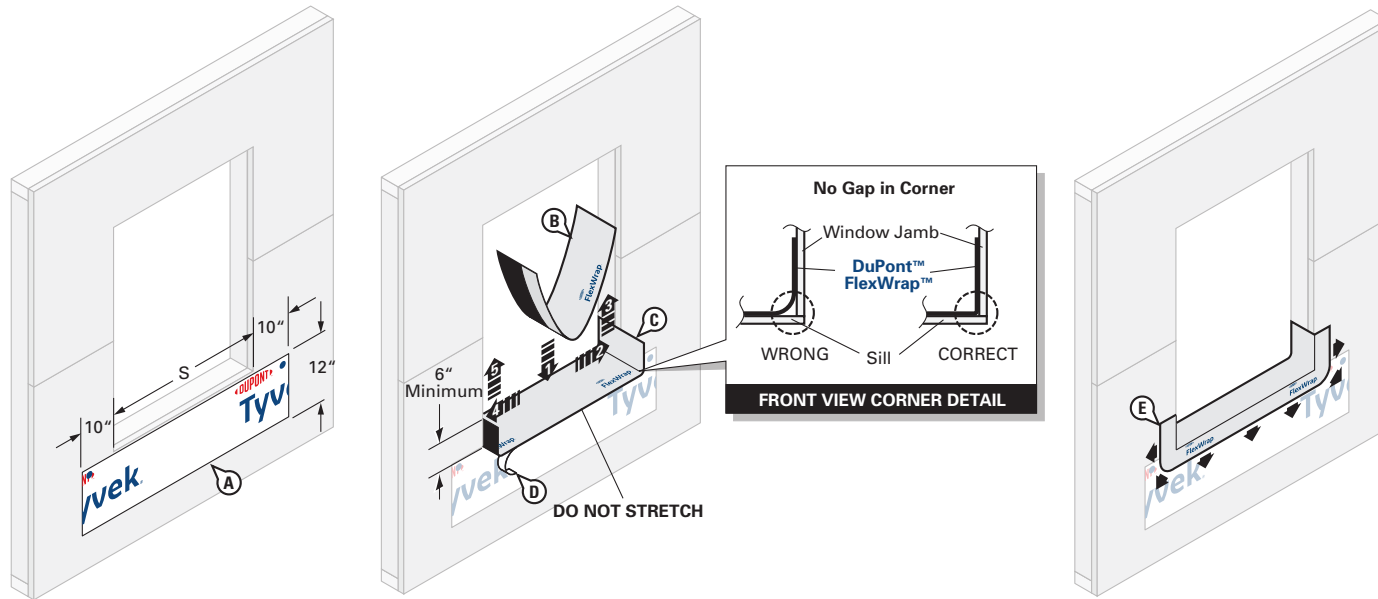

### STEP 1

#### Prepare Tyvek® WRB Apron

- A. Cut an apron made of **Tyvek® WRB** for attachment under sill of rough opening. Apron should extend at least 10" **BEYOND** the sides of rough opening jambs (or to first stud in open stud construction) and at least 12" below sill of rough opening, or extend far enough below the sill rough opening to overlap the sill plate, base of wall flashing, or the **Tyvek® WRB** below. The top of the apron should be securely attached to the wall and the bottom of the apron should be left unsecured so it can overlap the **Tyvek® WRB** which will be installed after the window. Avoid placing **DuPont™ Tyvek® Wrap Cap Fasteners**, or recommended fasteners, where **DuPont Self-Adhered Flashing Products** will be installed.
- B. Cut **FlexWrap™** at least 12" **LONGER** than width of rough opening sill (S). Use roll widths sufficient to achieve a minimum of 1" adhesion **BEYOND** where the window frame will be located, ensuring 2"– 3" adhesion onto the face of the wall.
- C. Remove wide piece of release paper. Position on horizontal sill by aligning the inside edge of the narrow release paper with the face of the wall to ensure 2"– 3" of the **FlexWrap™** will be adhered to the face of the wall with a minimum of 6" up each jamb. Adhere into rough opening.
- D. Remove narrow release paper.
- E. Fan out the **FlexWrap™** at corners and adhere onto face of wall. Continue adhering onto face of wall along sill.

\*NOTE: For installation methods using **DuPont™ VersaFlange™**, the “Wrap the Cavity” method may be used as an alternate flashing method.

NOTE: When using **DuPont™ Flashing Tape** in lieu of **StraightFlash™** for the wrap the cavity method, Tower® Residential Sealant cannot be used as the primary water seal, as it was not designed to be used for non-flanged units. Refer to Chemical Compatibility of Representative Building Sealants and Adhesives/Primers for more information.



## Installation Methods for DuPont Self-Adhered Flashing Products Installed BEFORE the DuPont™ Tyvek® WRB Non-Flanged Windows and Doors (Using “Wrap the Cavity” Method)

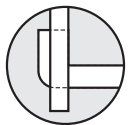
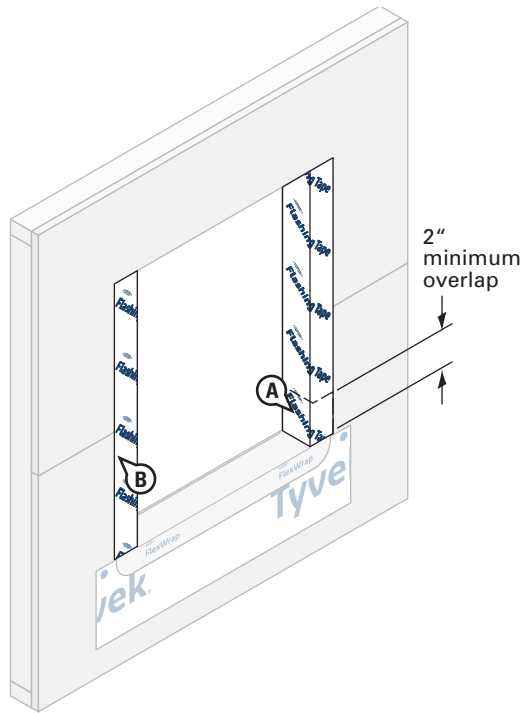

**INCORRECT**  
DuPont™ FlexWrap™  
reverse flashed

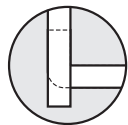

**INCORRECT**  
DuPont™ Flashing Tape  
flush with FlexWrap™

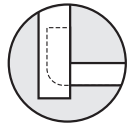

**CORRECT**  
DuPont™ Flashing Tape  
overlaps FlexWrap™

### STEP 2

- A. Cut the jamb flashing the vertical length of the rough opening. Jamb flashing should be long enough to overlap the sill flashing by at least 2” and be overlapped by future head flashing by at least 2”.
- B. Wrap **DuPont™ Flashing Tape** or **DuPont™ StraightFlash™** into the rough opening at each jamb and onto wall face. The flashing should align with the interior edge of the jamb framing.

## Installation Methods for DuPont Self-Adhered Flashing Products Installed BEFORE the DuPont™ Tyvek® WRB Non-Flanged Windows and Doors (Using “Wrap the Cavity” Method)

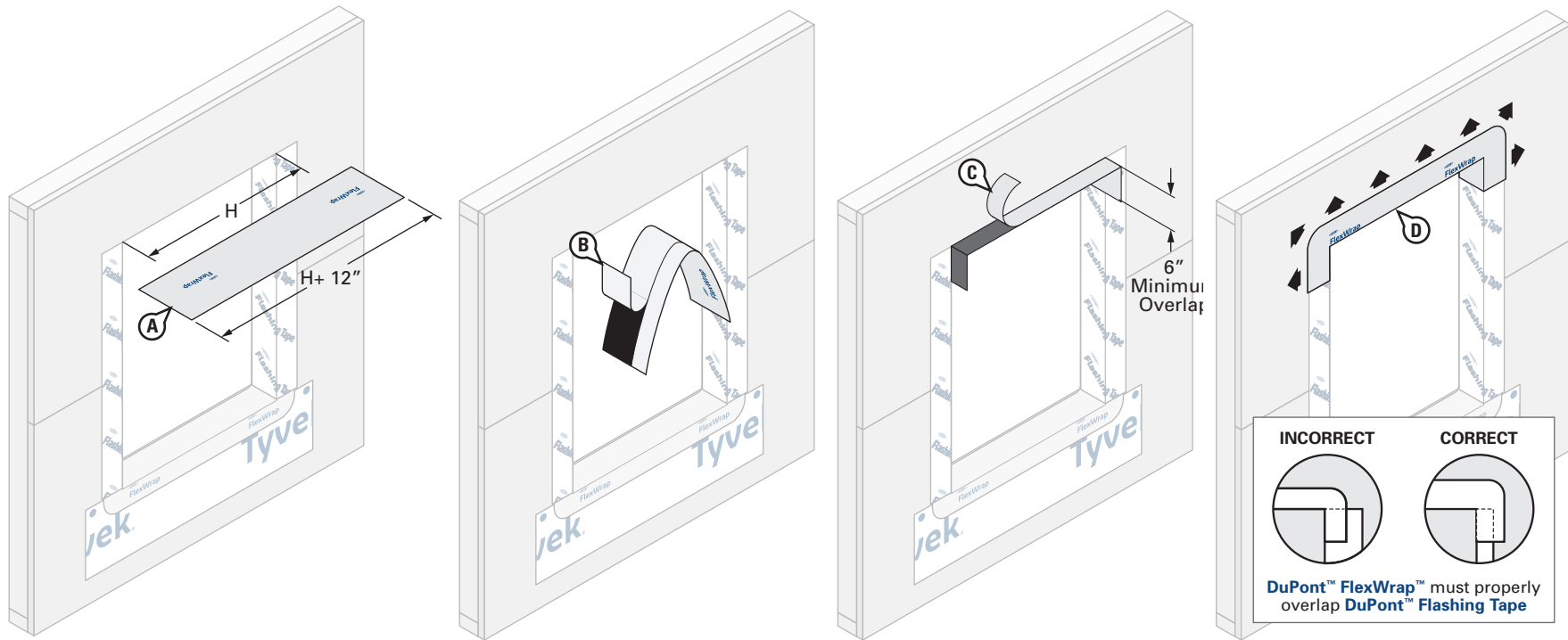

### STEP 3

#### Install DuPont™ FlexWrap™ at Head

- A. Cut **FlexWrap™** at least 12" **LONGER** than width of rough opening head (H). Use roll widths sufficient to achieve a minimum of 1" adhesion **BEYOND** where the window frame will be located, ensuring 2"– 3" adhesion onto the face of the wall.
- B. Fold the **FlexWrap™** in half lengthwise to create a slight crease at the center. Remove the wide piece of release paper on one side of the fold. Align the inside edge of the narrow release paper with the face of the wall to ensure 2"– 3" of the **FlexWrap™** will be adhered to the face of the wall. Starting at the crease, adhere the **FlexWrap™** at the center of the horizontal portion of the head framing to ensure a minimum of 6" down each jamb. Adhere into rough opening at one corner and down the jamb. Remove the remaining release paper, and repeat at opposite corner.
- C. Remove narrow release paper.
- D. Fan out the **FlexWrap™** at corners and adhere onto face of wall. Continue adhering onto face of wall along the head.

**NOTE:** DuPont™ Tyvek® Certified Installers may install a 3-piece head (and sill) detail for window openings less than 6 ft. wide. For windows greater than 6 ft. wide, see the [Special Considerations](#) section for more information regarding the 3-piece head/sill detail. Contact your local DuPont Building Envelope Specialist for more information about the Certified Installer program.

## Installation Methods for DuPont Self-Adhered Flashing Products Installed BEFORE the DuPont™ Tyvek® WRB Non-Flanged Windows and Doors (Using “Wrap the Cavity” Method)

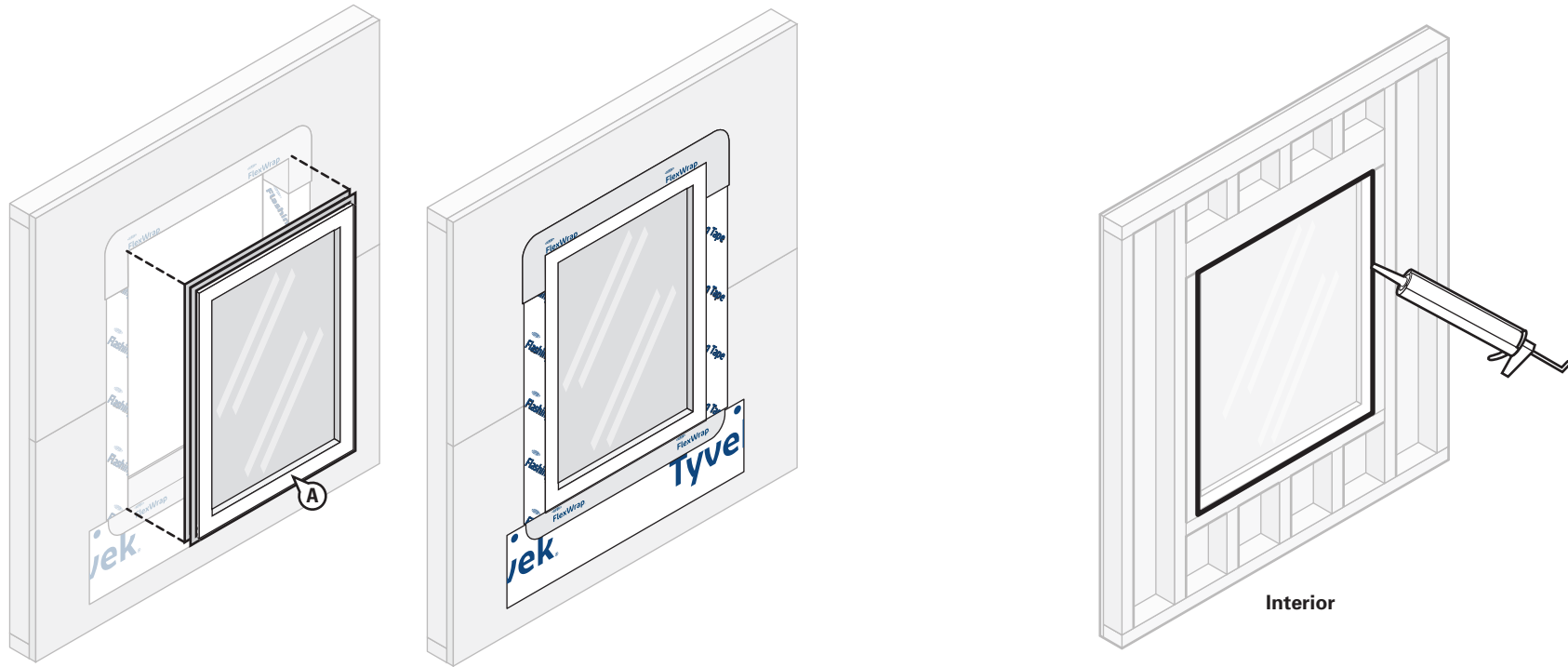

### STEP 4

A. Install window/door per manufacturer’s installation instructions. Apply an exterior perimeter seal using backer rod and sealant along the jambs and head of the window opening.

**NOTE:** Ensure window and sealant installation allows for drainage at the sill. If sealant is applied at the sill, as a best practice, ensure that there are at least two (2) 2” gaps in the sealant bead for every 4” of window to allow for drainage.

### STEP 5

Install recommended sealant\* (and backer rod as necessary) around the window opening at the interior. It is also acceptable to use **Great Stuff Pro™ Window & Door Polyurethane Foam Sealant**, or recommended foam. When using Tower® Residential Sealant, tool sealant bead flat to allow the natural curing process to create a concave shape. Be sure that the sealant penetrates the grooves of the **DuPont™ FlexWrap™** around the sill. When using **Great Stuff Pro™ Window & Door Polyurethane Foam Sealant** in perimeter openings less than 1/2”, apply using the plastic extension tip for the **Great Stuff Pro™ Dispensing Gun** during installation.

**\*NOTE:** If **DuPont™ Flashing Tape** is used to wrap the cavity for non-flanged windows or doors, Tower® Residential Sealant should not be used. Refer to [Chemical Compatibility of Representative Building Sealants and Adhesives/Primers](#) for more information on recommended sealants.

## Installation Methods for DuPont Self-Adhered Flashing Products Installed BEFORE the DuPont™ Tyvek® WRB Non-Flanged Windows and Doors (Using “Wrap the Cavity” Method)

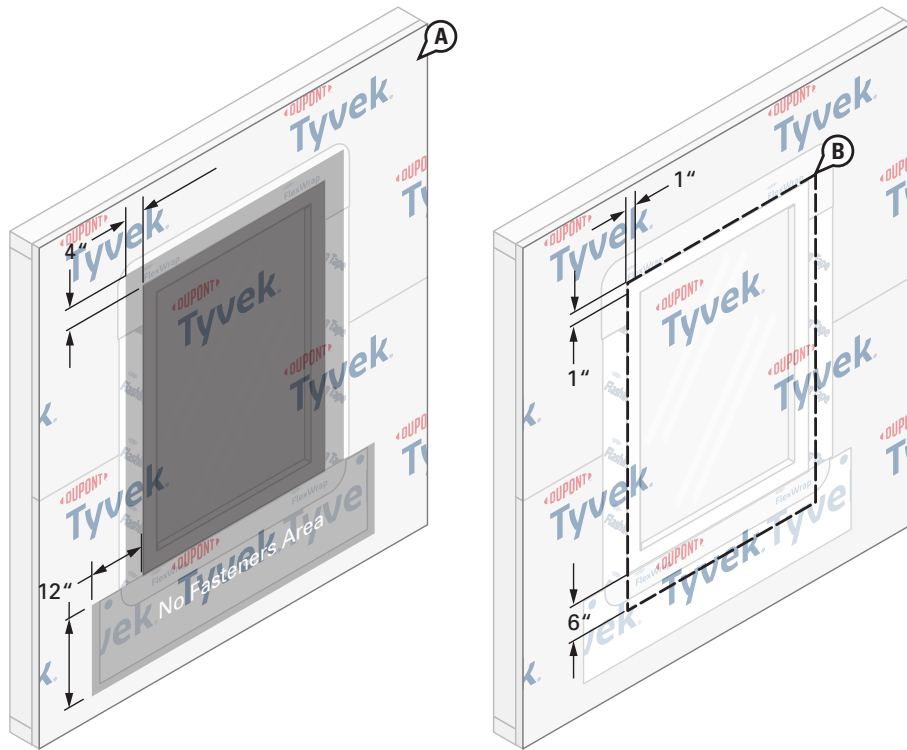

### STEP 6

- Install the **Tyvek® WRB** as shown in the [DuPont™ Tyvek® WRB Installation Instructions](#) section of this document. Do not install fasteners within 4” of the window frame at jambs and head and within 12” of the window frame at sill or location of apron.
- Mark a perimeter on the **Tyvek® WRB** around the rough opening a minimum of 1” from the jambs and head of the window frame, and 6” below the sill of the window frame.

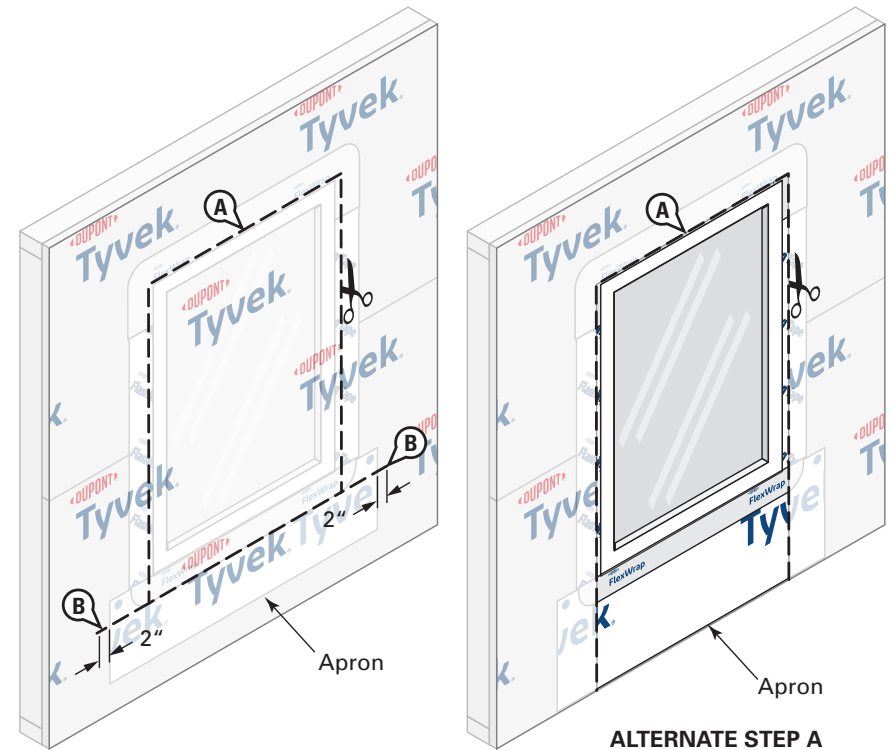

### STEP 7

- Cut the **Tyvek® WRB** along perimeter marking to expose window. Do not cut through the **DuPont Self-Adhered Flashing Products** or **Tyvek® WRB** apron underneath.
- Create horizontal slits in the **Tyvek® WRB** at each lower corner of the perimeter cut that extend 1”– 2” **BEYOND** the **Tyvek® WRB** apron.

**ALTERNATE STEP A:** If apron extends far enough below the sill rough opening to overlap the sill plate, base of wall flashing, or the **Tyvek® WRB** below, the **Tyvek® WRB** can be cut along jambs and head only to overlap apron.

## Installation Methods for DuPont Self-Adhered Flashing Products Installed BEFORE the DuPont™ Tyvek® WRB Non-Flanged Windows and Doors (Using “Wrap the Cavity” Method)

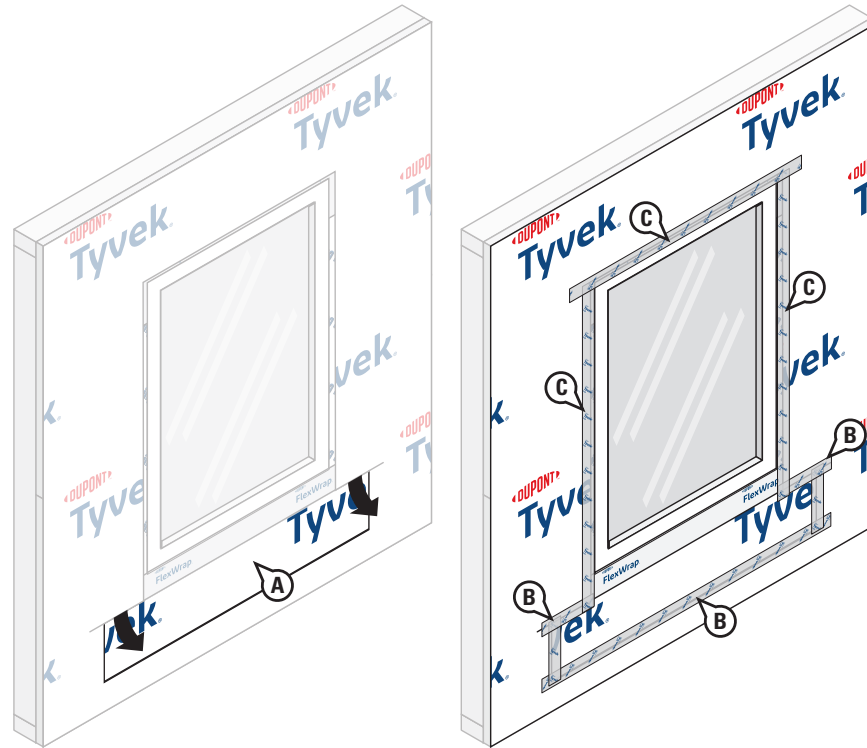

### STEP 8

#### Final Step

- A. Bring the bottom portion of the **Tyvek® WRB** apron through the sill perimeter cut and horizontal slits so it laps over the top layer of **Tyvek® WRB**.
- B. Working from bottom to top, install **DuPont™ Tyvek® Tape** to secure horizontal and vertical seams of the **Tyvek® WRB** apron.
- C. Starting at the jambs and then the head, terminate the **Tyvek® WRB** using **Tyvek® Tape**, **DuPont™ Flashing Tape**, or **DuPont™ StraightFlash™**.

**NOTE:** For a more robust termination, seal with **DuPont™ Flashing Tape** or **StraightFlash™**.

**OPTIONAL:** If installing a drip cap **AFTER** the **Tyvek® WRB** is installed and sealed, see *Drip Cap Installation* section and refer to [Option 3](#).

## Installation Methods for DuPont Self-Adhered Flashing Products Installed BEFORE the DuPont™ Tyvek® WRB

### Non-Flanged Window Using DuPont™ VersaFlange™

Ensure **VersaFlange™** logo side faces the exterior. Use of **VersaFlange™** requires a smooth-framed window for proper adhesion to the frame.

This method applies to the following products: **DuPont™ Flashing Tape**, **DuPont™ StraightFlash™**, **DuPont™ VersaFlange™**, **DuPont™ FlexWrap™**, and **DuPont™ FlexWrap™ EZ**

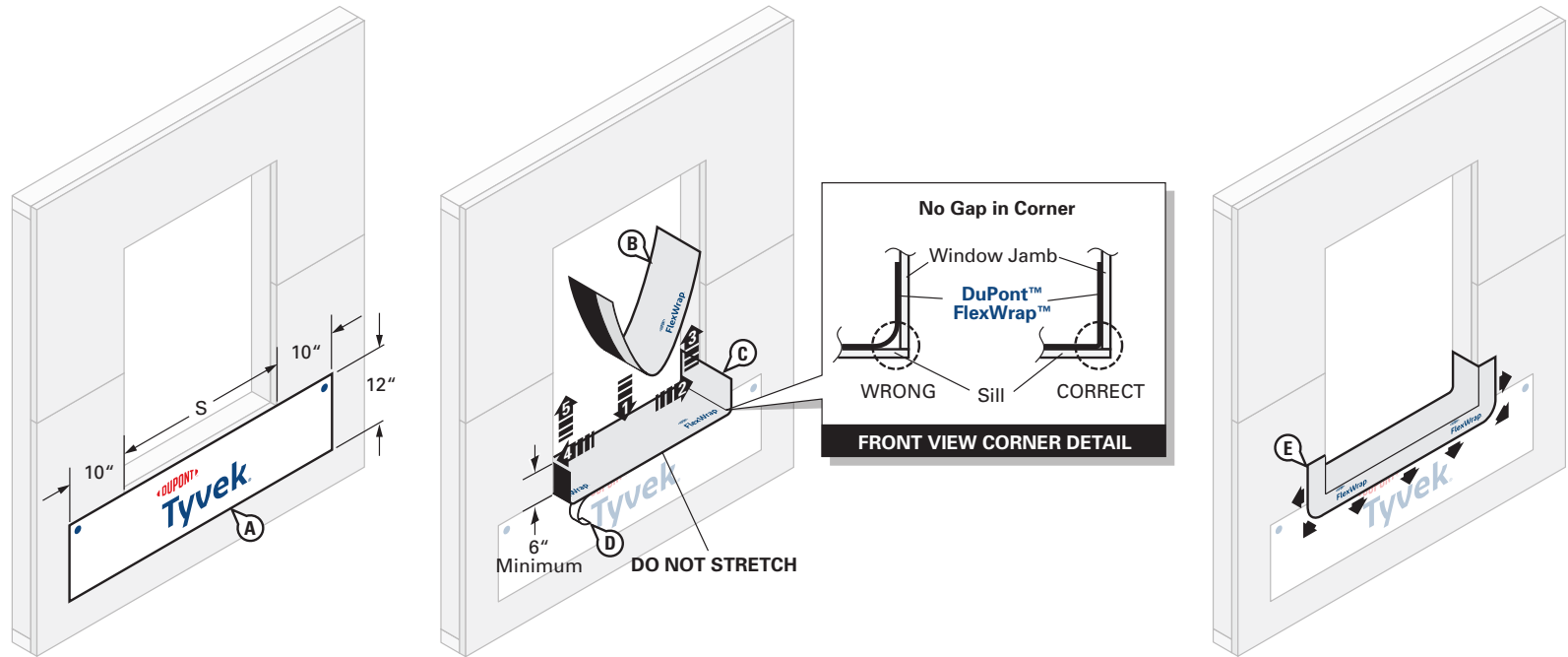

## STEP 1

- Cut an apron made of **Tyvek® WRB** for attachment under sill of rough opening. Apron should extend at least 10" **BEYOND** the sides of rough opening jambs (or to first stud in open stud construction) and at least 12" below sill of rough opening, or extend far enough below the sill rough opening to overlap the sill plate, base of wall flashing, or the **Tyvek® WRB** below. The top of the apron should be securely attached to the wall and the bottom of the apron should be left unsecured so it can overlap the **Tyvek® WRB** which will be installed after the window. Avoid placing **DuPont™ Tyvek® Wrap Cap Fasteners** where **DuPont Self-Adhered Flashing Products** will be installed.
- Cut **FlexWrap™** at least 12" **LONGER** than width of rough opening sill (S). Use roll widths sufficient to achieve a minimum of 1" adhesion **BEYOND** where the window frame will be located, ensuring 2"- 3" adhesion onto the face of the wall.
- Remove wide piece of release paper. Position on horizontal sill by aligning the inside edge of the narrow release paper with the face of the wall to ensure 2"- 3" of the **FlexWrap™** will be adhered to the face of the wall with a minimum of 6" up each jamb. Adhere into rough opening.
- Remove narrow release paper.
- Fan out the **FlexWrap™** at corners and adhere onto face of wall. Continue adhering onto face of wall along sill.



## Installation Methods for DuPont Self-Adhered Flashing Products Installed BEFORE the DuPont™ Tyvek® WRB Non-Flanged Window Using DuPont™ VersaFlange™

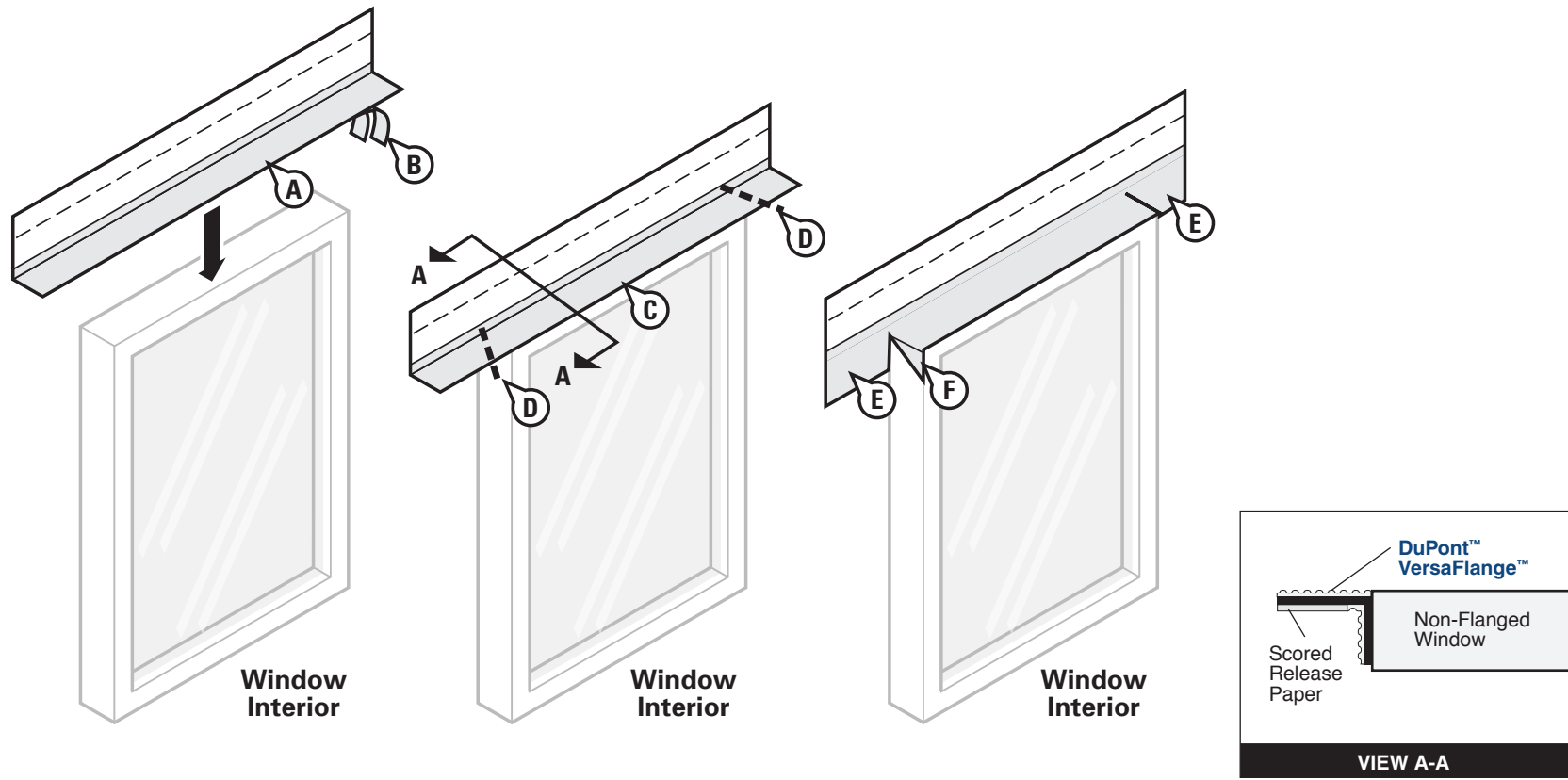

### STEP 2

- Prepare head flashing by cutting a piece of **DuPont™ VersaFlange™** at least 12" **LONGER** than the head length.
- Remove the release paper from one side of the **VersaFlange™**.
- Center the **VersaFlange™** along the length of the window and position so that it contacts the window frame.
- Beginning at the junction of the jamb and head and away from the corners, cut the **VersaFlange™** at a 45° angle.
- Fold the newly created flashing flaps down parallel to the window frame.
- Fold remaining head flashing flaps down onto the jamb.

## Installation Methods for DuPont Self-Adhered Flashing Products Installed BEFORE the DuPont™ Tyvek® WRB Non-Flanged Window Using DuPont™ VersaFlange™

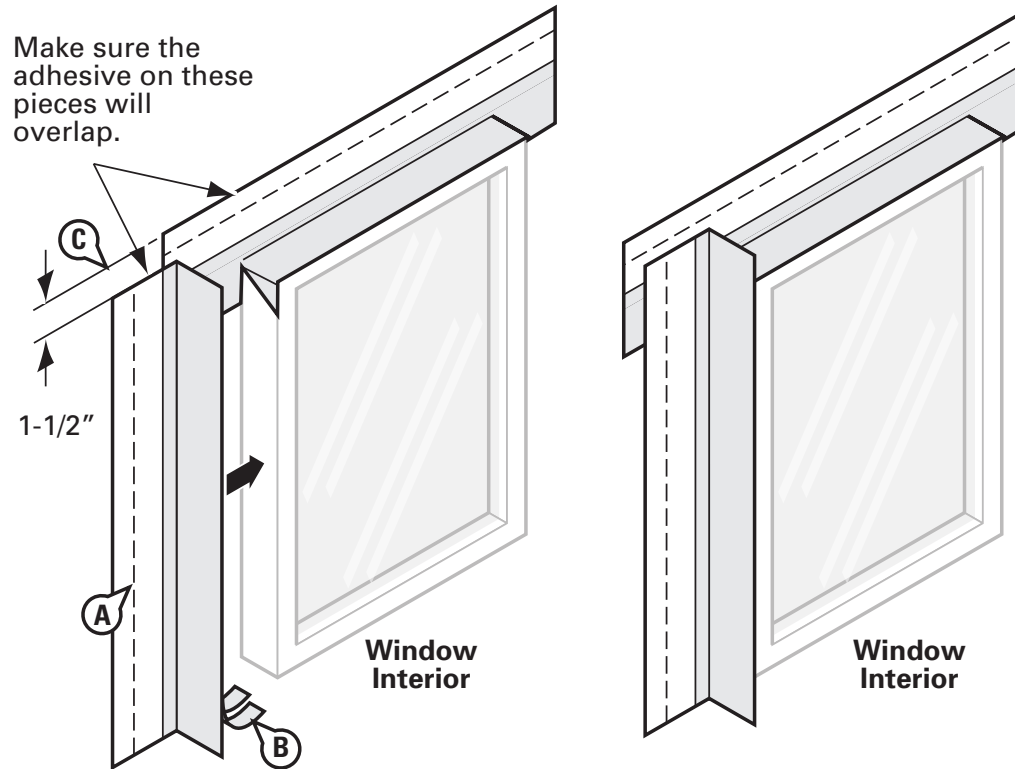

### STEP 3

- Prepare jamb flashing by cutting a piece of **DuPont™ VersaFlange™** at least 6" **LONGER** than the jamb length.
- Remove the release paper from one side of the **VersaFlange™**.
- Position the **VersaFlange™** so that it contacts the window frame up to the exterior face of the window. Ensure that the jamb flashing is positioned 1-1/2" below top of head flashing. **Jamb flashing adhesive must come in contact with head flashing adhesive and overlap by 1"**.
- Repeat on opposite jamb.

## Installation Methods for DuPont Self-Adhered Flashing Products Installed BEFORE the DuPont™ Tyvek® WRB Non-Flanged Window Using DuPont™ VersaFlange™

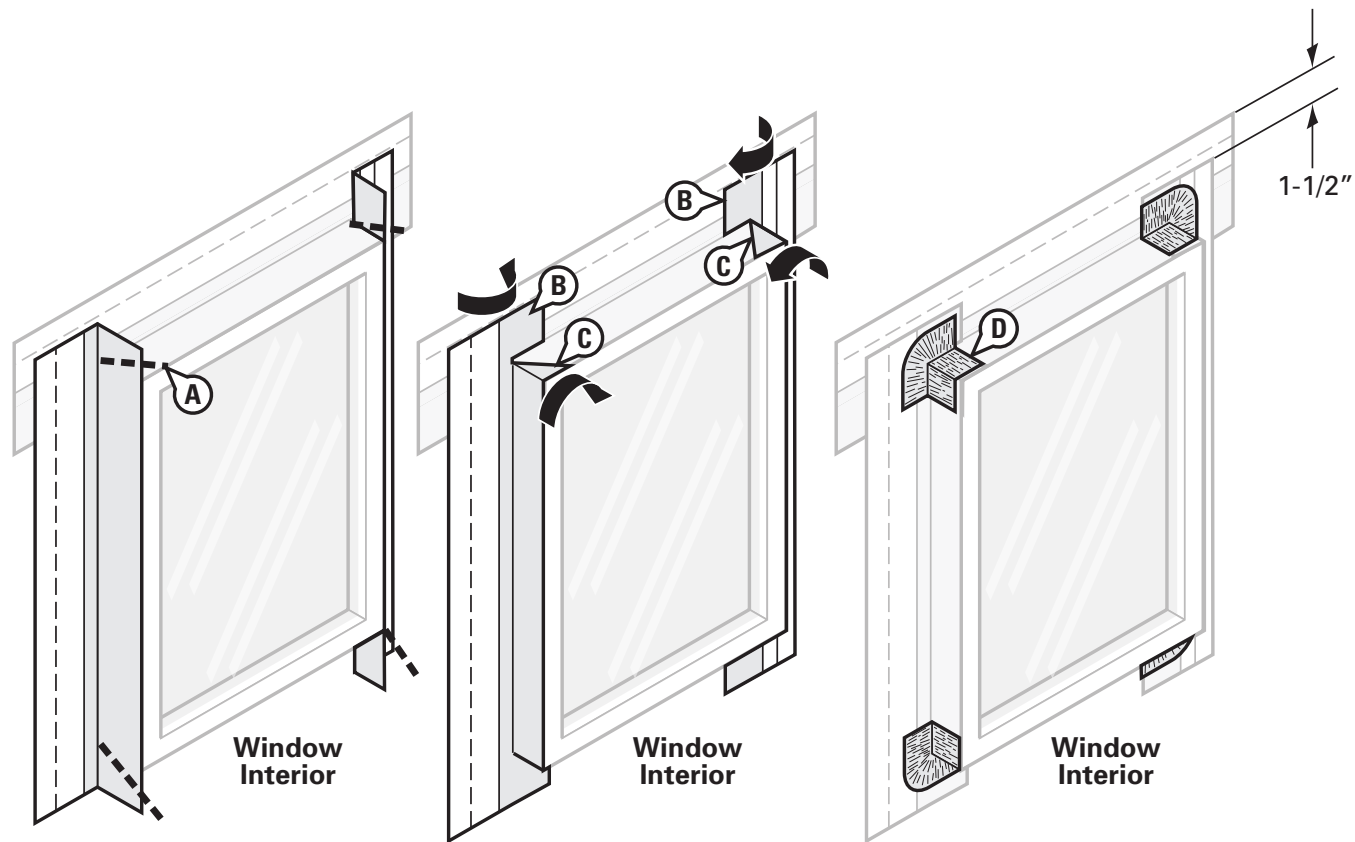

### STEP 4

- A. Beginning at the junction of the jambs and the head, and away from the corners, cut the **DuPont™ VersaFlange™** at a 45° angle. Repeat the procedure at the junction of the sill and jambs.
- B. In order to overlap jamb adhesive to the head flashing adhesive, temporarily pull back release liner on the head flashing. Fold cut jamb flashing parallel to the window frame so that the jamb flashing lies flat onto the head flashing. Fold the head flashing release liner back down to protect any remaining exposed butyl along the head flashing prior to installation of the window.
- C. Fold remaining jamb flashing flaps down at all corners and adhere to the window frame.
- D. Cut four 3" x 3" pieces of **DuPont™ FlexWrap™** or four 3" pieces of **DuPont™ FlexWrap™ EZ** and add patches to corners of the window.

## Installation Methods for DuPont Self-Adhered Flashing Products Installed BEFORE the DuPont™ Tyvek® WRB Non-Flanged Window Using DuPont™ VersaFlange™

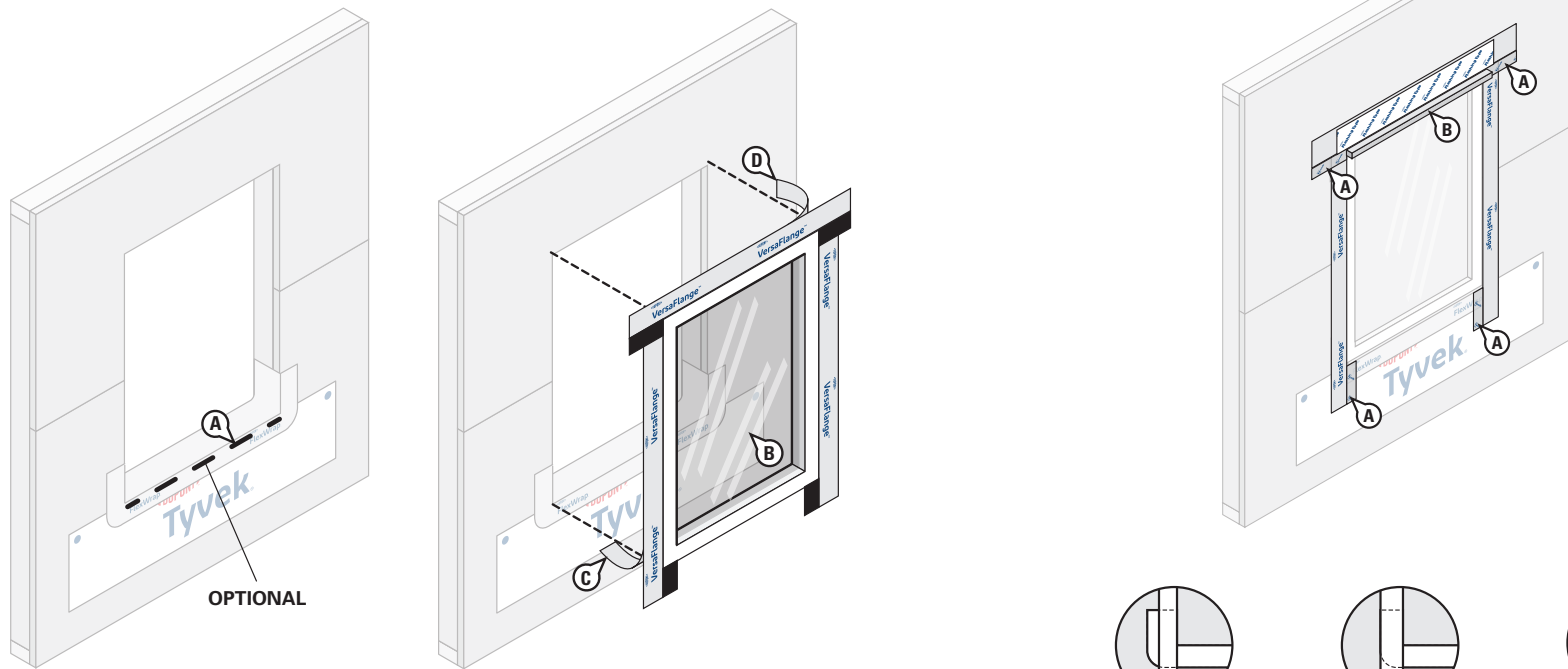

### STEP 5

- A. **OPTIONAL:** Apply Tower® Residential Sealant, or recommended sealant, along the sill as shown above. **To allow for drainage, do not apply continuous sealant bead along sill.** Ensure a minimum 2" wide drainage gap in the sealant bead within 4" from **each corner** of the jamb-sill interface. Continue applying sealant along the sill with additional 2" wide (min.) drainage gaps for every 6"– 12" (on center) of sill width.
- B. Install window according to manufacturer's installation instructions.
- C. Remove the remaining release paper from the **DuPont™ VersaFlange™** jamb flashing and press firmly to adhere the butyl adhesive to the exterior sheathing or framing members. **Do not reverse shingle. VersaFlange™** must overlap **DuPont™ FlexWrap™** and adhere to the substrate.
- D. Remove the release paper at the head and adhere the **VersaFlange™** to the exterior sheathing or framing members.

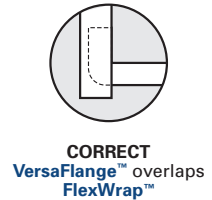
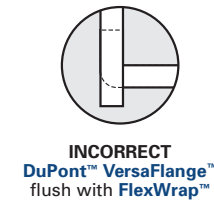

### STEP 6

- A. **OPTIONAL:** Cover exposed butyl with **DuPont™ Tyvek® Tape**, **DuPont™ Flashing Tape**, or **DuPont™ StraightFlash™**.
- B. **OPTIONAL:** If installing a drip cap as part of the window installation **BEFORE** the **Tyvek® WRB** is installed and sealed, see *Drip Cap Installation* section and refer to [Option 2](#).

## Installation Methods for DuPont Self-Adhered Flashing Products Installed BEFORE the DuPont™ Tyvek® WRB Non-Flanged Window Using DuPont™ VersaFlange™

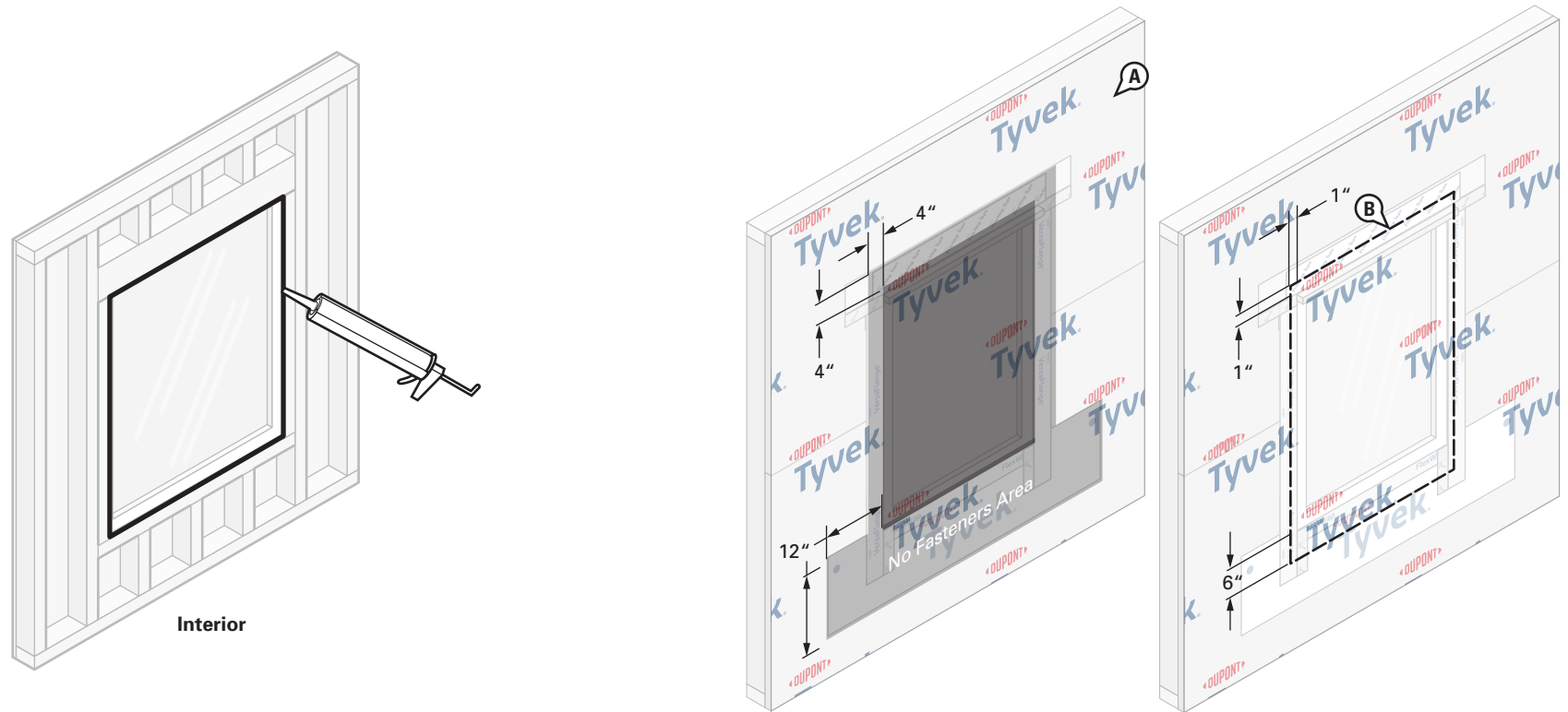

### STEP 7

Install Tower® Residential Sealant or recommended sealant (and backer rod as necessary) around the window opening at the interior. It is also acceptable to use **Great Stuff Pro™ Window & Door Polyurethane Foam Sealant**, or recommended foam. When using Tower® Residential Sealant, tool sealant bead flat to allow the natural curing process to create a concave shape. Be sure that the sealant penetrates the grooves of the **DuPont™ FlexWrap™** around the sill. When using **Great Stuff Pro™ Window & Door Polyurethane Foam Sealant** in perimeter openings less than 1/2", apply using the plastic extension tip for the **Great Stuff Pro™ Dispensing Gun** during installation.

### STEP 8

- Install the **Tyvek® WRB** as shown in the [DuPont™ Tyvek® WRB Installation Instructions](#) section of this document. Do not install fasteners within 4" of the window frame at jambs and head and within 12" of the window frame at sill or location of apron.
- Mark a perimeter on the **Tyvek® WRB** around the rough opening a minimum of 1" from the jambs and head of the window frame, and 6" below the sill of the window frame.

## Installation Methods for DuPont Self-Adhered Flashing Products Installed BEFORE the DuPont™ Tyvek® WRB Non-Flanged Window Using DuPont™ VersaFlange™

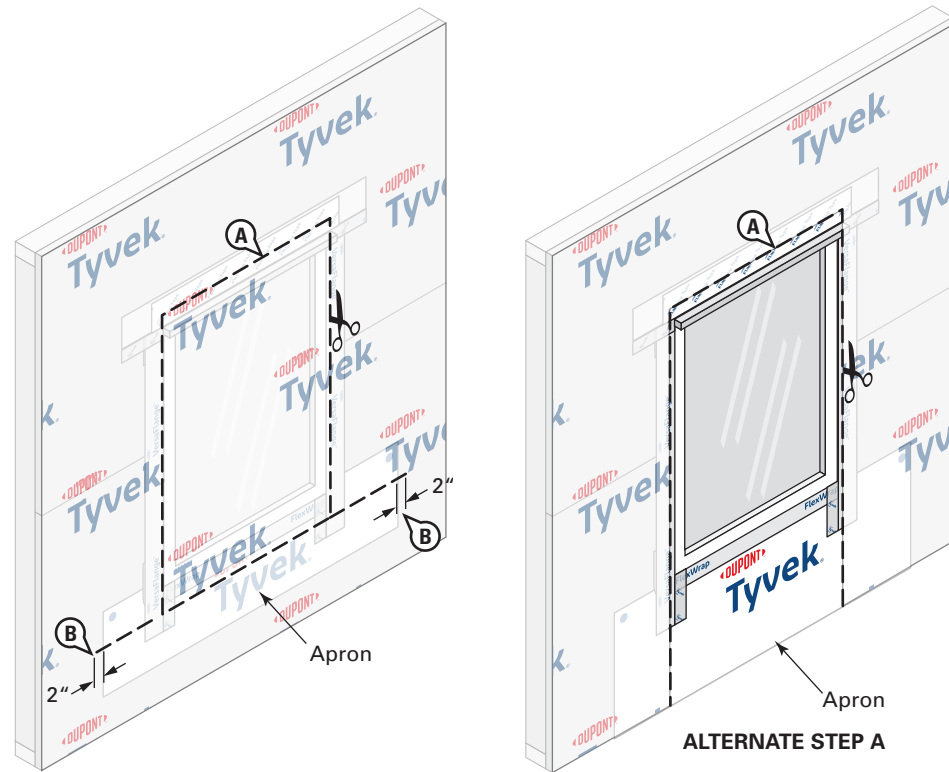

### STEP 9

- A. Cut the **Tyvek® WRB** along perimeter marking to expose window. Do not cut through the **DuPont Self-Adhered Flashing Products** or **Tyvek® WRB** apron underneath.
- B. Create horizontal slits in the **Tyvek® WRB** at each lower corner of the perimeter cut that extend 1"– 2" **BEYOND** the **Tyvek® WRB** apron.

**ALTERNATE STEP A:** If apron extends far enough below the sill rough opening to overlap the sill plate, base of wall flashing, or the **Tyvek® WRB** below, the **Tyvek® WRB** can be cut along jambs and head only to overlap apron.

## Installation Methods for DuPont Self-Adhered Flashing Products Installed BEFORE the DuPont™ Tyvek® WRB Non-Flanged Window Using DuPont™ VersaFlange™

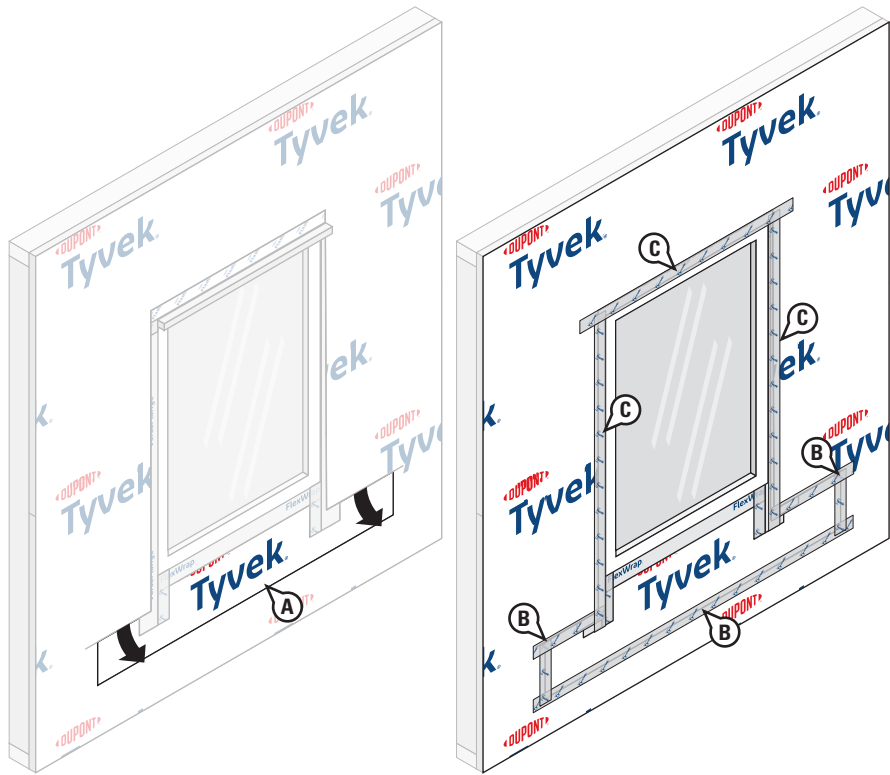

### STEP 10

#### Final Step

- A. Bring the bottom portion of the **Tyvek® WRB** apron through the sill perimeter cut and horizontal slits so it laps over the top layer of **Tyvek® WRB**.
- B. Working from bottom to top, install **DuPont™ Tyvek® Tape** to secure horizontal and vertical seams of the **Tyvek® WRB** apron.
- C. Install **Tyvek® Tape** along jamb and head to seal **Tyvek® WRB** around window. For a more robust termination, **DuPont™ Flashing Tape** or **DuPont™ StraightFlash™** can be used. **OPTIONAL:** If installing a drip cap **AFTER** the **Tyvek® WRB** is installed and sealed, see *Drip Cap Installation* section and refer to [Option 3](#).



## Installation Methods for DuPont Self-Adhered Flashing Products Installed BEFORE the DuPont™ Tyvek® WRB

### Non-Flanged Door Using DuPont™ VersaFlange™

This installation guide is intended for doors installed above grade and/or with wood floor construction. Use of VersaFlange™ requires a smooth-framed door for proper adhesion of the adhesive to the frame.

This method applies to the following products: DuPont™ Flashing Tape, DuPont™ StraightFlash™, DuPont™ VersaFlange™, DuPont™ FlexWrap™, and DuPont™ FlexWrap™ EZ

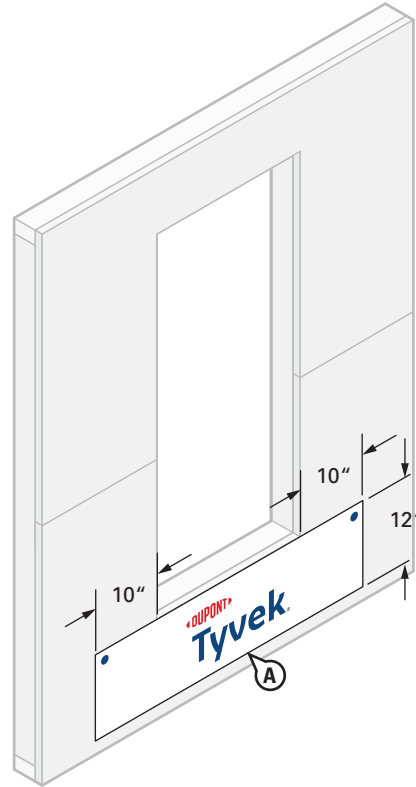

## STEP 1

### Prepare Tyvek® WRB Apron

- A. Cut an apron made of Tyvek® WRB for attachment under sill of rough opening. Apron should extend at least 10" BEYOND the sides of rough opening jambs (or to first stud in open stud construction) and at least 12" below sill of rough opening, or extend far enough below the sill rough opening to overlap the sill plate, base of wall flashing, or the Tyvek® WRB below. The top of the apron should be securely attached to the wall and the bottom of the apron should be left unsecured so it can overlap the Tyvek® WRB which will be installed after the door. Avoid placing DuPont™ Tyvek® Wrap Cap Fasteners where DuPont Self-Adhered Flashing Products will be installed.

## Installation Methods for DuPont Self-Adhered Flashing Products Installed BEFORE the DuPont™ Tyvek® WRB Non-Flanged Door Using DuPont™ VersaFlange™

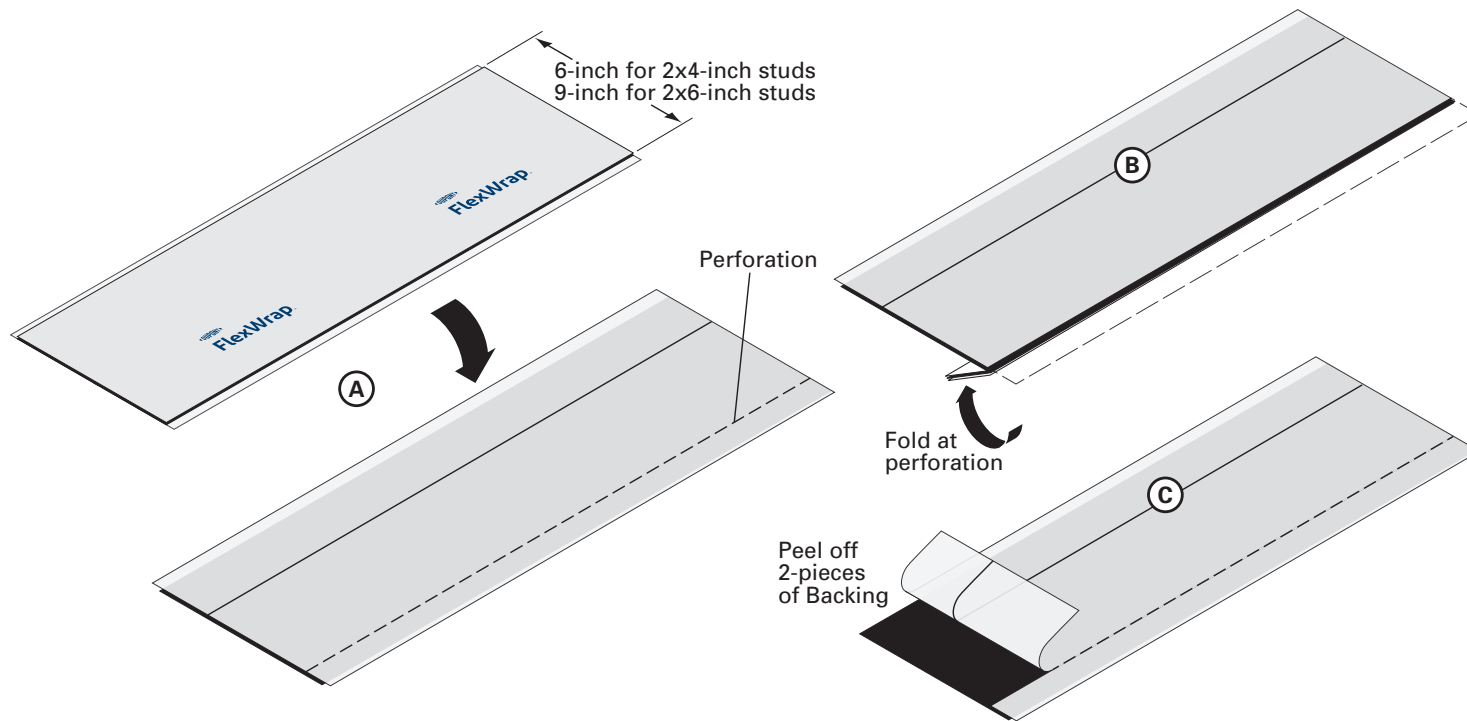

### STEP 2

#### Preparation of Sill Flashing

- A. Cut a piece of 9" wide DuPont™ FlexWrap™ at least 12" **LONGER** than the width of the sill (S).
- B. 9" FlexWrap™ has perforated release paper to help with the formation of a back dam. To ensure that the perforation tears cleanly, fold the perforation 180° and crease the flashing.
- C. Remove the two widest pieces of release paper leaving the narrowest release paper on the flashing. When the finished floor is applied, the release paper can be removed and the back dam can be completed.

## Installation Methods for DuPont Self-Adhered Flashing Products Installed BEFORE the DuPont™ Tyvek® WRB Non-Flanged Door Using DuPont™ VersaFlange™

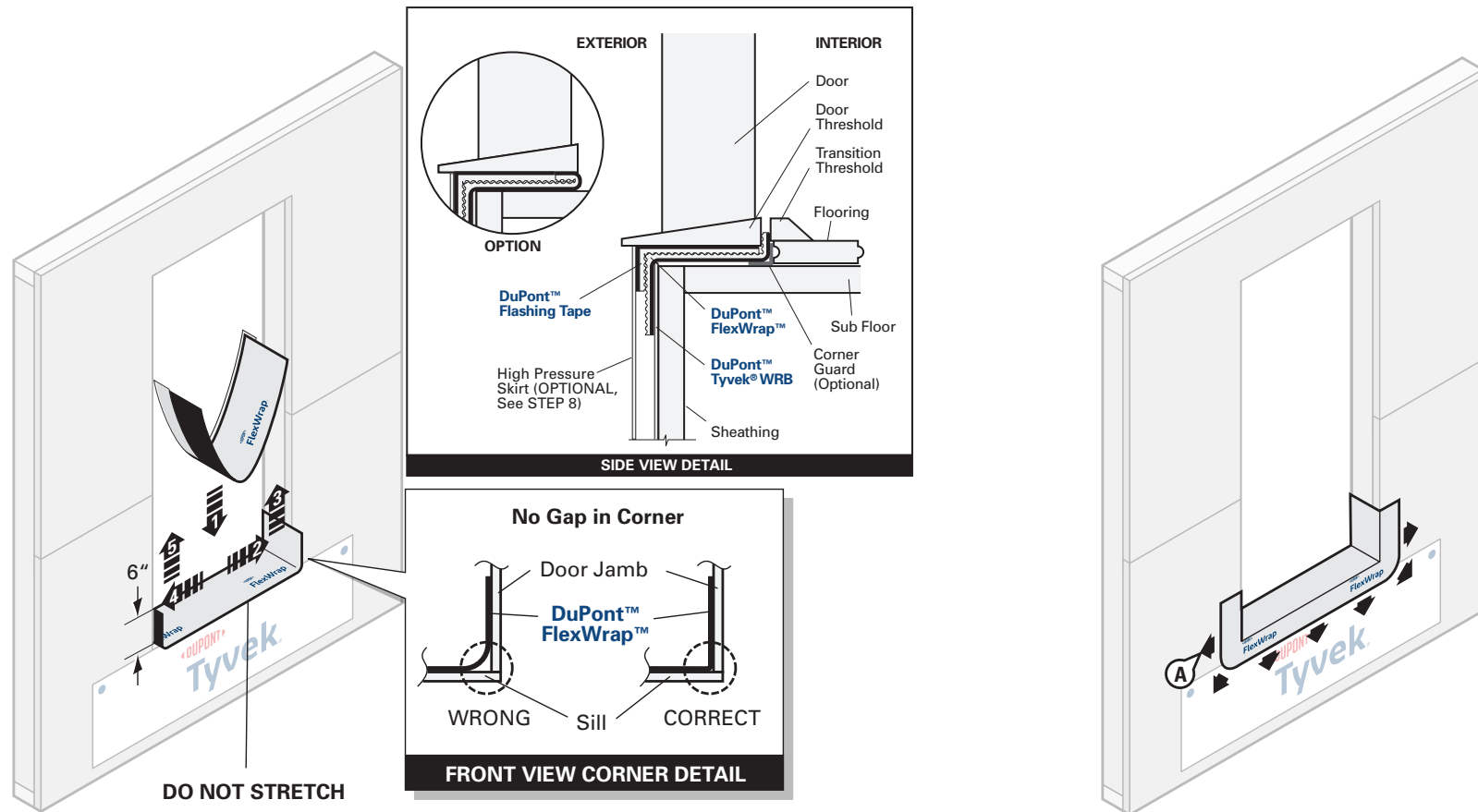

### STEP 3 (OPTIONAL BACK DAM)

Position the sill flashing as indicated so the section with the release paper still attached extends past the door threshold on the inside. Ensure that 2"– 3" of the **DuPont™ FlexWrap™** will be adhered to the face of the wall with a minimum of 6" up each jamb. Adhere into rough opening. When the narrow release paper is removed, the remaining section of **FlexWrap™** can be used to form a back dam.

**OPTIONAL: Create back dam by folding back narrow section of FlexWrap™.** Some flooring cannot accommodate a back dam. In that case fold the back dam on top of **FlexWrap™** in the sill. The door will be installed on top of the fold to create a back dam (see Side View Detail above).

### STEP 4

- A. Fan out the **FlexWrap™** at corners and adhere onto face of wall. Continue adhering onto face of wall along sill.

## Installation Methods for DuPont Self-Adhered Flashing Products Installed BEFORE the DuPont™ Tyvek® WRB

### Non-Flanged Door Using DuPont™ VersaFlange™

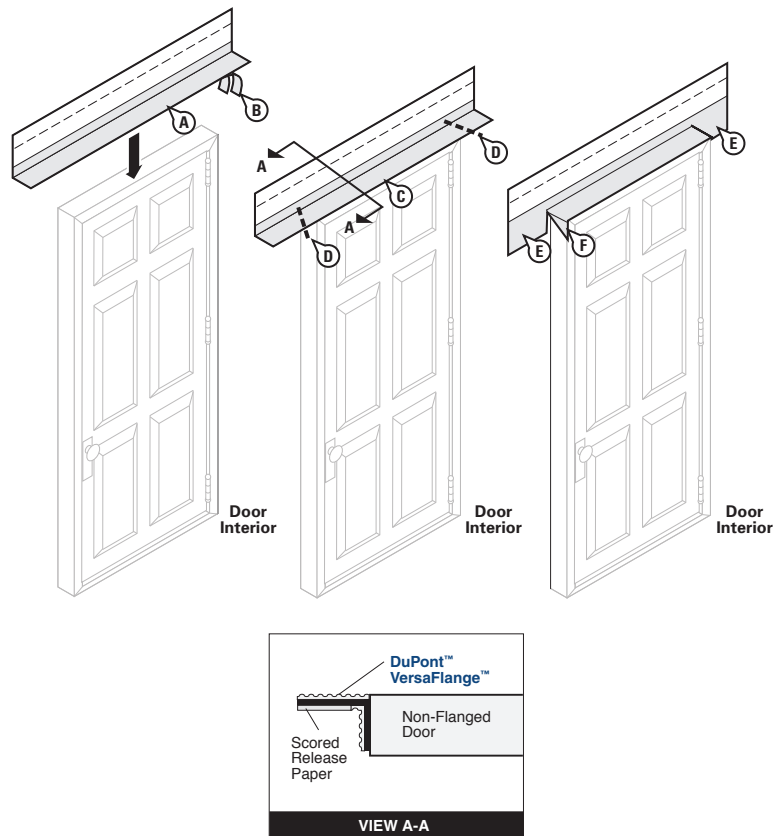

#### STEP 5

- Prepare head flashing by cutting a piece of **VersaFlange™** at least 12" **LONGER** than the head length.
- Remove the release paper from one side of the **VersaFlange™**.
- Center the **VersaFlange™** along the length of the door and position so that it contacts the door frame.
- Beginning at the junction of the jamb and head and away from the corners, cut the **VersaFlange™** at a 45° angle.
- Fold the newly created flashing flaps down parallel to the door frame.
- Fold the remaining head flashing flaps down and adhere to the jamb frame.

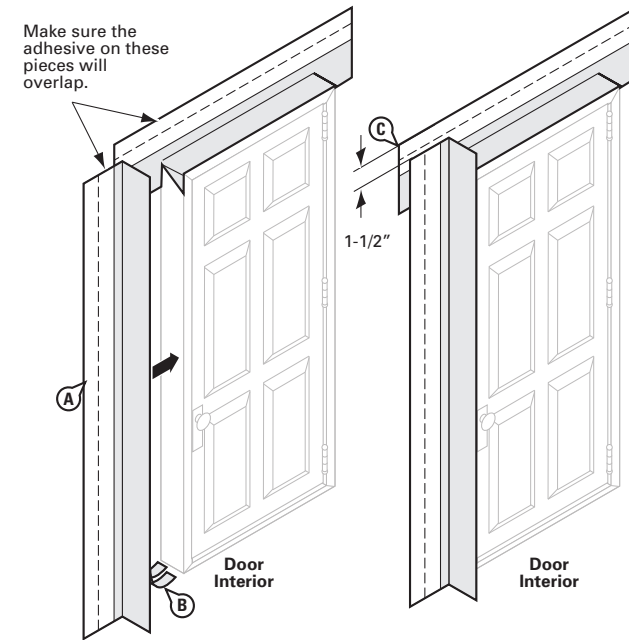

#### STEP 6

- Prepare jamb flashing by cutting a piece of **VersaFlange™** at least 6" **LONGER** than the jamb length.
- Remove the release paper from one side of the **VersaFlange™**.
- Position so that the **VersaFlange™** contacts the door frame up to the exterior face of the door. Ensure that the jamb flashing is positioned 1-1/2" below top of head flashing. **Jamb flashing adhesive must come in contact with head flashing adhesive and overlap by 1"**.
- Repeat on opposite jamb.

Installation Methods for DuPont Self-Adhered Flashing Products Installed BEFORE the DuPont™ Tyvek® WRB  
**Non-Flanged Door Using DuPont™ VersaFlange™**

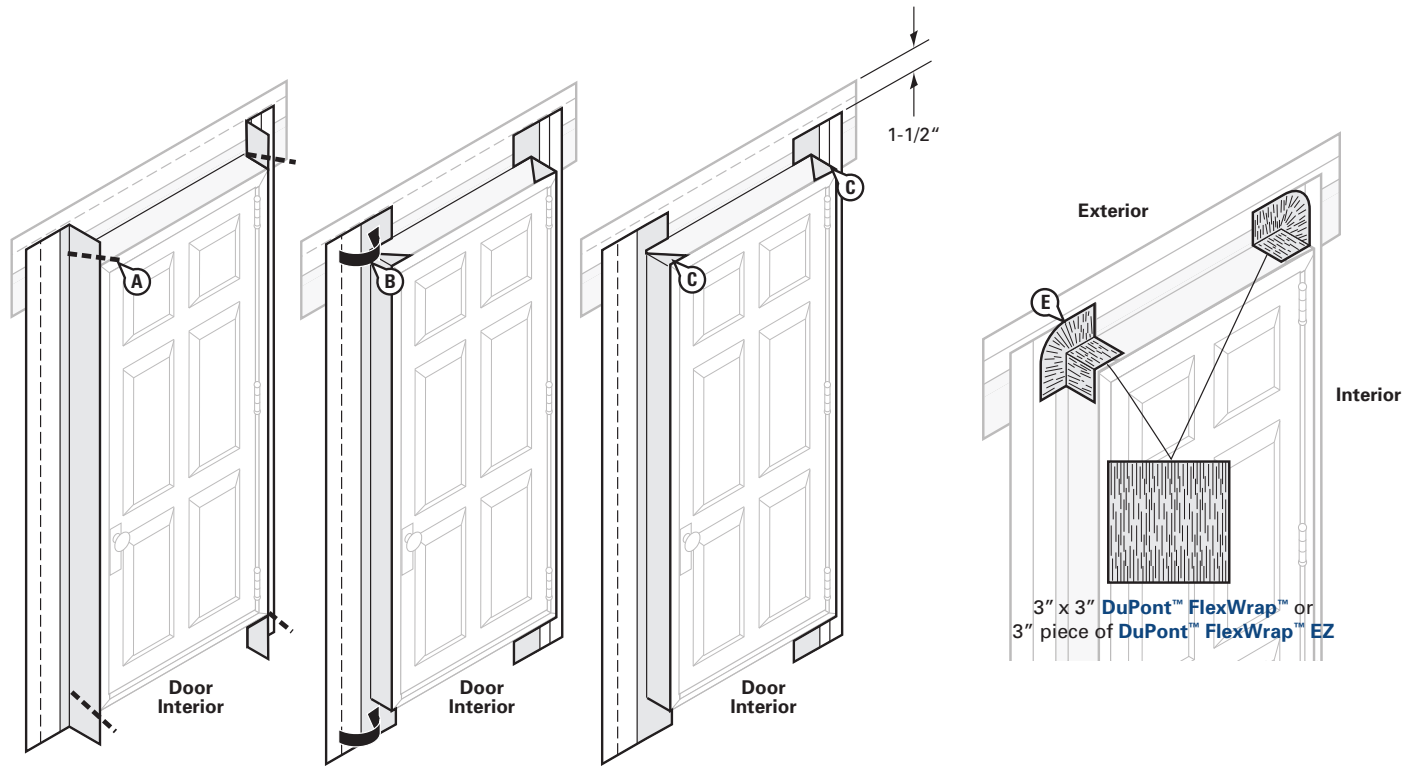

**STEP 7**

- A. Beginning at the junction of the jamb and the head, and away from the corner, cut the **VersaFlange™** at a 45° angle. Repeat the procedure at the junction of the sill and jambs.
- B. In order to overlap jamb adhesive to the head flashing adhesive, temporarily pull back release liner on the head flashing. Fold cut jamb flashing parallel to the door frame so that the jamb flashing lies flat onto the head flashing. Fold the head flashing release liner back down to protect any remaining exposed butyl along the head flashing prior to installation of the door.
- C. Fold remaining jamb flashing flaps down at all corners and adhere to the door frame.
- D. Repeat on opposite jamb.
- E. Cut two 3" x 3" pieces of **DuPont™ FlexWrap™** or two 3" pieces of **DuPont™ FlexWrap™ EZ** and add patches to corner of the door.

## Installation Methods for DuPont Self-Adhered Flashing Products Installed BEFORE the DuPont™ Tyvek® WRB Non-Flanged Door Using DuPont™ VersaFlange™

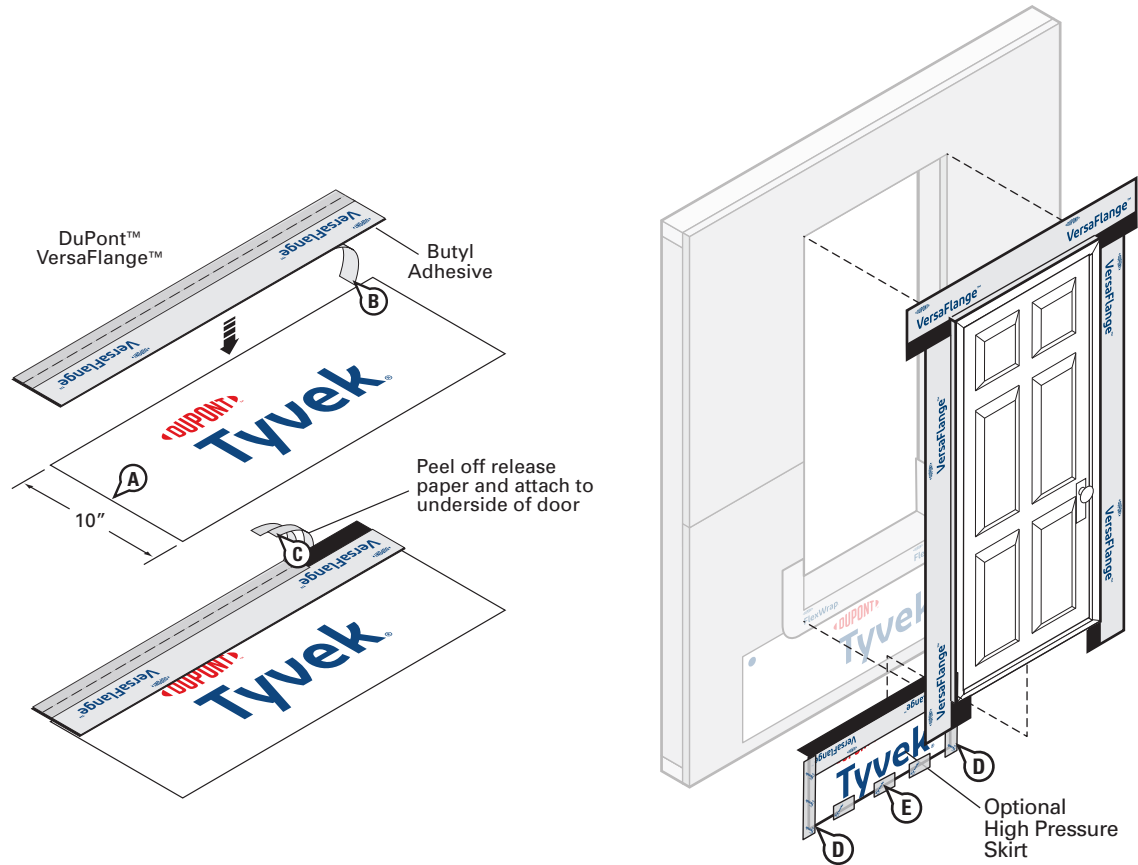

### STEP 8 (OPTIONAL - HIGH PRESSURE SKIRT)

For extreme/coastal exposures, installation of a high-pressure skirt is recommended to help prevent water intrusion at the sill or threshold.

- A. Create the high pressure skirt by cutting a piece of **Tyvek® WRB** 1" **WIDER** than the width of the door opening and approximately 10" in height.
- B. Cut a piece of **VersaFlange™** to the same width of skirt. Remove release paper from one side of the **VersaFlange™** and adhere to the **Tyvek® WRB**. The skirt may be made with **DuPont™ Flashing Tape**, **VersaFlange™**, or **DuPont™ StraightFlash™**.

- C. Remove the release paper from the other side of the **VersaFlange™** and adhere the butyl adhesive at the sill skirt to the underside of the door threshold behind the jamb flashing.
- D. After installation of door in Step 9, secure edges of the optional skirt with two 4" pieces of **DuPont™ Tyvek® Tape**, **DuPont™ Flashing Tape** or **StraightFlash™**.
- E. Tape the bottom of the optional skirt to allow for drainage and to minimize wind damage during construction.

## Installation Methods for DuPont Self-Adhered Flashing Products Installed BEFORE the DuPont™ Tyvek® WRB Non-Flanged Door Using DuPont™ VersaFlange™

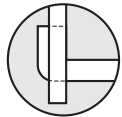
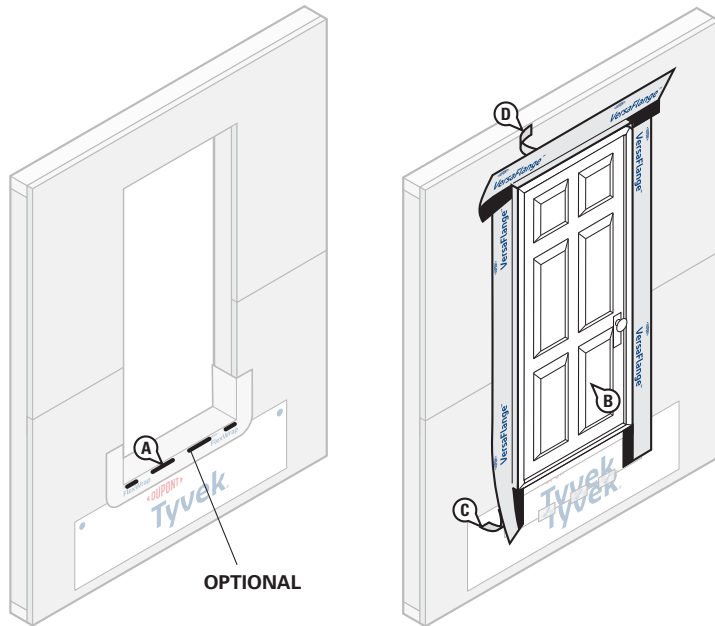

**INCORRECT**  
DuPont™ FlexWrap™  
reverse flashed

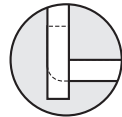

**INCORRECT**  
DuPont™ VersaFlange™  
flush with FlexWrap™

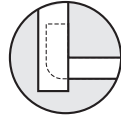

**CORRECT**  
VersaFlange™ overlaps  
FlexWrap™

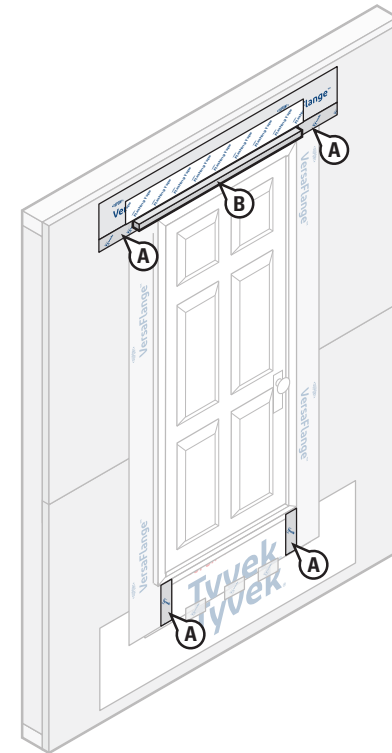

### STEP 9

- A. **OPTIONAL:** Apply Tower® Residential Sealant, or recommended sealant, along the sill as shown above. **To allow for drainage, do not apply continuous sealant bead along sill.** Ensure a minimum 2" wide drainage gap in the sealant bead within 4" from **each corner** of the jamb-sill interface. Continue applying sealant along the sill with additional 2" wide (min.) drainage gaps for every 6"– 12" (on center) of sill width.
- B. Install door according to manufacturer's installation instructions.
- C. Remove the remaining release paper from the **DuPont™ VersaFlange™** jamb flashing and press firmly to adhere the butyl adhesive to the exterior sheathing or framing members. **Do not reverse shingle. VersaFlange™** must overlap **DuPont™ FlexWrap™** and adhere to the substrate.
- D. Remove the release paper at the head and adhere the **VersaFlange™** to the exterior sheathing or framing members.

### STEP 10

- A. **OPTIONAL:** Cover exposed butyl with **DuPont™ Tyvek® Tape**, **DuPont™ Flashing Tape**, or **DuPont™ StraightFlash™**.
- B. **OPTIONAL:** If installing a drip cap as part of the door installation **BEFORE** the **Tyvek® WRB** is installed and sealed, see *Drip Cap Installation* section and refer to [Option 2](#).



**Installation Methods for DuPont Self-Adhered Flashing Products Installed BEFORE the DuPont™ Tyvek® WRB  
Non-Flanged Door Using DuPont™ VersaFlange™**

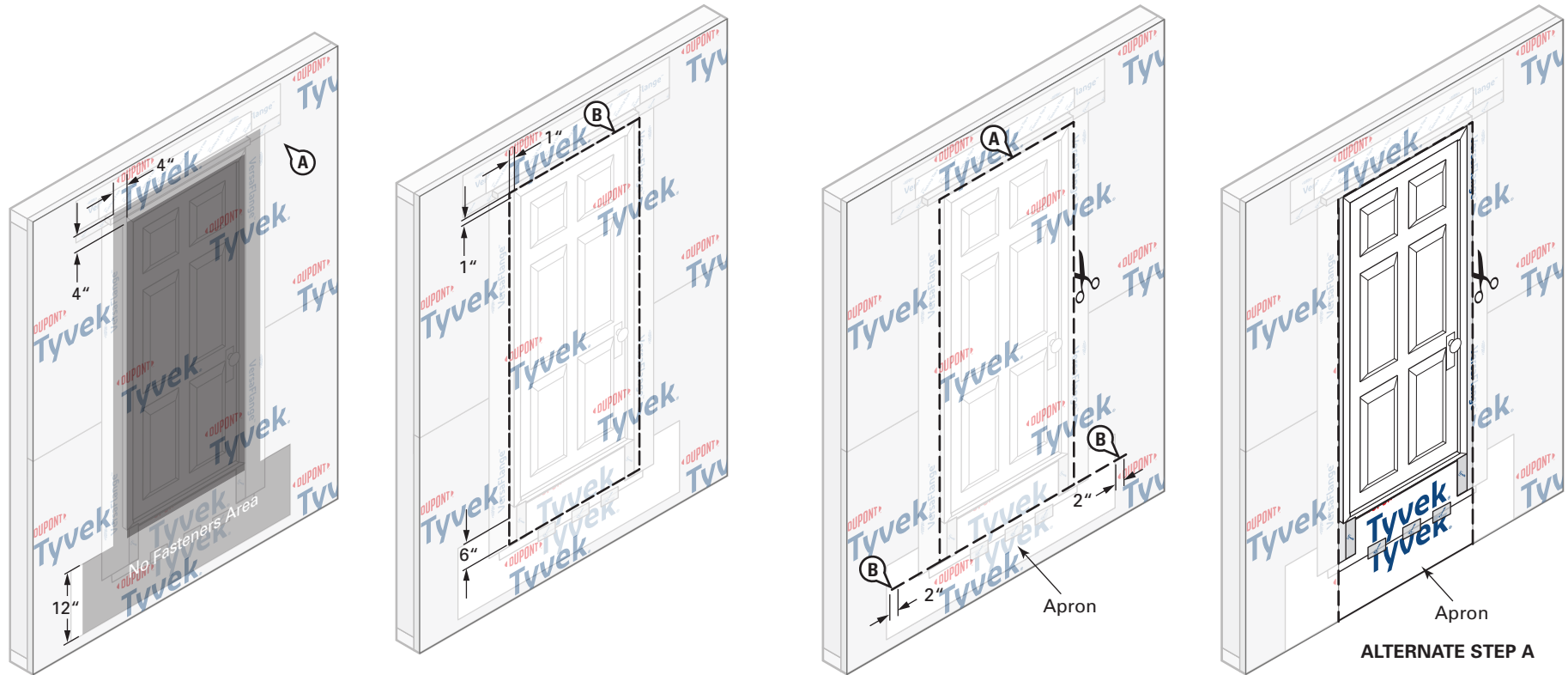

**STEP 11**

- A. Install the **Tyvek® WRB** as shown in the [DuPont™ Tyvek® WRB Installation Instructions](#) section of this document. Do not install fasteners within 4" of the door frame at jambs and head and within 12" of the door frame at sill or location of apron.
- B. Mark a perimeter on the **Tyvek® WRB** around the rough opening a minimum of 1" from the jambs and head of the door frame, and 6" below the sill of the door frame.

**STEP 12**

- A. Cut the **Tyvek® WRB** along perimeter marking to expose door. Do not cut through the **DuPont Self-Adhered Flashing Products** or **Tyvek® WRB** apron underneath.
- ALTERNATE STEP A:** If apron extends far enough below the sill rough opening to overlap the sill plate, base of wall flashing, or the **Tyvek® WRB** below, the **Tyvek® WRB** can be cut along jambs and head only to overlap apron.
- B. Create horizontal slits in the **Tyvek® WRB** at each lower corner of the perimeter cut that extend 1"– 2" **BEYOND** the **Tyvek® WRB** apron.

## Installation Methods for DuPont Self-Adhered Flashing Products Installed BEFORE the DuPont™ Tyvek® WRB Non-Flanged Door Using DuPont™ VersaFlange™

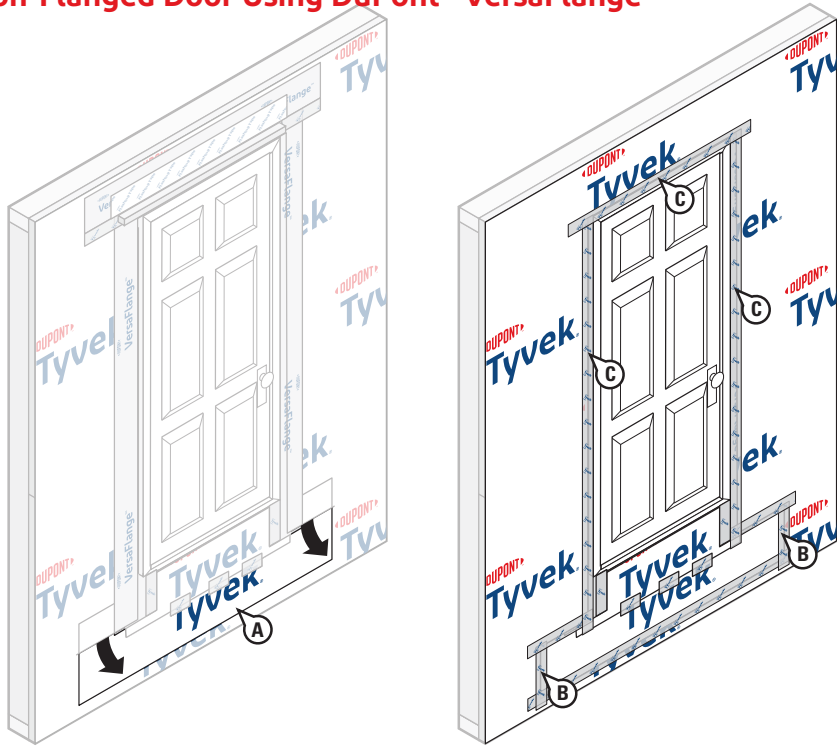

### STEP 13

- A. Bring the bottom portion of the **Tyvek® WRB** apron through the sill perimeter cut and horizontal slits so it laps over the top layer of **Tyvek® WRB**.
- B. Working from bottom to top, install **DuPont™ Tyvek® Tape** to secure horizontal and vertical seams of the **Tyvek® WRB** apron.
- C. Install **Tyvek® Tape** along jambs and head to seal **Tyvek® WRB** around door. For a more robust termination, **DuPont™ Flashing Tape** or **DuPont™ StraightFlash™** can be used. **OPTIONAL:** If installing a drip cap **AFTER** the **Tyvek® WRB** is installed and sealed, see *Drip Cap Installation* section and refer to [Option 3](#).

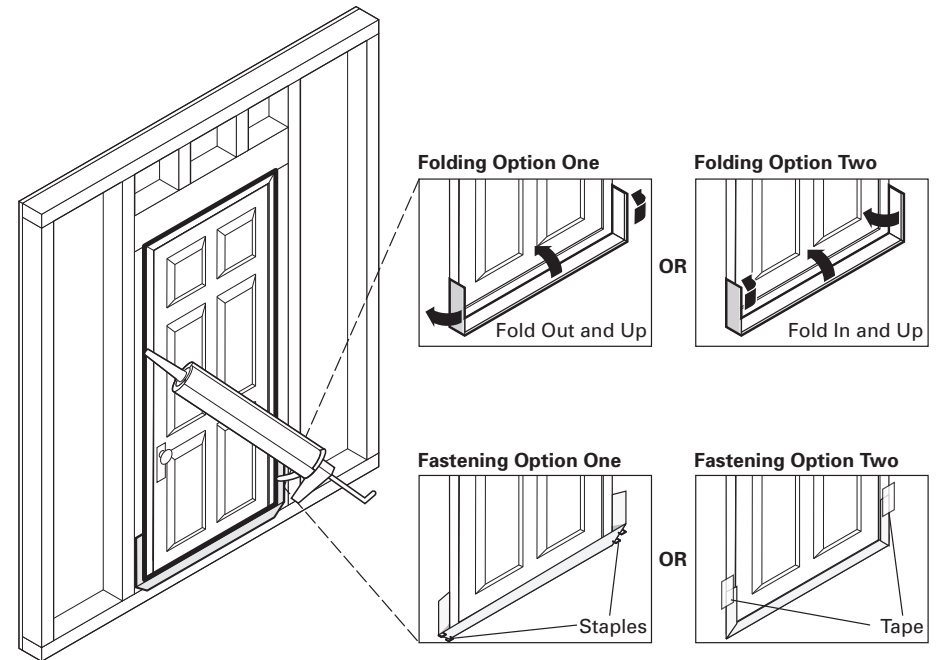

### STEP 14

#### Final Step

- D. When the interior flooring is ready to install, remove release paper and use Folding Option One or Two (shown above) to form back dam.
- E. Install Tower® Residential Sealant or recommended sealant (and backer rod as necessary) around the door opening at the interior. It is also acceptable to use **Great Stuff Pro™ Window & Door Polyurethane Foam Sealant**, or recommended foam. When using Tower® Residential Sealant, tool sealant bead flat to allow the natural curing process to create a concave shape. Be sure that the sealant penetrates the grooves of the **DuPont™ FlexWrap™** around the sill. When using **Great Stuff Pro™ Window & Door Polyurethane Foam Sealant** in perimeter openings less than 1/2", apply using the plastic extension tip for the **Great Stuff Pro™ Dispensing Gun** during installation.

## Installation Methods for DuPont Self-Adhered Flashing Products Installed BEFORE the DuPont™ Tyvek® WRB

### Field Applied Flanged Window

Ensure **DuPont™ VersaFlange™** logo side faces the exterior. This method may also be used for non-integral flanged windows. Use of **VersaFlange™** requires a smooth-framed window for proper adhesion to the frame.

This method applies to the following products: **DuPont™ Flashing Tape**, **DuPont™ StraightFlash™**, **DuPont™ VersaFlange™**, **DuPont™ FlexWrap™**, and **DuPont™ FlexWrap™ EZ**

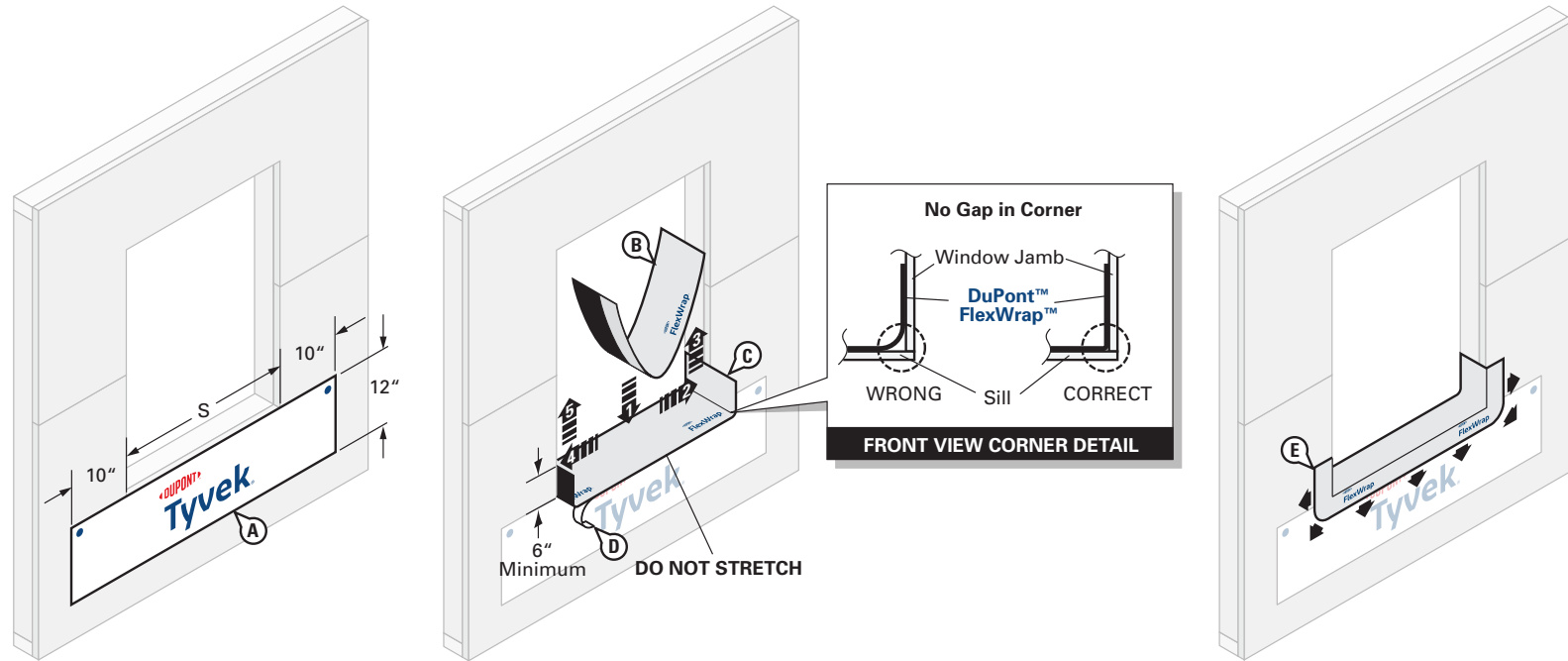

### STEP 1

- Cut an apron made of **Tyvek® WRB** for attachment under sill of rough opening. Apron should extend at least 10" **BEYOND** the sides of rough opening jambs (or to first stud in open stud construction) and at least 12" below sill of rough opening, or extend far enough below the sill rough opening to overlap the sill plate, base of wall flashing, or the **Tyvek® WRB** below. The top of the apron should be securely attached to the wall and the bottom of the apron should be left unsecured so it can overlap the **Tyvek® WRB** which will be installed after the window. Avoid placing **DuPont™ Tyvek® Wrap Cap Fasteners** where **DuPont Self-Adhered Flashing Products** will be installed.
- Cut **FlexWrap™** at least 12" **LONGER** than width of rough opening sill (S). Use roll widths sufficient to achieve a minimum of 1" adhesion **BEYOND** where the window frame will be located, ensuring 2"- 3" adhesion onto the face of the wall.
- Remove wide piece of release paper. Position on horizontal sill by aligning the inside edge of the narrow release paper with the face of the wall to ensure 2"- 3" of the **FlexWrap™** will be adhered to the face of the wall with a minimum of 6" up each jamb. Adhere into rough opening.
- Remove narrow release paper.
- Fan out the **FlexWrap™** at corners and adhere onto face of wall. Continue adhering onto face of wall along sill.

## Installation Methods for DuPont Self-Adhered Flashing Products Installed BEFORE the DuPont™ Tyvek® WRB Field Applied Flanged Window

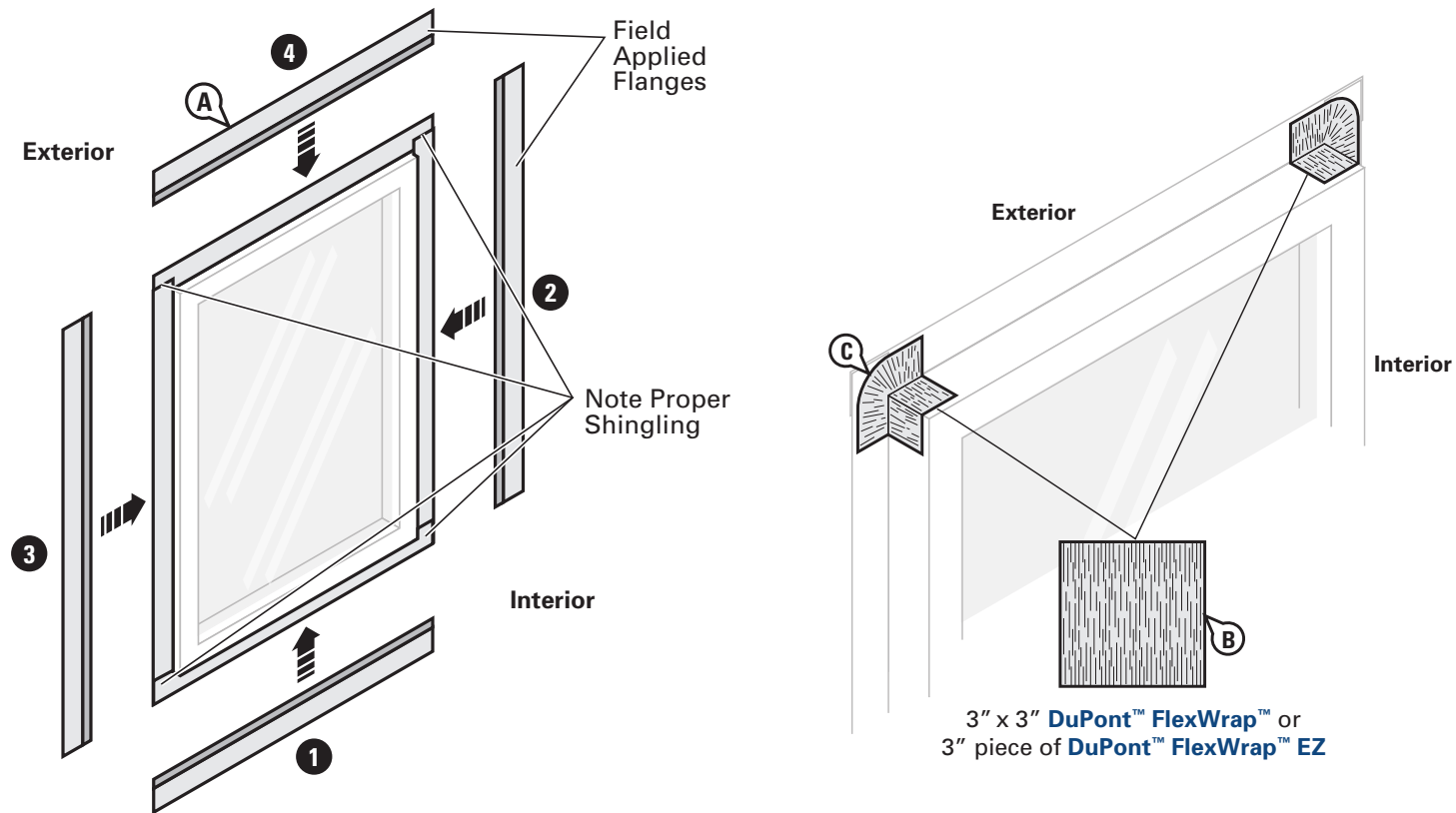

### STEP 2

A. Apply field applied flanges in the correct shingling fashion per manufacturer's installation instructions.

**DO NOT REVERSE SHINGLE.**

B. Cut four 3" x 3" pieces of DuPont™ FlexWrap™ or four 3" pieces of DuPont™ FlexWrap™ EZ.

C. Apply FlexWrap™ or FlexWrap™ EZ patches to back of flange corners before applying DuPont™ VersaFlange™.

## Installation Methods for DuPont Self-Adhered Flashing Products Installed BEFORE the DuPont™ Tyvek® WRB Field Applied Flanged Window

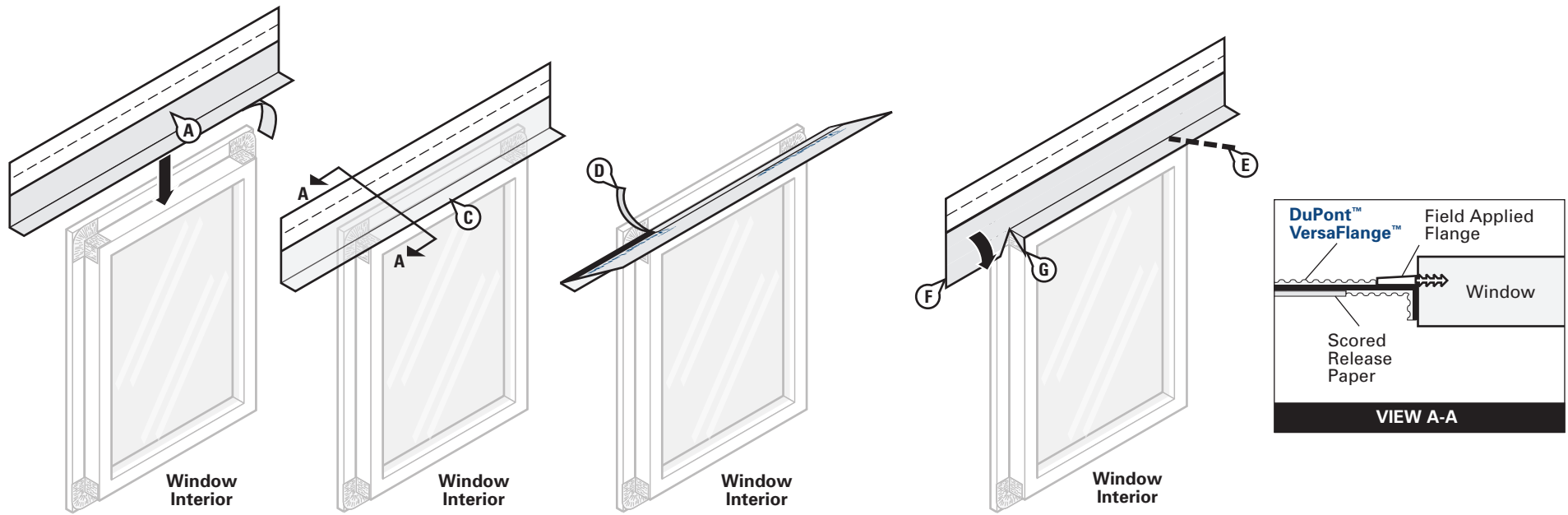

### STEP 3

- A. Prepare head flashing by cutting a piece of **DuPont™ VersaFlange™** at least 12" **LONGER** than the head length.
- B. Break the perforated release paper on one side of the head flashing by folding it back and forth upon itself.
- C. Center the **VersaFlange™** along the length of the window head and position so that it contacts the window frame and interior side of the flange. Remove the outer release paper and adhere the flashing to the window frame. Use the inner release paper to form a tight seal in the corner.
- D. Remove the inner release paper and adhere the flashing to the back of the flange.
- E. Beginning at the junction of the jamb and the head, and away from the corner, cut **VersaFlange™** at a 45° angle.
- F. Fold the newly created flaps down against the flange.
- G. Fold remaining head flashing flaps down onto the jamb.

## Installation Methods for DuPont Self-Adhered Flashing Products Installed BEFORE the DuPont™ Tyvek® WRB

### Field Applied Flanged Window

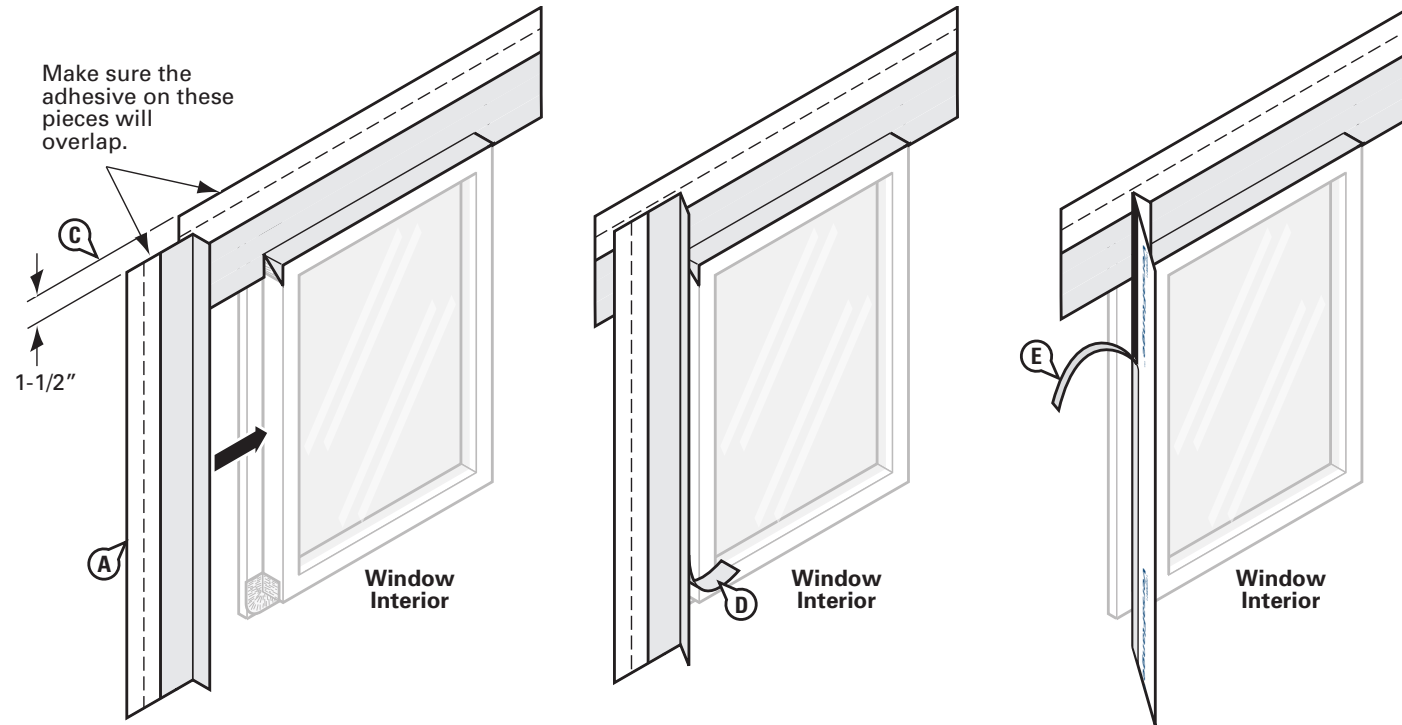

#### STEP 4

- A. Prepare jamb flashing by cutting a piece of **DuPont™ VersaFlange™** at least 6" **LONGER** than the jamb.
- B. Break the perforated release paper on one side of the jamb flashing by folding it back and forth upon itself.
- C. Position so that the **VersaFlange™** contacts the window frame and interior side of flange. Ensure that the jamb flashing is positioned 1-1/2" below the top edge of the head flashing. **Jamb flashing adhesive must come in contact with head flashing adhesive and overlap 1"**.
- D. Remove the outer release paper and adhere the flashing to the window frame. Use the inner release paper to form a tight seal in the corner.
- E. Remove the inner release paper and adhere the flashing to the back of the flange.
- F. Repeat on opposite jamb.

## Installation Methods for DuPont Self-Adhered Flashing Products Installed BEFORE the DuPont™ Tyvek® WRB Field Applied Flanged Window

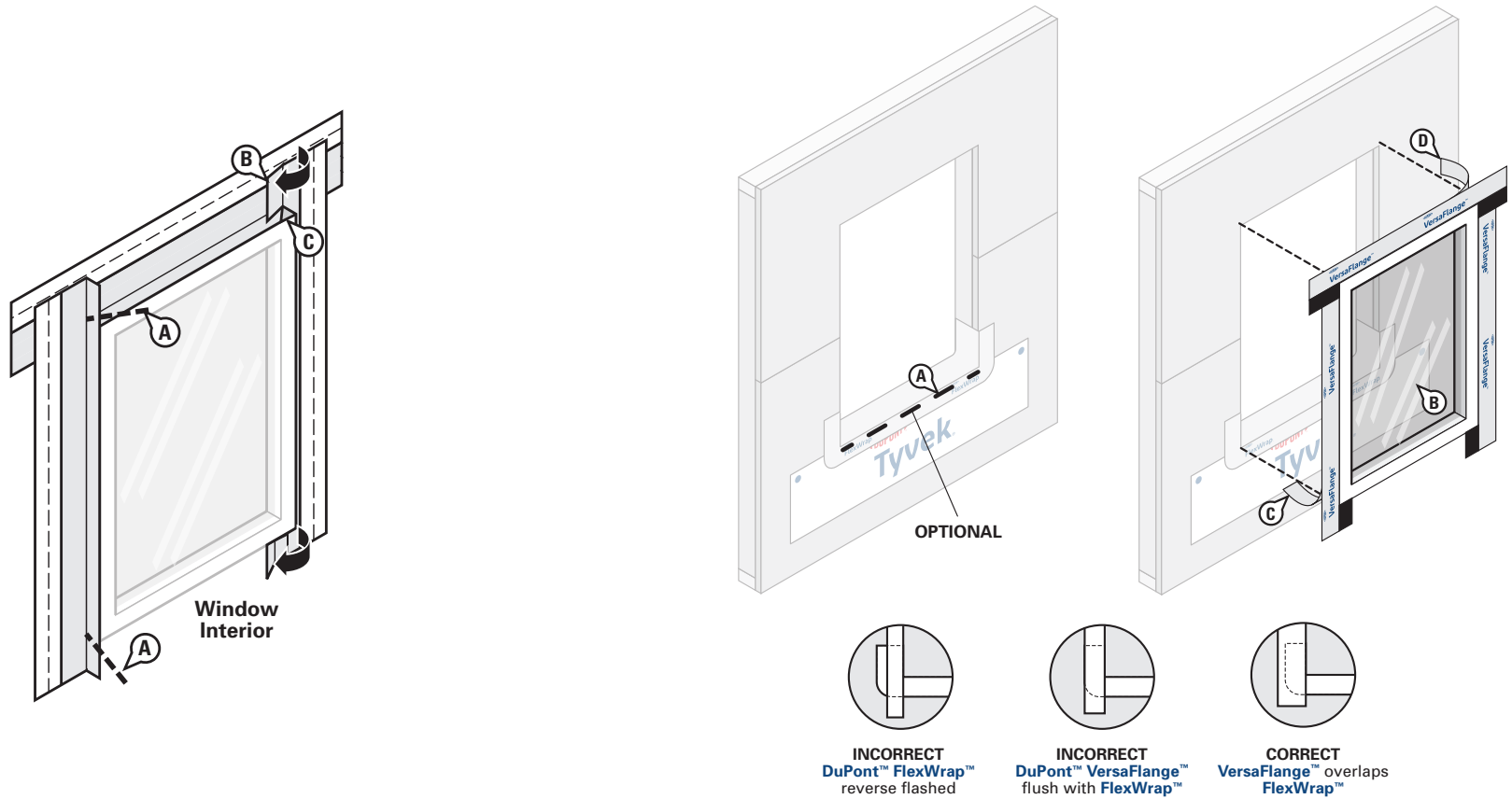

### STEP 5

- A. Beginning at the junction of the jamb and head, and away from the corner, cut the **DuPont™ VersaFlange™** at a 45° angle. Repeat the procedure at the junction of the sill and jamb.
- B. In order to overlap jamb adhesive to the head flashing adhesive, temporarily pull back release liner on the head flashing. Fold cut jamb flashing parallel to the window frame so that the jamb flashing lies flat onto the head flashing. Fold the head flashing release liner back down to protect any remaining exposed butyl along the head flashing prior to installation of the window.
- C. Fold remaining jamb flashing flaps down at all corners and adhere to the window frame.

### STEP 6

- A. **OPTIONAL:** Apply Tower® Residential Sealant, or recommended sealant, along the sill as shown above. **To allow for drainage, do not apply continuous sealant bead along sill.** Ensure a minimum 2" wide drainage gap in the sealant bead within 4" from **each corner** of the jamb-sill interface. Continue applying sealant along the sill with additional 2" wide (min.) drainage gaps for every 6"– 12" (on center) of sill width.
- B. Install window according to manufacturer's installation instructions.
- C. Remove the remaining release paper from the **VersaFlange™** jamb flashing and press firmly to adhere the butyl adhesive to the exterior sheathing or framing members. **Do not reverse shingle. VersaFlange™** must overlap **DuPont™ FlexWrap™** and adhere to the substrate.
- D. Remove the release paper at the head and adhere the **VersaFlange™** to the exterior sheathing or framing members.



## Installation Methods for DuPont Self-Adhered Flashing Products Installed BEFORE the DuPont™ Tyvek® WRB Field Applied Flanged Window

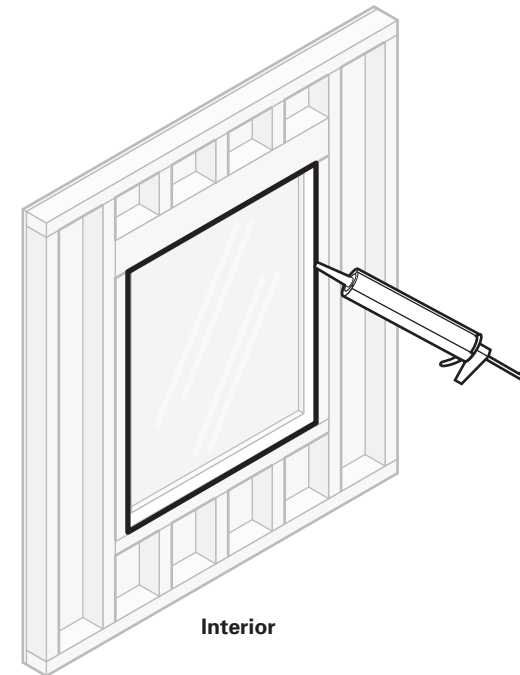
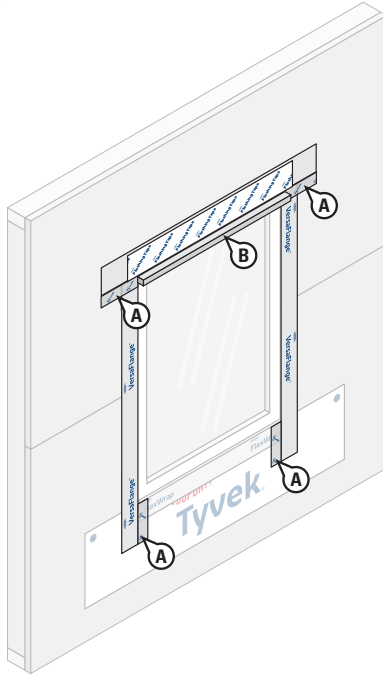

### STEP 7

- A. **OPTIONAL:** Cover exposed butyl with **DuPont™ Tyvek® Tape**, **DuPont™ Flashing Tape**, or **DuPont™ StraightFlash™**.
- B. **OPTIONAL:** If installing a drip cap as part of the window installation **BEFORE** the **Tyvek® WRB** is installed and sealed, see *Drip Cap Installation* section and refer to [Option 2](#).

### STEP 8

Install Tower® Residential Sealant or recommended sealant (and backer rod as necessary) around the window opening at the interior. It is also acceptable to use **Great Stuff Pro™ Window & Door Polyurethane Foam Sealant**, or recommended foam. When using Tower® Residential Sealant, tool sealant bead flat to allow the natural curing process to create a concave shape. Be sure that the sealant penetrates the grooves of the **DuPont™ FlexWrap™** around the sill. When using **Great Stuff Pro™ Window & Door Polyurethane Foam Sealant** in perimeter openings less than 1/2", apply using the plastic extension tip for the **Great Stuff Pro™ Dispensing Gun** during installation.

## Installation Methods for DuPont Self-Adhered Flashing Products Installed BEFORE the DuPont™ Tyvek® WRB Field Applied Flanged Window

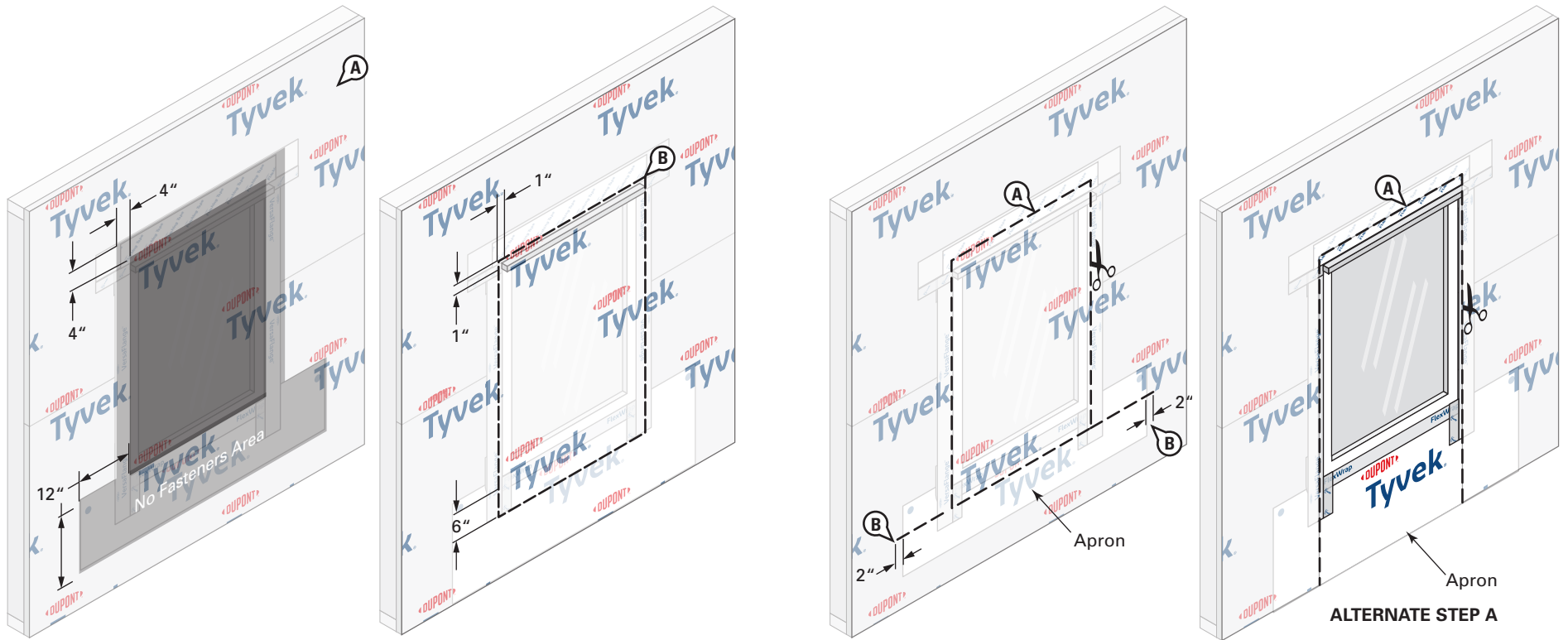

### STEP 9

- Install the **Tyvek® WRB** as shown in the [DuPont™ Tyvek® WRB Installation Instructions](#) section of this document. Do not install fasteners within 4" of the window frame at jambs and head and within 12" of the window frame at sill or location of apron.
- Mark a perimeter on the **Tyvek® WRB** around the rough opening a minimum of 1" from the jambs and head of the window frame, and 6" below the sill of the window frame.

### STEP 10

- Cut the **Tyvek® WRB** along perimeter marking to expose window. Do not cut through the **DuPont Self-Adhered Flashing Products** or **Tyvek® WRB** apron underneath.

**ALTERNATE STEP A:** If apron extends far enough below the sill rough opening to overlap the sill plate, base of wall flashing, or the **Tyvek® WRB** below, the **Tyvek® WRB** can be cut along jambs and head only to overlap apron.

- Create horizontal slits in the **Tyvek® WRB** at each lower corner of the perimeter cut that extend 1"– 2" **BEYOND** the **Tyvek® WRB** apron.

## Installation Methods for DuPont Self-Adhered Flashing Products Installed BEFORE the DuPont™ Tyvek® WRB Field Applied Flanged Window

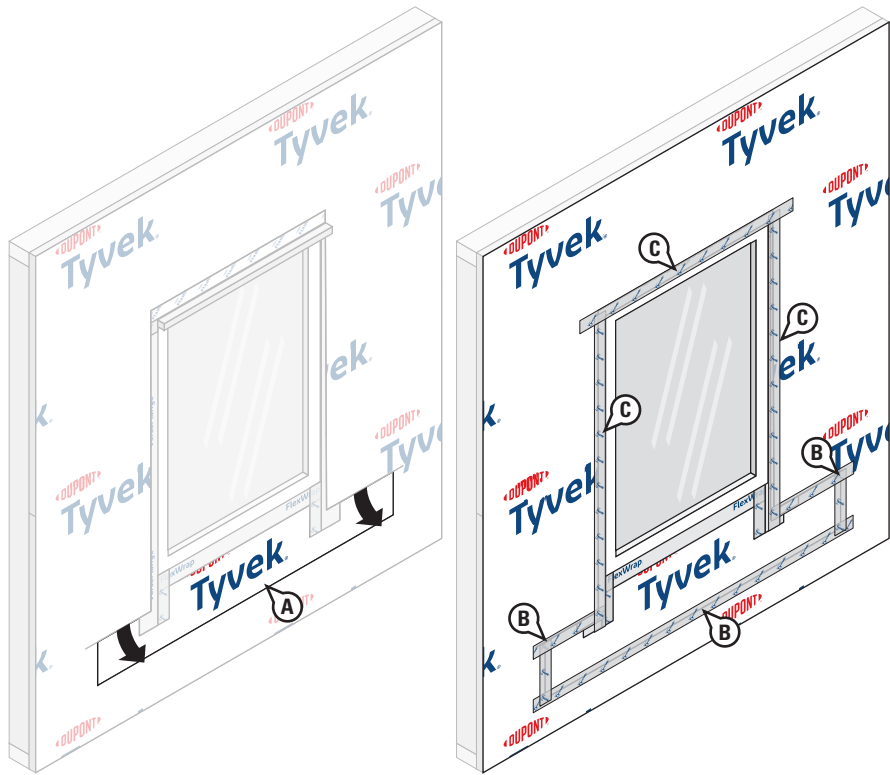

### STEP 11

#### Final Step

- A. Bring the bottom portion of the **Tyvek® WRB** apron through the sill perimeter cut and horizontal slits so it laps over the top layer of **Tyvek® WRB**.
- B. Working from bottom to top, install **DuPont™ Tyvek® Tape** to secure horizontal and vertical seams of the **Tyvek® WRB** apron.
- C. Install **Tyvek® Tape** along jambs and head to seal **Tyvek® WRB** around window. For a more robust termination, **DuPont™ Flashing Tape** or **DuPont™ StraightFlash™** can be used.

**OPTIONAL:** If installing a drip cap **AFTER** the **Tyvek® WRB** is installed and sealed, see *Drip Cap Installation* section and refer to [Option 3](#).

## Installation Methods for DuPont Self-Adhered Flashing Products Installed BEFORE the DuPont™ Tyvek® WRB

### Field Applied Flanged Door

This method may also be used for non-integral flanged doors. Doors that have a nailing fin or flange that is not continuous around the perimeter of the door or the fin/flange is not a direct extrusion of the frame (e.g. field-applied flanges) is considered a non-integral flanged unit. Use of DuPont™ VersaFlange™ requires a smooth-framed door for proper adhesion to the frame.

This method applies to the following products: DuPont™ Flashing Tape, DuPont™ StraightFlash™, DuPont™ VersaFlange™, DuPont™ FlexWrap™, and DuPont™ FlexWrap™ EZ

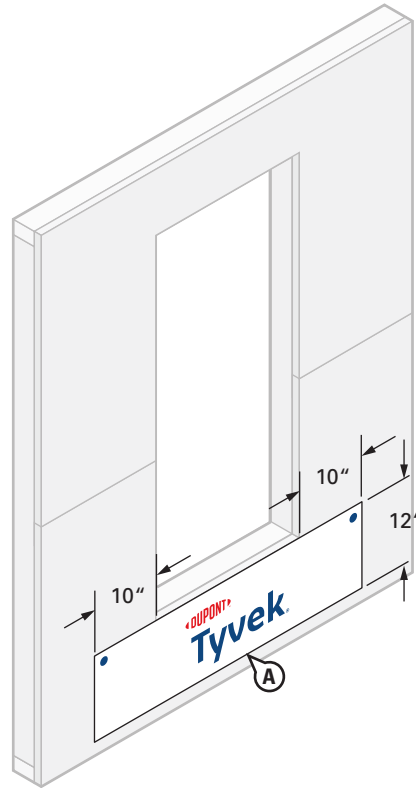

### STEP 1

#### Prepare Tyvek® WRB Apron

Cut an apron made of Tyvek® WRB for attachment under sill of rough opening. Apron should extend at least 10" **BEYOND** the sides of rough opening jambs (or to first stud in open stud construction) and at least 12" below sill of rough opening, or extend far enough below the sill rough opening to overlap the sill plate, base of wall flashing, or the Tyvek® WRB below. The top of the apron should be securely attached to the wall and the bottom of the apron should be left unsecured so it can overlap the Tyvek® WRB which will be installed after the door. Avoid placing DuPont™ Tyvek® Wrap Cap Fasteners or recommended fasteners where DuPont Self-Adhered Flashing Products will be installed.

## Installation Methods for DuPont Self-Adhered Flashing Products Installed BEFORE the DuPont™ Tyvek® WRB

### Field Applied Flanged Door

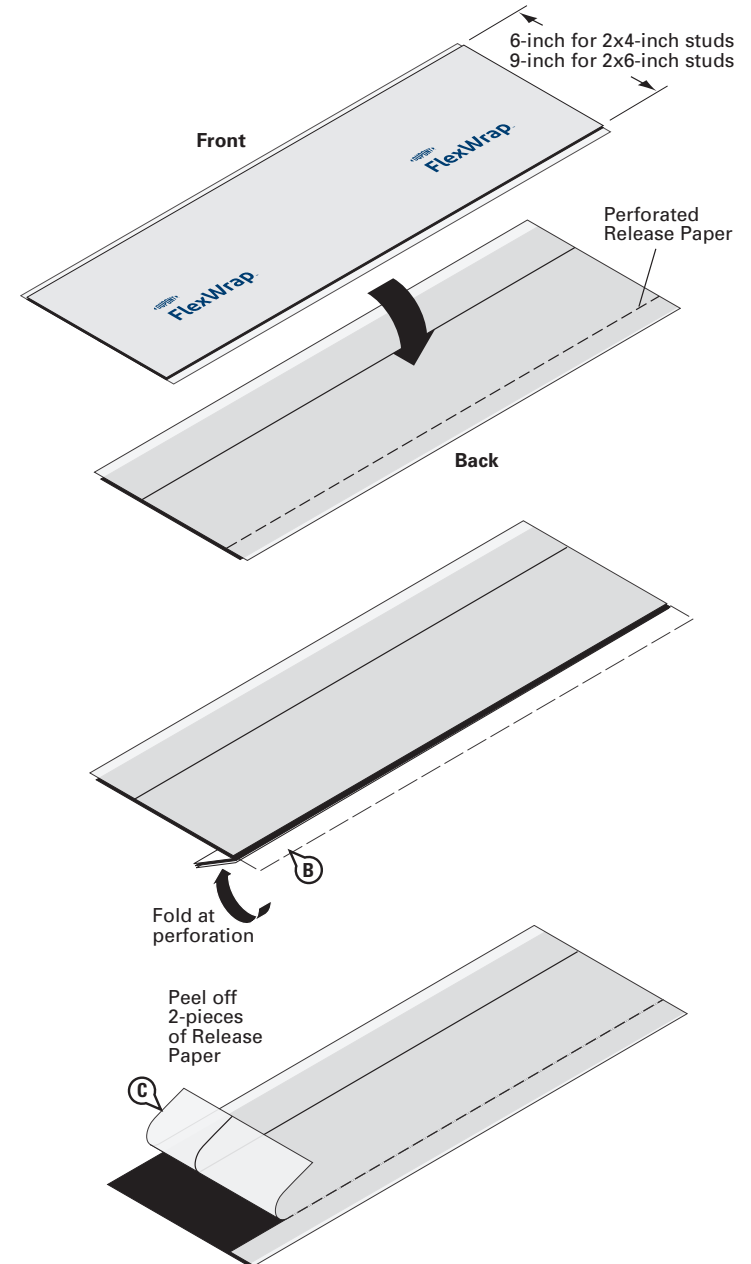
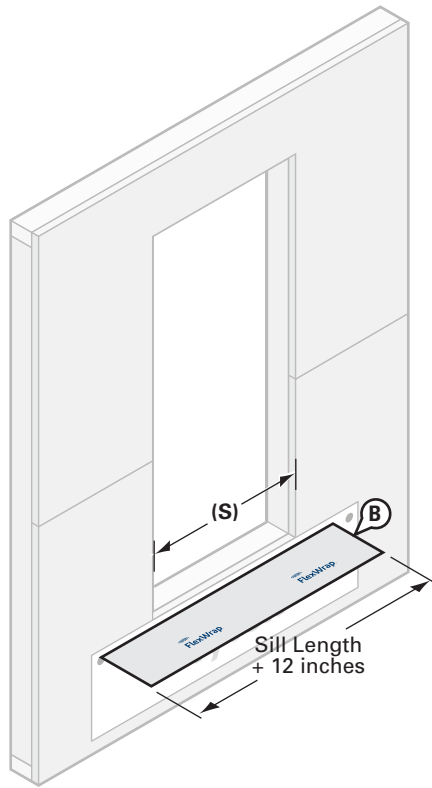

## STEP 2

### Preparation of Sill Flashing

- A. Cut a piece of 9" wide **DuPont™ FlexWrap™** at least 12" **LONGER** than the width of the sill (S).
- B. 9" **FlexWrap™** has perforated release paper to help with the formation of a back dam. To ensure that the perforation tears cleanly, fold the perforation 180° and crease the flashing.
- C. Remove the two widest pieces of release paper leaving the narrowest release paper on the flashing. When the finished floor is applied, the release paper can be removed and the back dam can be completed.

## Installation Methods for DuPont Self-Adhered Flashing Products Installed BEFORE the DuPont™ Tyvek® WRB Field Applied Flanged Door

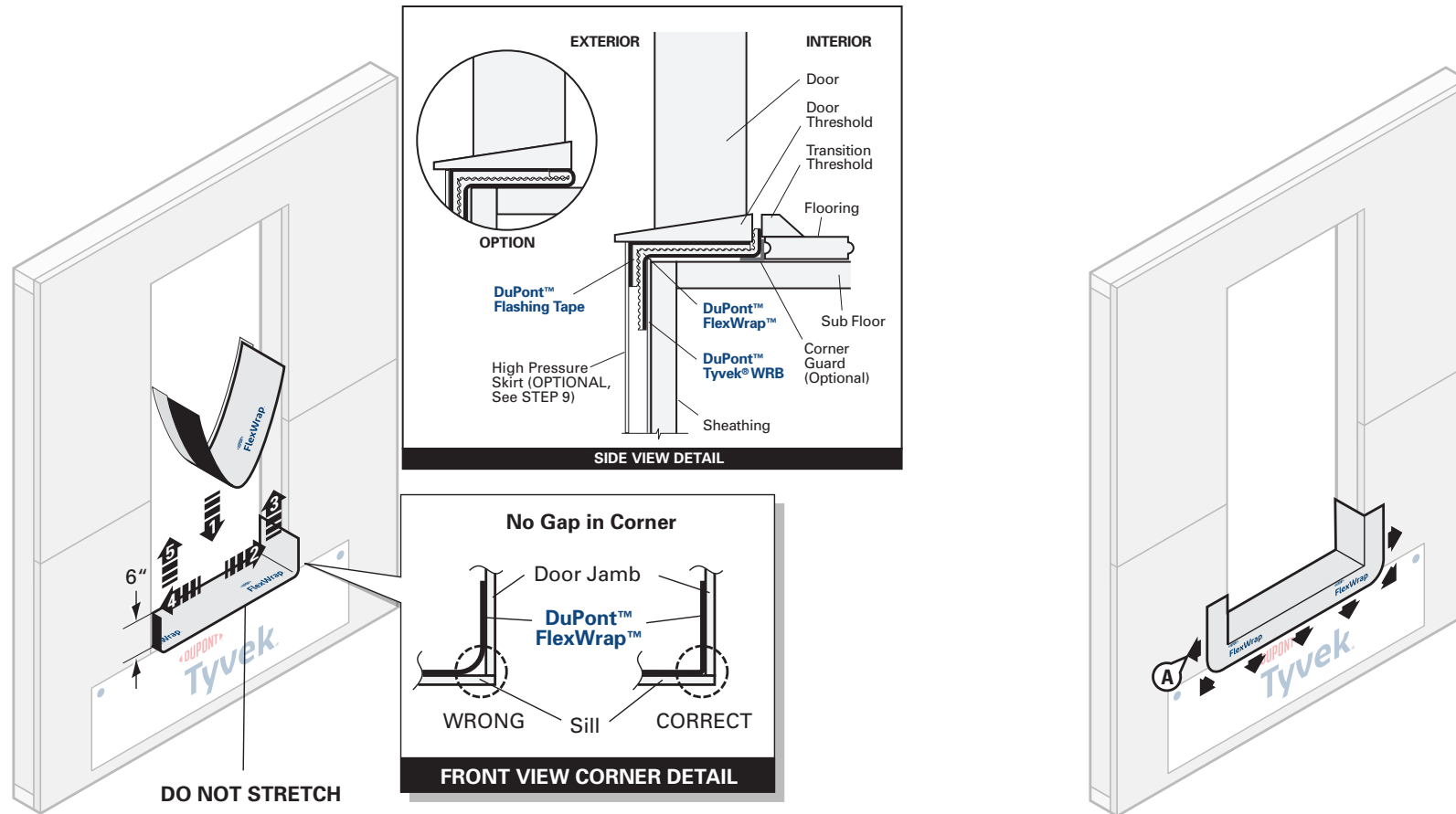

### STEP 3

Position the sill flashing as indicated so the section with the release paper still attached extends past the door threshold on the inside. Ensure that 2"– 3" of the **DuPont™ FlexWrap™** will be adhered to the face of the wall with a minimum of 6" up each jamb. Adhere into rough opening. When the narrow release paper is removed, the remaining section of **FlexWrap™** can be used to form a back dam.

**OPTIONAL: Create back dam by folding back narrow section of FlexWrap™.** Some flooring cannot accommodate a back dam. In that case fold the back dam on top of **FlexWrap™** in the sill. The door will be installed on top of the fold to create a back dam (see Side View Detail above).

### STEP 4

A. Fan out the **FlexWrap™** at corners and adhere onto face of wall. Continue adhering onto face of wall along sill.

## Installation Methods for DuPont Self-Adhered Flashing Products Installed BEFORE the DuPont™ Tyvek® WRB Field Applied Flanged Door

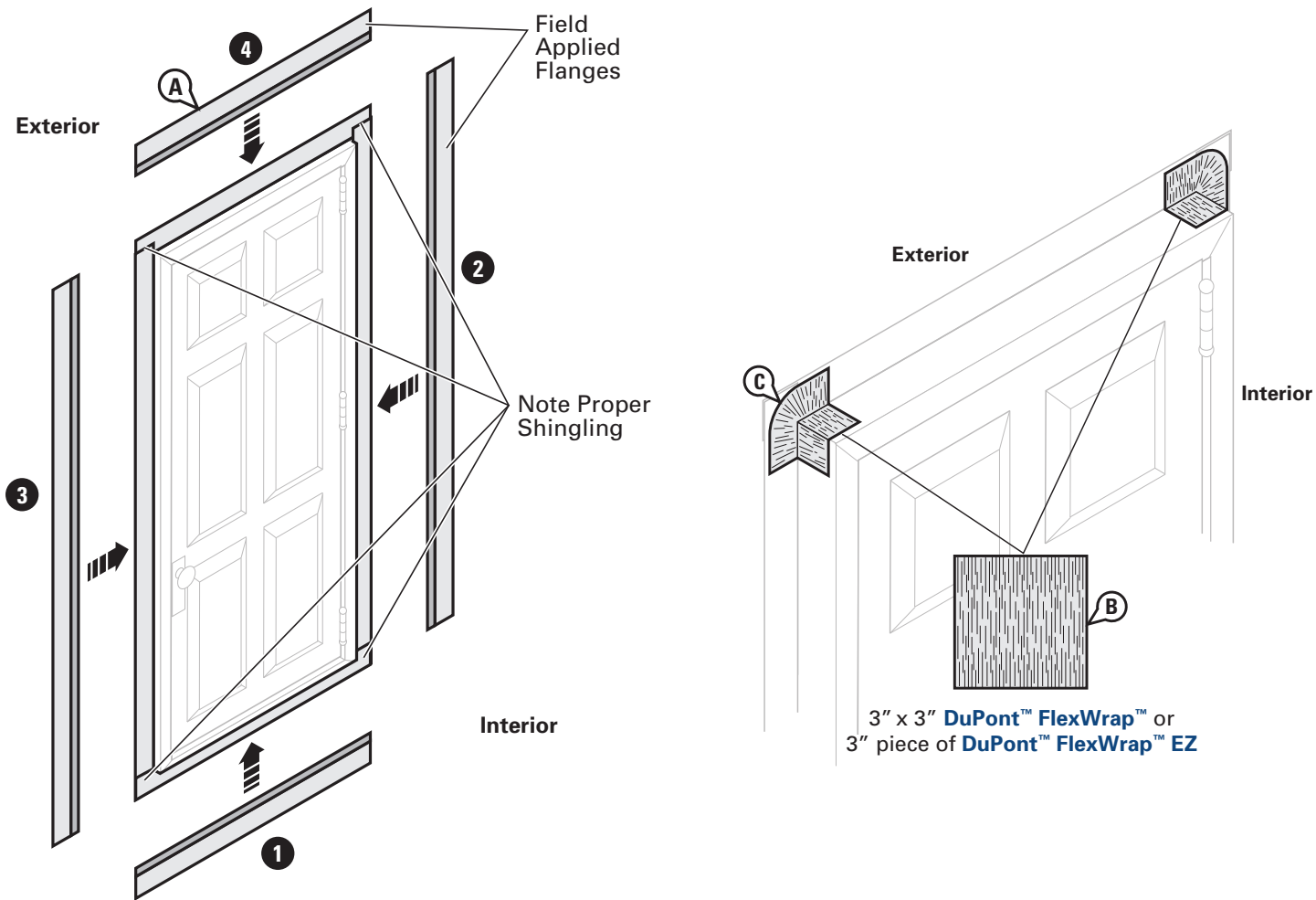

### STEP 5

A. Apply field applied flanges in the correct shingling fashion per manufacturer's installation instructions.

**DO NOT REVERSE SHINGLE.**

B. Cut four 3" x 3" pieces of **DuPont™ FlexWrap™** or four 3" pieces of **DuPont™ FlexWrap™ EZ**.

C. Apply **FlexWrap™** or **FlexWrap™ EZ** patches to back of flange corners before applying **DuPont™ VersaFlange™**.



## Installation Methods for DuPont Self-Adhered Flashing Products Installed BEFORE the DuPont™ Tyvek® WRB

### Field Applied Flanged Door

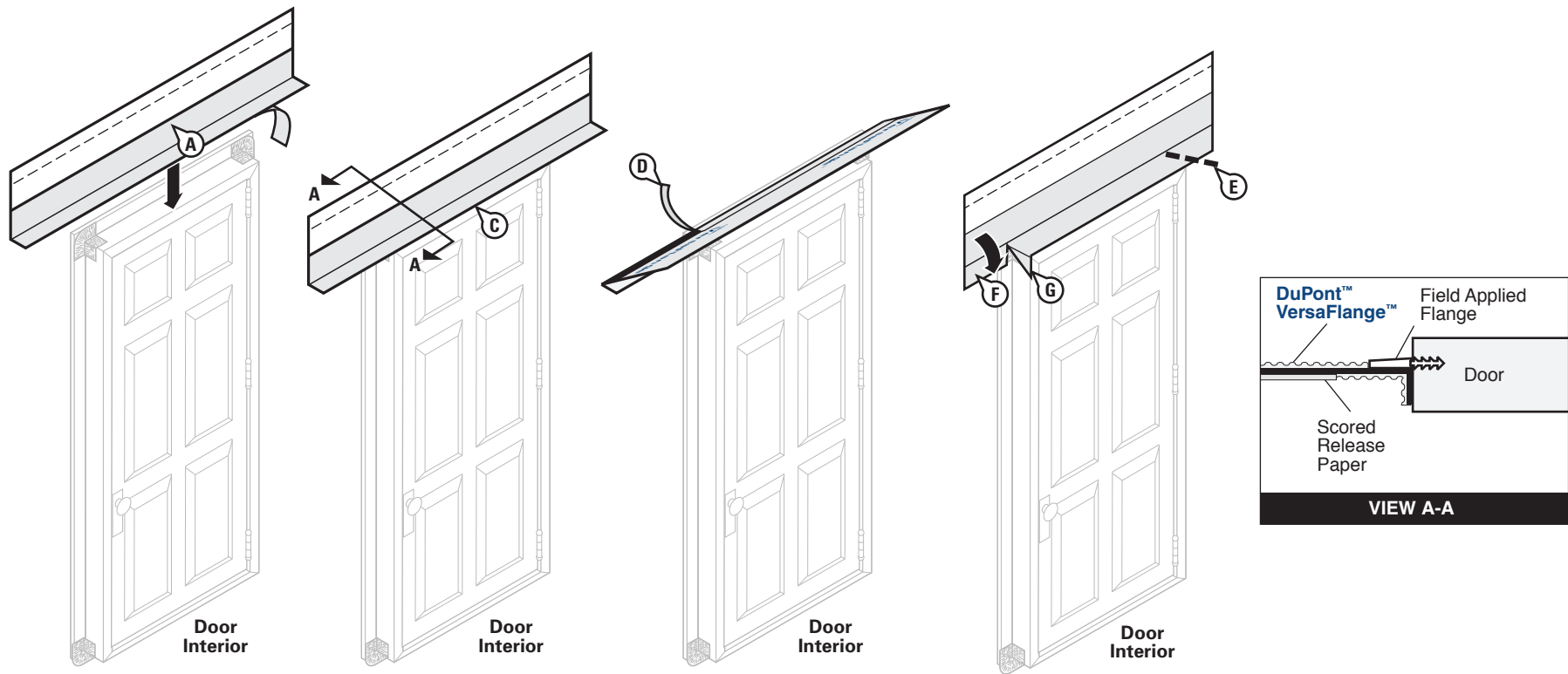

## STEP 6

- A. Prepare head flashing by cutting a piece of **DuPont™ VersaFlange™** at least 12" **LONGER** than the head length.
- B. Break the scored release paper on one edge of the head flashing by folding it back and forth upon itself.
- C. Center the **VersaFlange™** along the length of the door head and position so that it contacts the door frame and interior side of the flange. Remove the outer release paper and adhere the flashing to the door frame. Use the inner release paper to form a tight seal in the corner.
- D. Remove the inner release paper and adhere the flashing to the back of the flange.
- E. Beginning at the junction of the jamb and the head, and away from the corner, cut the **VersaFlange™** at a 45° angle.
- F. Fold the newly created flashing flap down flat against the flange.
- G. Fold remaining head flashing flaps down onto the jamb frame.

## Installation Methods for DuPont Self-Adhered Flashing Products Installed BEFORE the DuPont™ Tyvek® WRB

### Field Applied Flanged Door

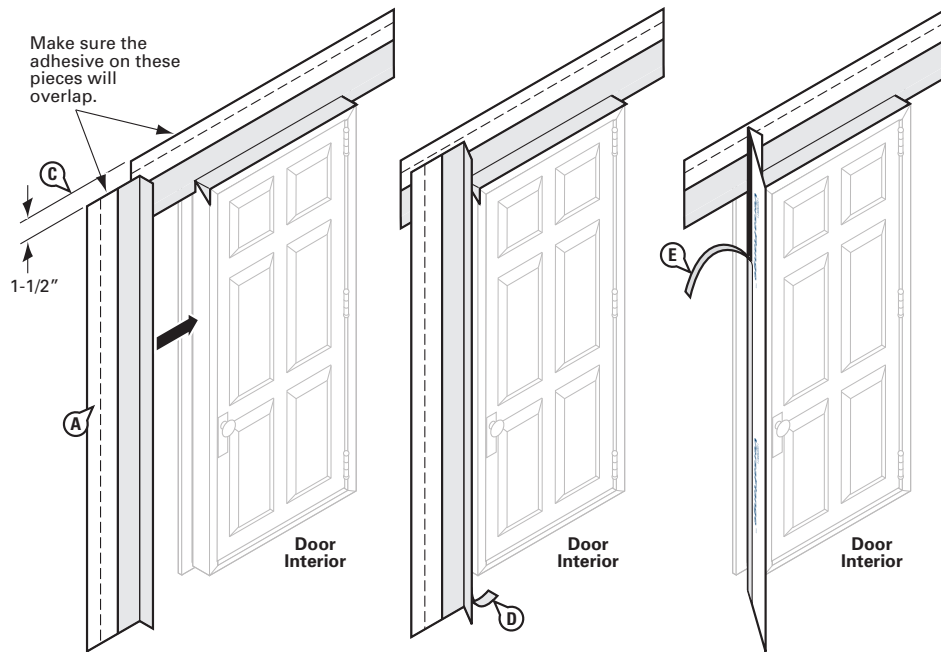

#### STEP 7

- Prepare jamb flashing by cutting a piece of **DuPont™ VersaFlange™** at least 6" **LONGER** than the jamb.
- Break the perforated release paper on one side of the jamb flashing by folding it back and forth upon itself.
- Position so that **VersaFlange™** contacts the door frame and interior side of the flange. Ensure that the jamb flashing is positioned 1-1/2" below the top edge of the head flashing. **Jamb flashing adhesive must come in contact with head flashing adhesive by 1"**.
- Remove the outer release paper and adhere the flashing to the door frame. Use the inner release paper to form a tight seal in the corner.
- Remove the inner release paper and adhere the flashing to the back of the flange.
- Repeat on opposite jamb.

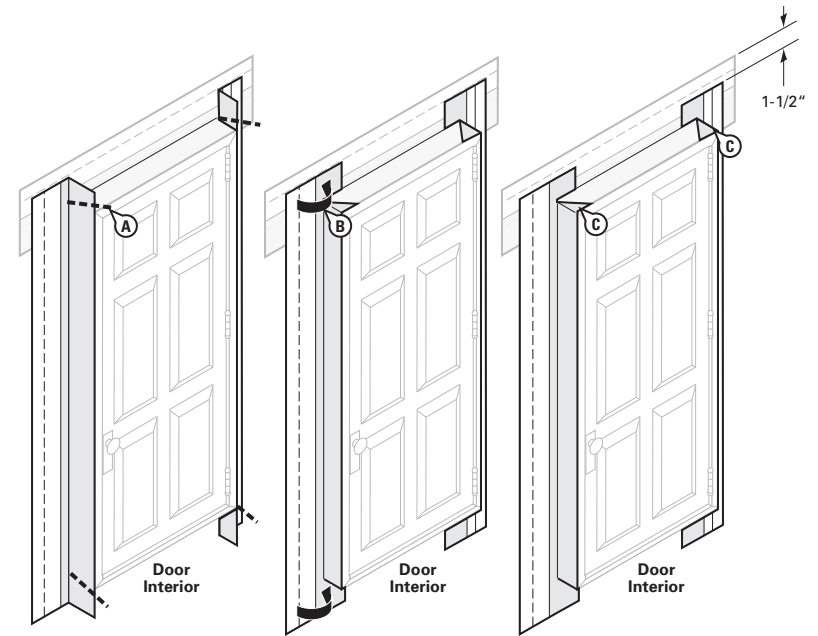

#### STEP 8

- Beginning at the junction of the jamb and head, and away from the corner, cut the **VersaFlange™** at a 45° angle. Repeat the procedure at the junction of the sill and jamb.
- In order to overlap jamb adhesive to the head flashing adhesive, temporarily pull back release liner on the head flashing. Fold cut jamb flashing parallel to the door frame so that the jamb flashing lies flat onto the head flashing. Fold the head flashing release liner back down to protect any remaining exposed butyl along the head flashing prior to installation of the door.
- Fold remaining jamb flashing flaps down at all corners and adhere to the door frame.

## Installation Methods for DuPont Self-Adhered Flashing Products Installed BEFORE the DuPont™ Tyvek® WRB Field Applied Flanged Door

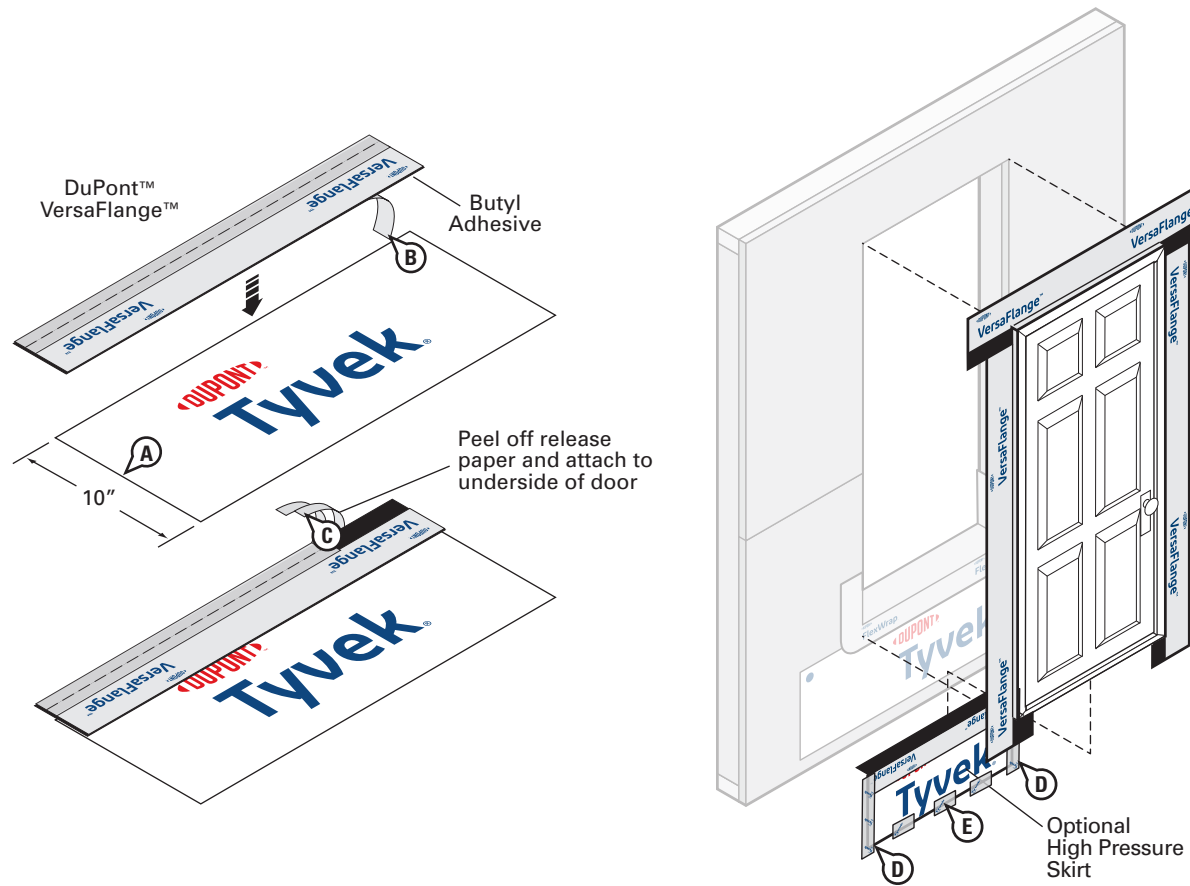

### STEP 9 (OPTIONAL) – HIGH PRESSURE SKIRT

For extreme/coastal exposures, installation of a high-pressure skirt is recommended to help prevent water intrusion at the sill or threshold.

- Create the high pressure skirt by cutting a piece of **Tyvek® WRB** 1" wider than the width of door opening and approximately 10" in height.
- Cut a piece of **DuPont™ VersaFlange™** to the same width of skirt. Remove release paper from one side of the **VersaFlange™** and adhere to **Tyvek® WRB**. The skirt may be made with the **VersaFlange™**, **DuPont™ Flashing Tape**, or **DuPont™ StraightFlash™**.
- Remove the release paper from the other side of the **VersaFlange™** and adhere the butyl adhesive at the sill skirt to the underside of the door threshold behind the jamb flashing.
- After installation of door in Step 10, secure edges of the optional skirt with two 4" pieces of **DuPont™ Tyvek® Tape**, **DuPont™ Flashing Tape**, or **StraightFlash™**.
- Tape the bottom of the optional skirt to allow for drainage and to minimize wind damage during construction.

## Installation Methods for DuPont Self-Adhered Flashing Products Installed BEFORE the DuPont™ Tyvek® WRB Field Applied Flanged Door

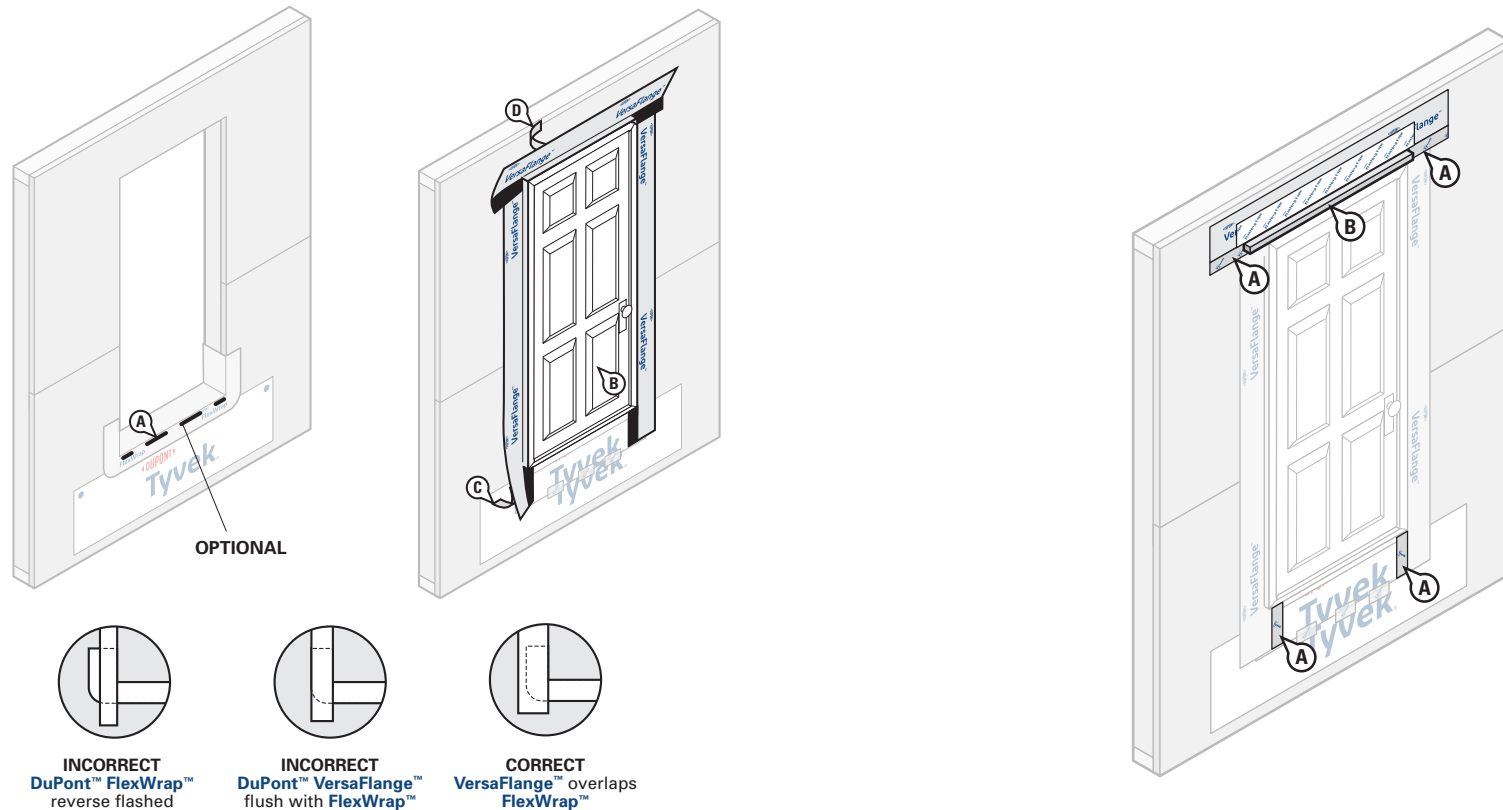

### STEP 10

- A. **OPTIONAL:** Apply Tower® Residential Sealant, or recommended sealant, along the sill as shown above. **To allow for drainage, do not apply continuous sealant bead along sill.** Ensure a minimum 2" wide drainage gap in the sealant bead within 4" from **each corner** of the jamb-sill interface. Continue applying sealant along the sill with additional 2" wide (min.) drainage gaps for every 6"–12" (on center) of sill width.
- B. Install door according to manufacturer's installation instructions.
- C. Remove the remaining release paper from the **DuPont™ VersaFlange™** jamb flashing and press firmly to adhere the butyl adhesive to the exterior sheathing or framing members. **Do not reverse shingle. VersaFlange™** must overlap **DuPont™ FlexWrap™** and adhere to the substrate.
- D. Remove the release paper at the head and adhere the **VersaFlange™** to the exterior sheathing or framing members.

### STEP 11

- A. **OPTIONAL:** Cover exposed butyl with **DuPont™ Tyvek® Tape**, **DuPont™ Flashing Tape**, or **DuPont™ StraightFlash™**.
- B. **OPTIONAL:** If installing a drip cap as part of the door installation BEFORE the **Tyvek® WRB** is installed and sealed, see *Drip Cap Installation* section and refer to [Option 2](#).

## Installation Methods for DuPont Self-Adhered Flashing Products Installed BEFORE the DuPont™ Tyvek® WRB Field Applied Flanged Door

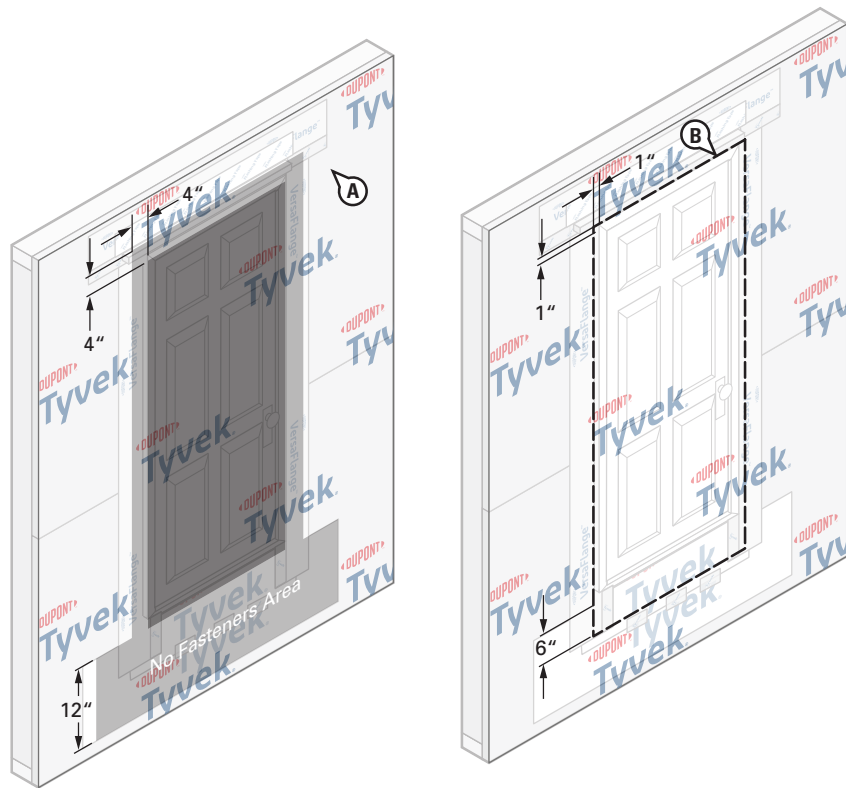

### STEP 12

- A. Install the **Tyvek® WRB** as shown in the [DuPont™ Tyvek® WRB Installation Instructions](#) section of this document. Do not install fasteners within 4" of the door frame at jambs and head and within 12" of the door frame at sill or location of apron.
- B. Mark a perimeter on the **Tyvek® WRB** around the rough opening a minimum of 1" from the jambs and head of the door frame, and 6" below the sill of the door frame.

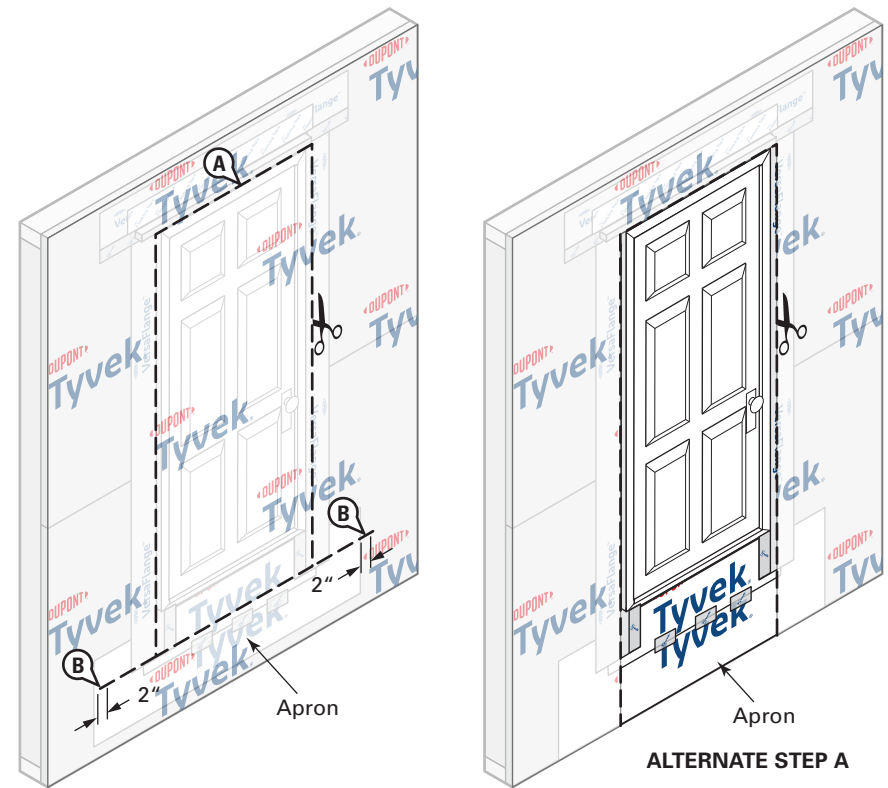

### STEP 13

- A. Cut the **Tyvek® WRB** along perimeter marking to expose door. Do not cut through the **DuPont Self-Adhered Flashing Products** or **Tyvek® WRB** apron underneath.
- ALTERNATE STEP A:** If apron extends far enough below the sill rough opening to overlap the sill plate, base of wall flashing, or the **Tyvek® WRB** below, the **Tyvek® WRB** can be cut along jambs and head only to overlap apron.
- B. Create horizontal slits in the **Tyvek® WRB** at each lower corner of the perimeter cut that extend 1"– 2" **BEYOND** the **Tyvek® WRB** apron.

## Installation Methods for DuPont Self-Adhered Flashing Products Installed BEFORE the DuPont™ Tyvek® WRB Field Applied Flanged Door

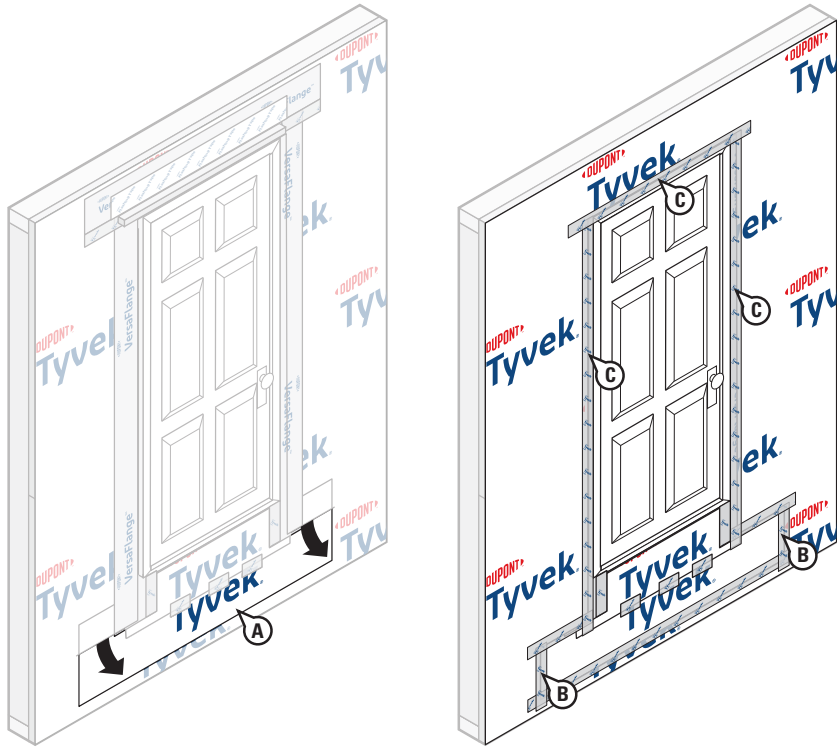

### STEP 14

- Bring the bottom portion of the **Tyvek® WRB** apron through the sill perimeter cut and horizontal slits so it laps over the top layer of **Tyvek® WRB**.
- Working from bottom to top, install **DuPont™ Tyvek® Tape** to secure horizontal and vertical seams of the **Tyvek® WRB** apron.
- Install **Tyvek® Tape** along jambs and head to seal **Tyvek® WRB** around door. For a more robust termination, **DuPont™ Flashing Tape** or **DuPont™ StraightFlash™** can be used. **OPTIONAL:** If installing a drip cap **AFTER** the **Tyvek® WRB** is installed and sealed, see *Drip Cap Installation* section and refer to [Option 3](#).

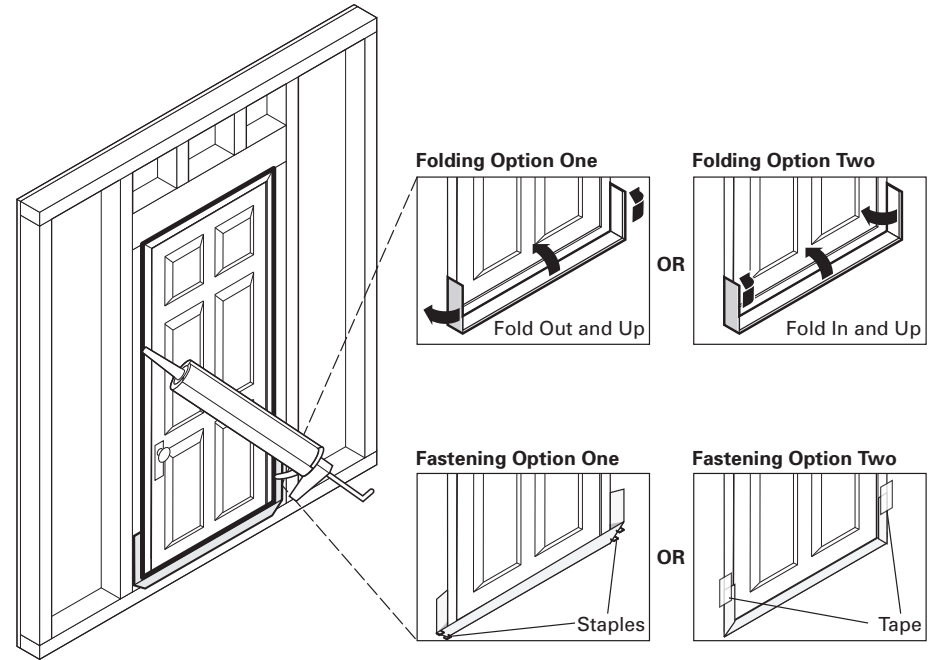

### STEP 15

#### Final Step

- When the interior flooring is ready to install, remove release paper and use Folding Option One or Two (shown above) to form back dam.
- Install Tower® Residential Sealant or recommended sealant (and backer rod as necessary) around the door opening at the interior. It is also acceptable to use **Great Stuff Pro™ Window & Door Polyurethane Foam Sealant**, or recommended foam. When using Tower® Residential Sealant, tool sealant bead flat to allow the natural curing process to create a concave shape. Be sure that the sealant penetrates the grooves of the **DuPont™ FlexWrap™** around the sill. When using **Great Stuff Pro™ Window & Door Polyurethane Foam Sealant** in perimeter openings less than 1/2", apply using the plastic extension tip for the **Great Stuff Pro™ Dispensing Gun** during installation.

## Installation Methods for DuPont Self-Adhered Flashing Products Installed BEFORE the DuPont™ Tyvek® WRB Brick Mold Window

This method applies to the following products: DuPont™ Flashing Tape, DuPont™ StraightFlash™, DuPont™ VersaFlange™, and DuPont™ FlexWrap™

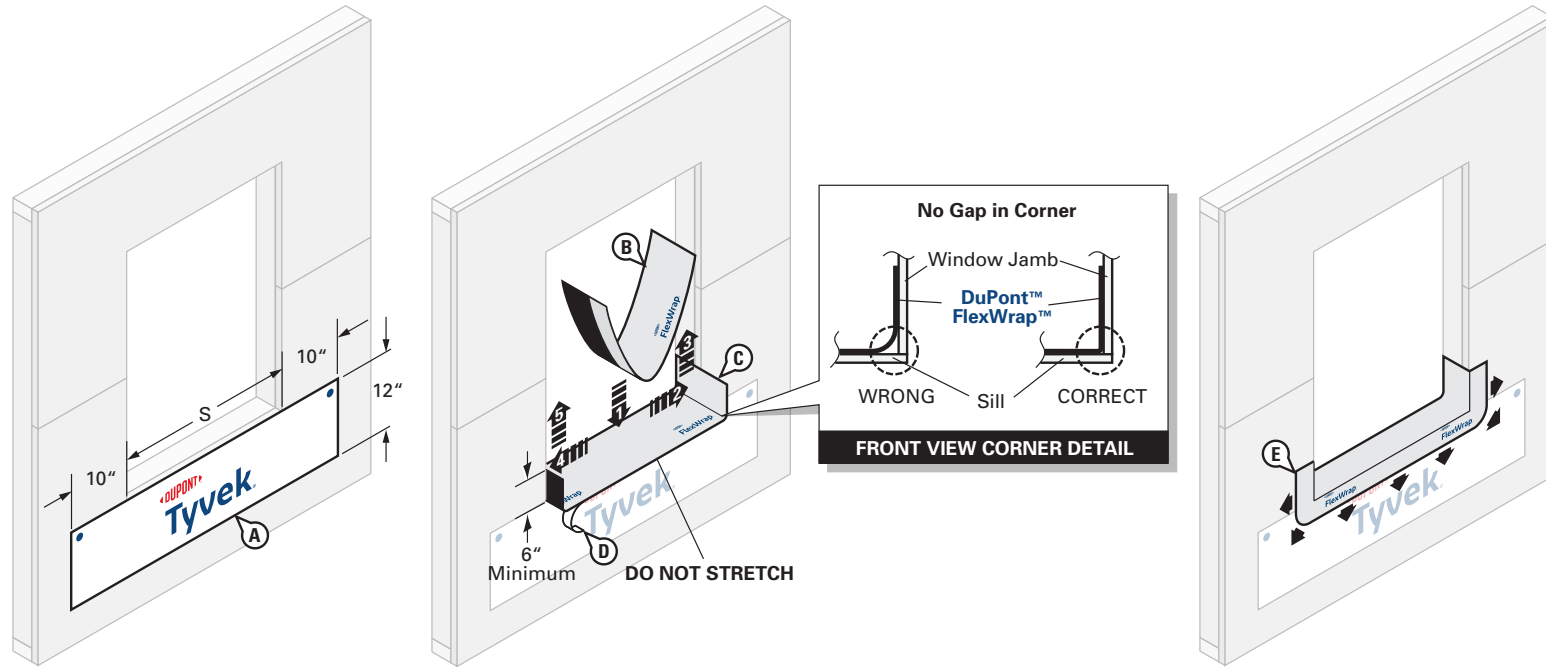

### STEP 1

- Cut an apron made of Tyvek® WRB for attachment under sill of rough opening. Apron should extend at least 10" **BEYOND** the sides of rough opening jambs (or to first stud in open stud construction) and at least 12" below sill of rough opening, or extend far enough below the sill rough opening to overlap the sill plate, base of wall flashing, or the Tyvek® WRB below. The top of the apron should be securely attached to the wall and the bottom of the apron should be left unsecured so it can overlap the Tyvek® WRB which will be installed after the window. Avoid placing DuPont™ Tyvek® Wrap Cap Fasteners where DuPont Self-Adhered Flashing Products will be installed.
- Cut FlexWrap™ at least 12" **LONGER** than width of rough opening sill (S). Use roll widths sufficient to achieve a minimum of 1" adhesion **BEYOND** where the window frame will be located, ensuring 2"- 3" adhesion onto the face of the wall.
- Remove wide piece of release paper. Position on horizontal sill by aligning the inside edge of the narrow release paper with the face of the wall to ensure 2"- 3" of the FlexWrap™ will be adhered to the face of the wall with a minimum of 6" up each jamb. Adhere into rough opening.
- Remove narrow release paper.
- Fan out the FlexWrap™ at corners and adhere onto face of wall. Continue adhering onto face of wall along sill.

## Installation Methods for DuPont Self-Adhered Flashing Products Installed BEFORE the DuPont™ Tyvek® WRB

### Brick Mold Window

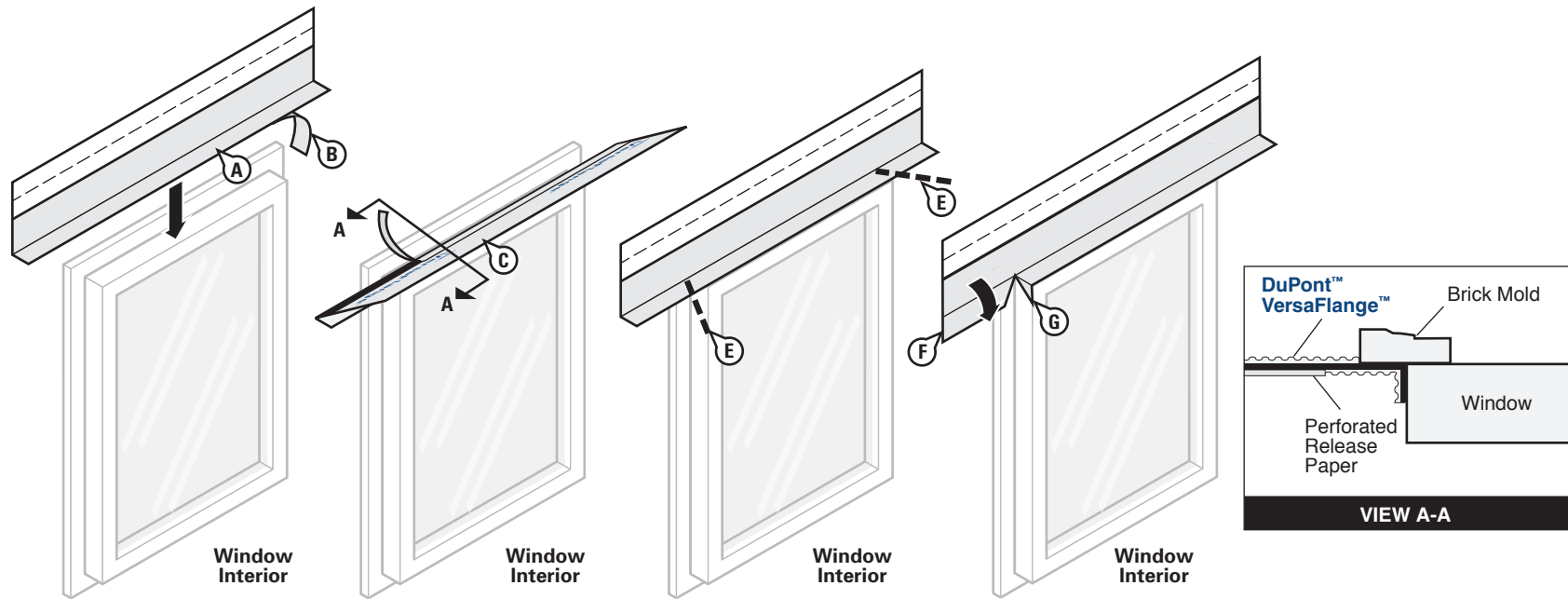

## STEP 2

- Prepare head flashing by cutting a piece of **DuPont™ VersaFlange™** at least 12" **LONGER** than the head length.
- Break the perforated release paper on one side of the head flashing by folding it back and forth upon itself.
- Center the **VersaFlange™** along the length of the window head and position so that it contacts the window frame and interior side of the brick mold. Remove the outer release paper and adhere the flashing to the window frame. Use the inner release paper to form a tight seal in the corner.
- Remove the inner release paper and adhere the flashing to the back of the brick mold.
- Beginning at the junction of the jamb and the head, and away from the corner, cut **VersaFlange™** at a 45° angle.
- Fold the newly created flaps down against the brick mold.
- Fold remaining head flashing flaps down onto the jamb.



## Installation Methods for DuPont Self-Adhered Flashing Products Installed BEFORE the DuPont™ Tyvek® WRB

### Brick Mold Window

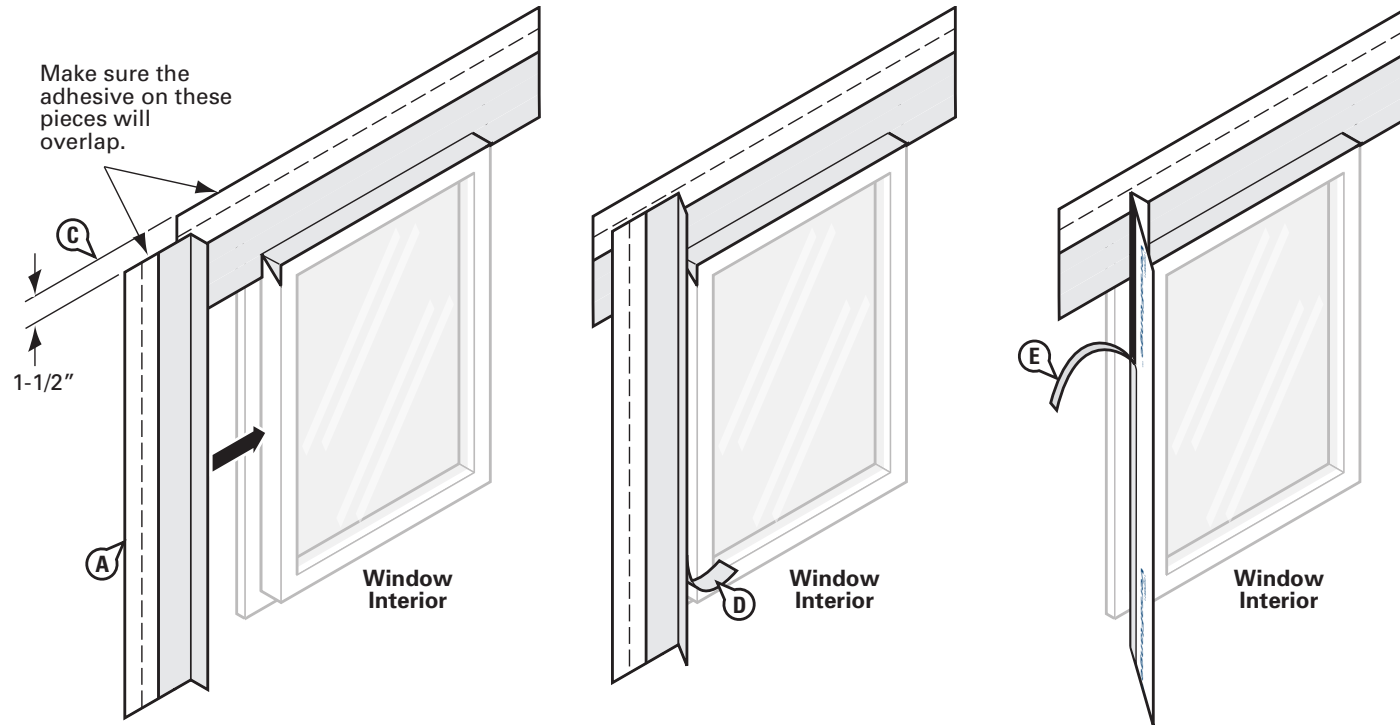

### STEP 3

- A. Prepare jamb flashing by cutting a piece of **DuPont™ VersaFlange™** at least 6" **LONGER** than the jamb.
- B. Break the perforated release paper on one side of the jamb flashing by folding it back and forth upon itself.
- C. Position so that the **VersaFlange™** contacts the window frame and interior side of the brick mold. Ensure that the jamb flashing is positioned 1-1/2" below the top edge of the head flashing. **Jamb flashing adhesive must come in contact with head flashing adhesive and overlap 1"**.
- D. Remove the outer release paper and adhere the flashing to the window frame. Use the inner release paper to form a tight seal in the corner.
- E. Remove the inner release paper and adhere the flashing to the back of the brick mold.
- F. Repeat on opposite jamb.

## Installation Methods for DuPont Self-Adhered Flashing Products Installed BEFORE the DuPont™ Tyvek® WRB

### Brick Mold Window

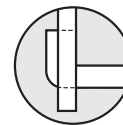
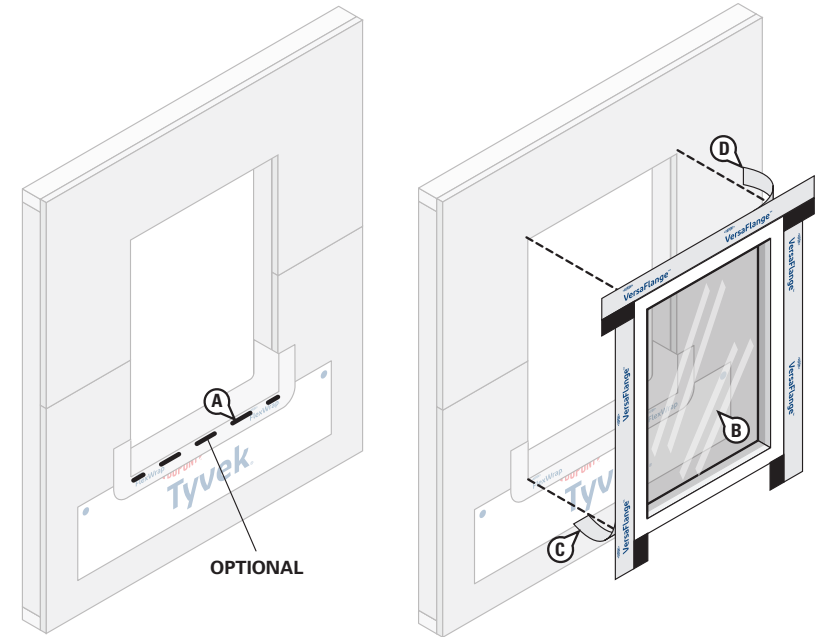
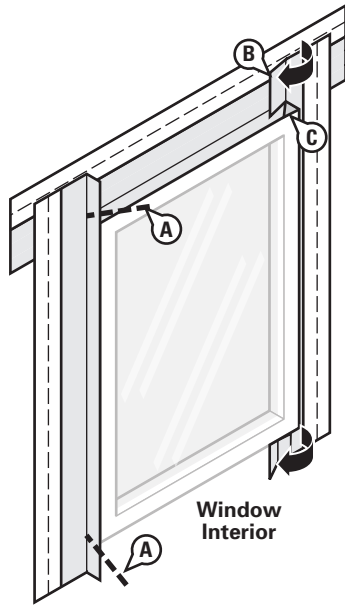

**INCORRECT**  
DuPont™ FlexWrap™  
reverse flashed

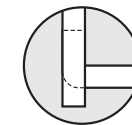

**INCORRECT**  
DuPont™ VersaFlange™  
flush with FlexWrap™

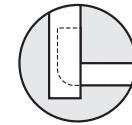

**CORRECT**  
VersaFlange™ overlaps  
FlexWrap™

#### STEP 4

- Beginning at the junction of the jamb and the head, and away from the corner, cut the **DuPont™ VersaFlange™** at a 45° angle. Repeat the procedure at the junction of the sill and jambs.
- In order to overlap jamb adhesive to the head flashing adhesive, temporarily pull back release liner on the head flashing. Fold cut jamb flashing parallel to the window frame so that the jamb flashing lies flat onto the head flashing. Fold the head flashing release liner back down to protect any remaining exposed butyl along the head flashing prior to installation of the window.
- Fold remaining jamb flashing flaps down at all corners and adhere to the window frame.

#### STEP 5

- OPTIONAL:** Apply Tower® Residential Sealant, or recommended sealant, along the sill as shown above. **To allow for drainage, do not apply continuous sealant bead along sill.** Ensure a minimum 2" wide drainage gap in the sealant bead within 4" from **each corner** of the jamb-sill interface. Continue applying sealant along the sill with additional 2" wide (min.) drainage gaps for every 6"– 12" (on center) of sill width.
- Install window according to manufacturer's installation instructions.
- Remove the remaining release paper from the **VersaFlange™** jamb flashing and press firmly to adhere the butyl adhesive to the exterior sheathing or framing members. **Do not reverse shingle. VersaFlange™** must overlap **DuPont™ FlexWrap™** and adhere to the substrate.
- Remove the release paper at the head and adhere the **VersaFlange™** to the exterior sheathing or framing members.

## Installation Methods for DuPont Self-Adhered Flashing Products Installed BEFORE the DuPont™ Tyvek® WRB Brick Mold Window

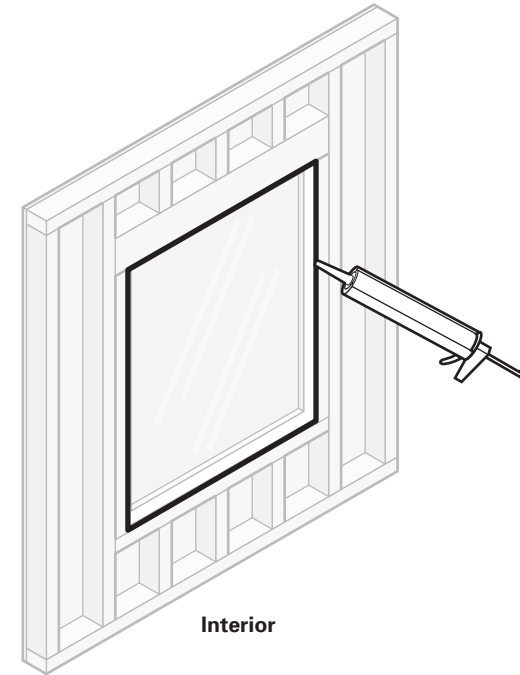
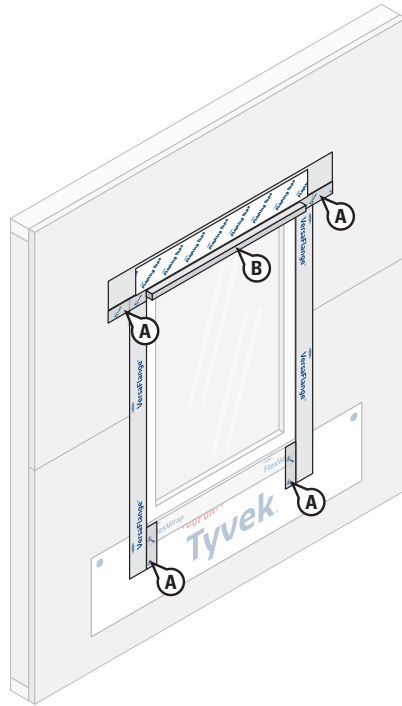

### STEP 6

- A. **OPTIONAL:** Cover exposed butyl with **DuPont™ Tyvek® Tape**, **DuPont™ Flashing Tape**, or **DuPont™ StraightFlash™**.
- B. **OPTIONAL:** If installing a drip cap as part of the window installation BEFORE the **DuPont™ Tyvek® WRB** is installed and sealed, see *Drip Cap Installation* section and refer to [Option 2](#).

### STEP 7

Install Tower® Residential Sealant or recommended sealant (and backer rod as necessary) around the window opening at the interior. It is also acceptable to use **Great Stuff Pro™ Window & Door Polyurethane Foam Sealant**, or recommended foam. When using Tower® Residential Sealant, tool sealant bead flat to allow the natural curing process to create a concave shape. Be sure that the sealant penetrates the grooves of the **FlexWrap™** around the sill. When using **Great Stuff Pro™ Window & Door Polyurethane Foam Sealant** in perimeter openings less than 1/2", apply using the plastic extension tip for the **Great Stuff Pro™ Dispensing Gun** during installation.

## Installation Methods for DuPont Self-Adhered Flashing Products Installed BEFORE the DuPont™ Tyvek® WRB Brick Mold Window

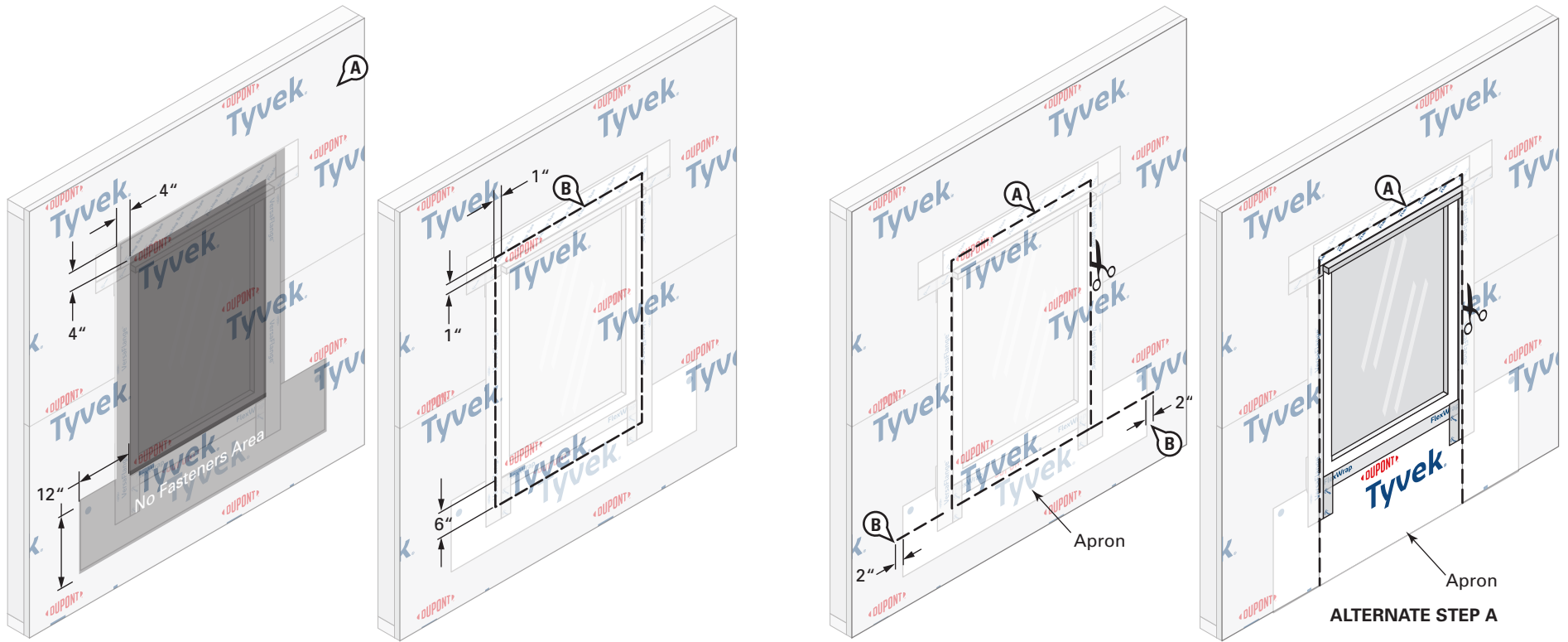

### STEP 8

- Install the **Tyvek® WRB** as shown in the [DuPont™ Tyvek® WRB Installation Instructions](#) section of this document. Do not install fasteners within 4" of the window frame at jambs and head and within 12" of the window frame at sill or location of apron.
- Mark a perimeter on the **Tyvek® WRB** around the rough opening a minimum of 1" from the jambs and head of the window frame, and 6" below the sill of the window frame.

### STEP 9

- Cut the **Tyvek® WRB** along perimeter marking to expose window. Do not cut through the **DuPont Self-Adhered Flashing Products** or **Tyvek® WRB** apron underneath.

**ALTERNATE STEP A:** If apron extends far enough below the sill rough opening to overlap the sill plate, base of wall flashing, or the **Tyvek® WRB** below, the **Tyvek® WRB** can be cut along jambs and head only to overlap apron.

- Create horizontal slits in the **Tyvek® WRB** at each lower corner of the perimeter cut that extend 1"– 2" **BEYOND** the **Tyvek® WRB** apron.

## Installation Methods for DuPont Self-Adhered Flashing Products Installed BEFORE the DuPont™ Tyvek® WRB Brick Mold Window

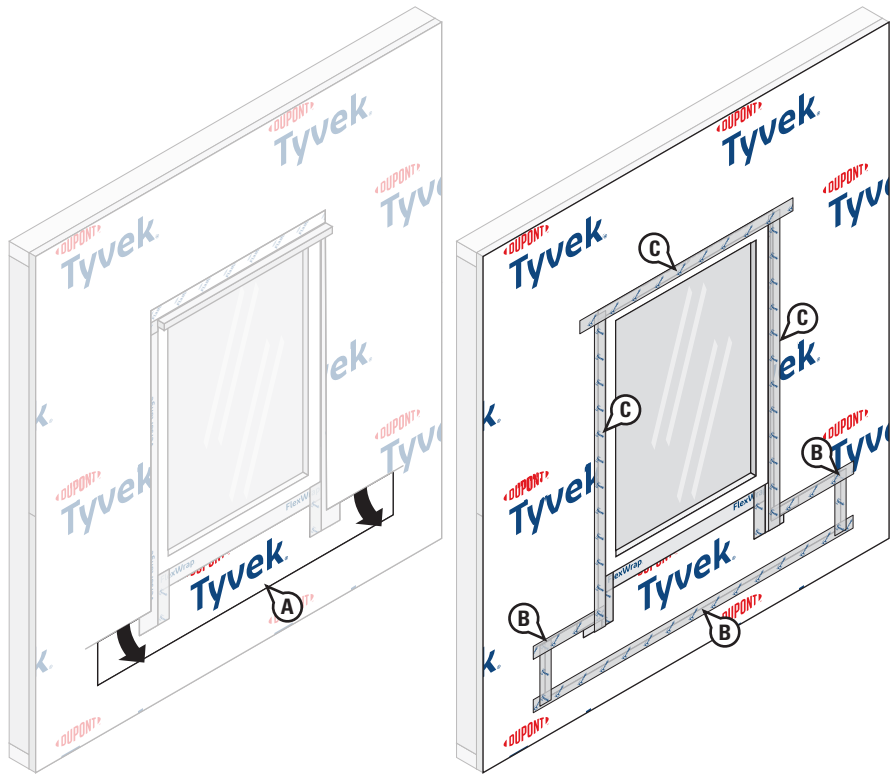

### STEP 10

#### Final Step

- A. Bring the bottom portion of the **Tyvek® WRB** apron through the sill perimeter cut and horizontal slits so it laps over the top layer of **Tyvek® WRB**.
- B. Working from bottom to top, install **DuPont™ Tyvek® Tape** to secure horizontal and vertical seams of the **Tyvek® WRB** apron.
- C. Install **Tyvek® Tape** along jambs and head to seal **Tyvek® WRB** around window. For a more robust termination, **DuPont™ Flashing Tape** or **DuPont™ StraightFlash™** can be used. **OPTIONAL:** If installing a drip cap **AFTER** the **Tyvek® WRB** is installed and sealed, see *Drip Cap Installation* section and refer to [Option 3](#).

## Installation Methods for DuPont Self-Adhered Flashing Products Installed BEFORE the DuPont™ Tyvek® WRB Brick Mold Door

This installation guide is intended for doors installed above grade and/or with wood floor construction.

This method applies to the following products: DuPont™ Flashing Tape, DuPont™ StraightFlash™, DuPont™ VersaFlange™ and DuPont™ FlexWrap™

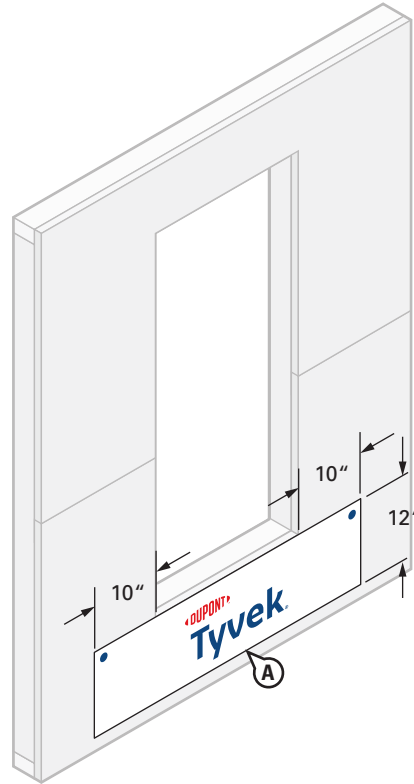

---

### STEP 1

#### Prepare Tyvek® WRB Apron

- A. Cut an apron made of Tyvek® WRB for attachment under sill of rough opening. Apron should extend at least 10" **BEYOND** the sides of rough opening jambs (or to first stud in open stud construction) and at least 12" below sill of rough opening, or extend far enough below the sill rough opening to overlap the sill plate, base of wall flashing, or the Tyvek® WRB below. The top of the apron should be securely attached to the wall and the bottom of the apron should be left unsecured so it can overlap the Tyvek® WRB which will be installed after the door. Avoid placing DuPont™ Tyvek® Wrap Cap Fasteners where DuPont Self-Adhered Flashing Products will be installed.

## Installation Methods for DuPont Self-Adhered Flashing Products Installed BEFORE the DuPont™ Tyvek® WRB

### Brick Mold Door

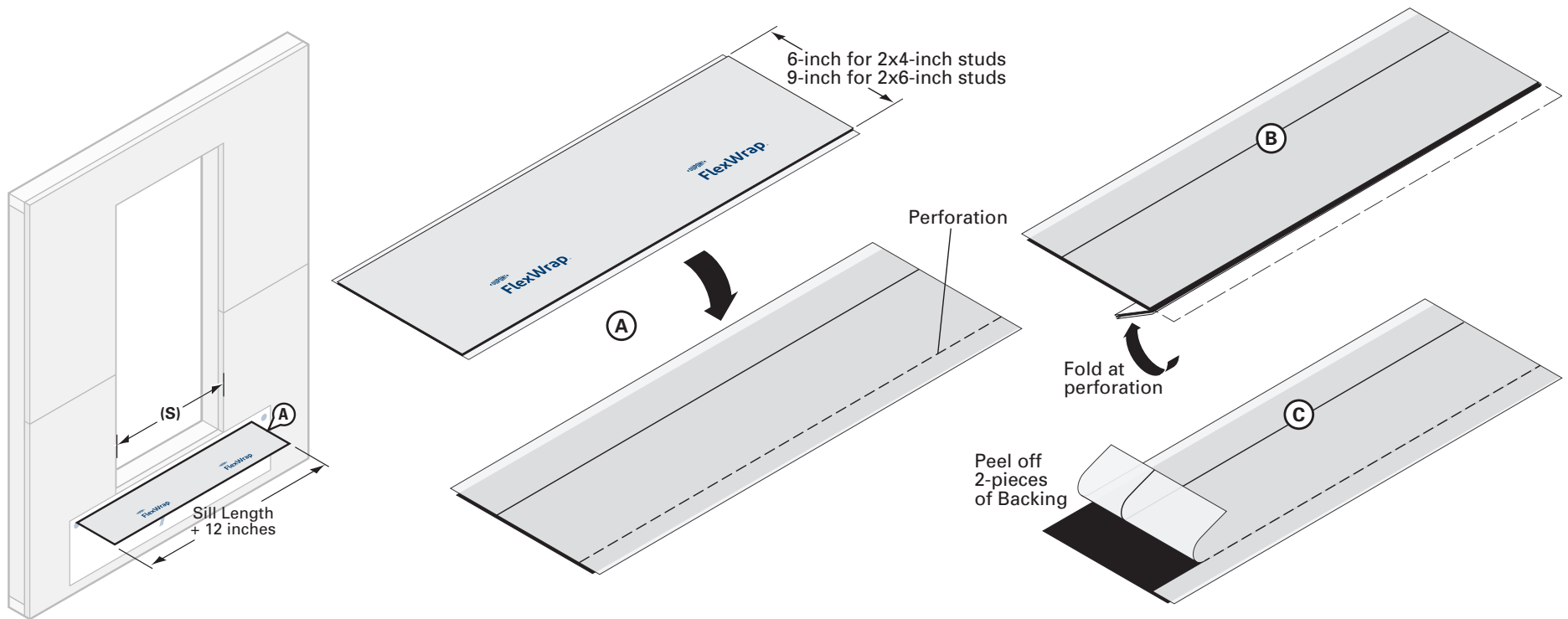

## STEP 2

### Preparation of Sill Flashing

- A. Cut a piece of 9" wide DuPont™ FlexWrap™ at least 12" **LONGER** than the width of the sill (S).
- B. 9" FlexWrap™ has perforated release paper to help with the formation of a back dam. To ensure that the perforation tears cleanly, fold the perforation 180° and create the flashing.
- C. Remove the widest pieces of release paper leaving the narrowest release paper on the flashing. When the finished floor is applied, the release paper can be removed and the back dam can be completed.

## Installation Methods for DuPont Self-Adhered Flashing Products Installed BEFORE the DuPont™ Tyvek® WRB Brick Mold Door

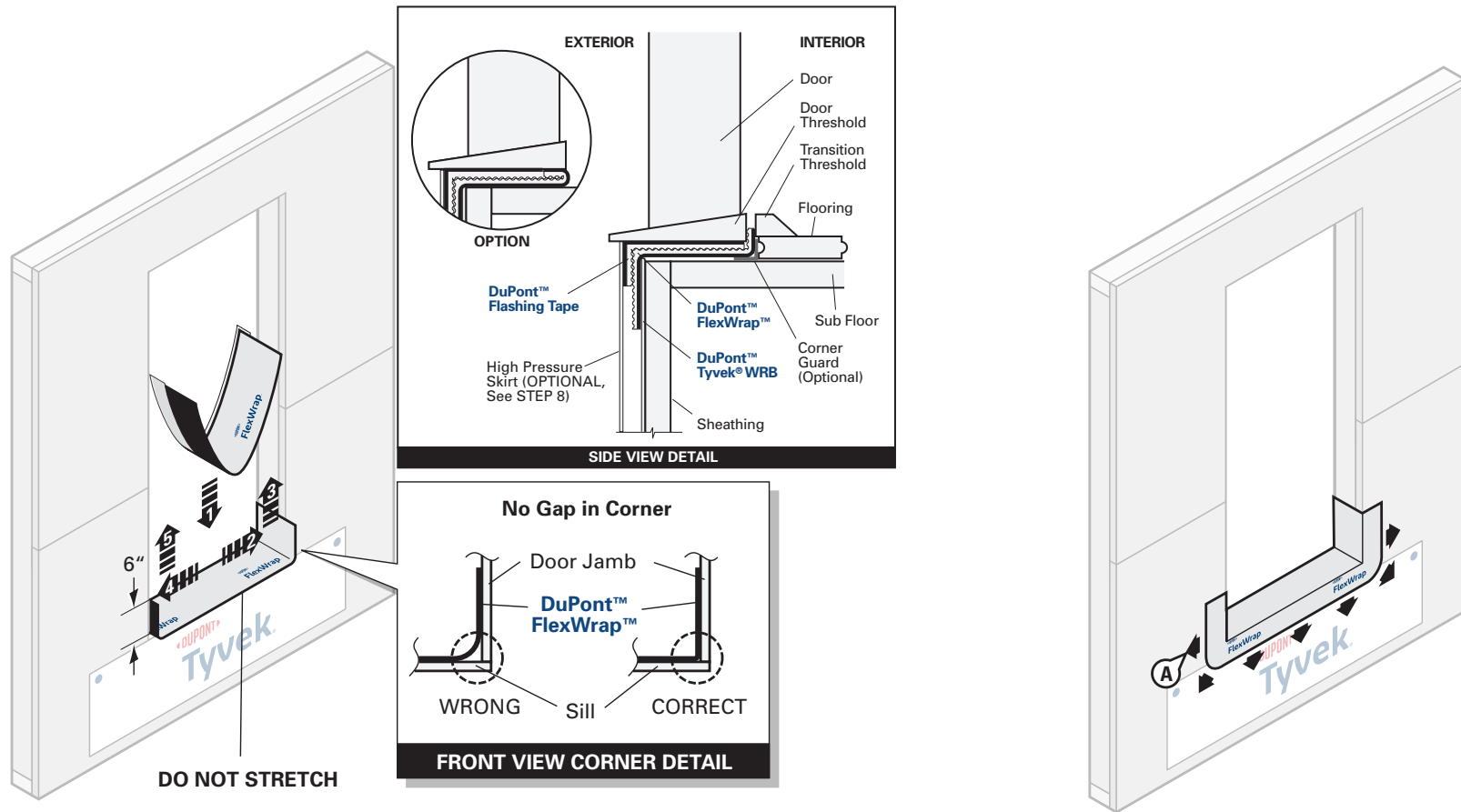

### STEP 3

- A. Position the sill flashing as indicated so the section with the release paper still attached extends past the door threshold on the inside. Ensure that 2"– 3" of the **DuPont™ FlexWrap™** will be adhered to the face of the wall with a minimum of 6" up each jamb. Adhere into rough opening. When the 1" of release paper is removed, the remaining section of **FlexWrap™** can be used to form a back dam.

**OPTIONAL: Create back dam by folding back narrow section of FlexWrap™.** Some flooring cannot accommodate a back dam. In that case fold the back dam on top of **FlexWrap™** in the sill. The door will be installed on top of the fold to create a back dam (see Side View Detail above).

### STEP 4

- A. Fan out the **FlexWrap™** at corners and adhere onto face of wall. Continue adhering onto face of wall along sill.



## Installation Methods for DuPont Self-Adhered Flashing Products Installed BEFORE the DuPont™ Tyvek® WRB

### Brick Mold Door

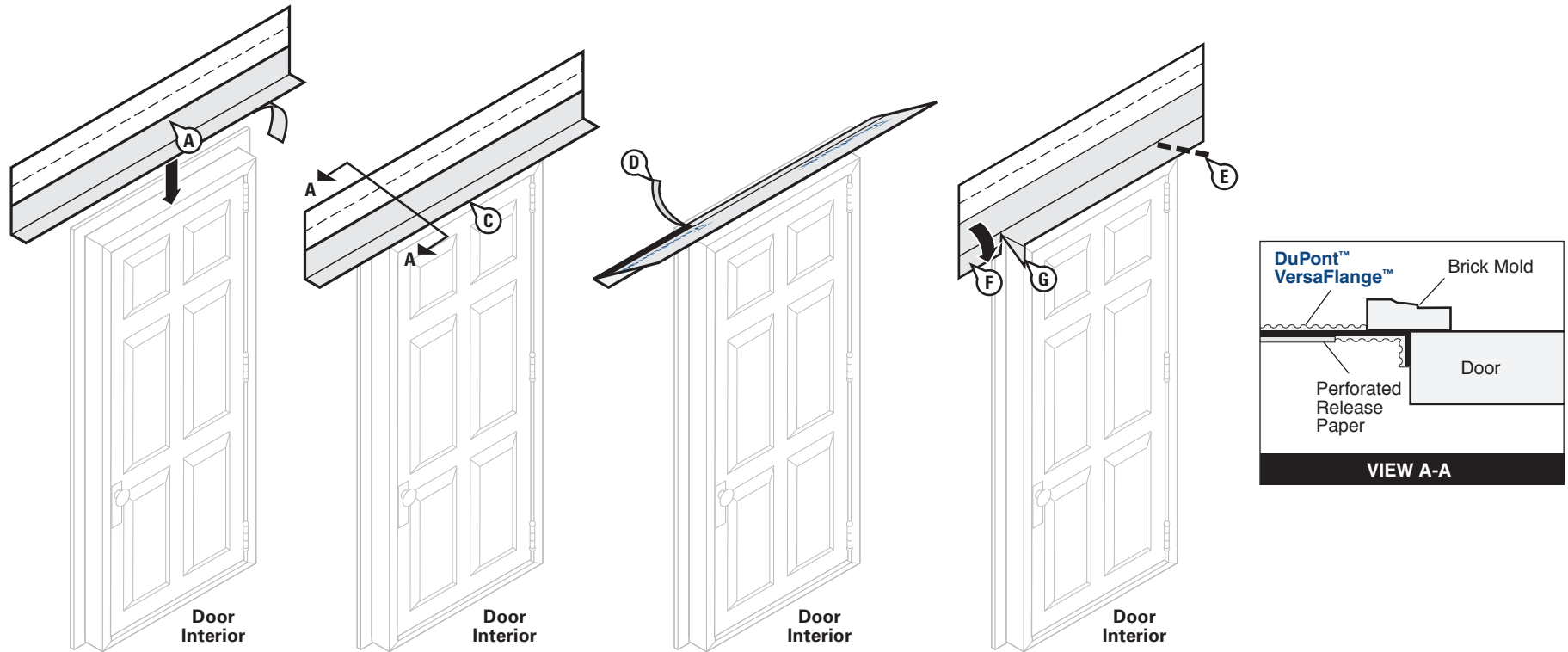

### STEP 5

- A. Prepare head flashing by cutting a piece of **DuPont™ VersaFlange™** at least 12" **LONGER** than the head length.
- B. Break the perforated release paper on one edge of the head flashing by folding it back and forth upon itself.
- C. Center the **VersaFlange™** along the length of the door head and position so that it contacts the door frame and interior side of the brick mold. Remove the outer release paper and adhere the flashing to the door frame. Use the inner release paper to form a tight seal in the corner.
- D. Remove the inner release paper and adhere the flashing to the back of the brick mold.
- E. At the corner of the door frame, cut the **VersaFlange™** at a 45° angle.
- F. Fold the newly created flashing flap down flat against the brick mold.
- G. Fold remaining head flashing flaps down onto the jamb frame.

## Installation Methods for DuPont Self-Adhered Flashing Products Installed BEFORE the DuPont™ Tyvek® WRB

### Brick Mold Door

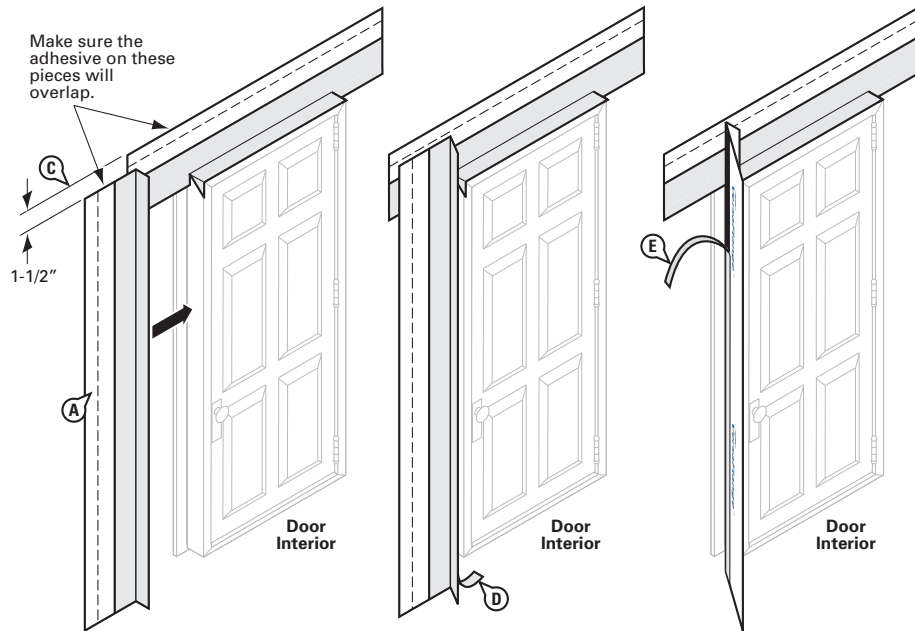

#### STEP 6

- Prepare jamb flashing by cutting a piece of **DuPont™ VersaFlange™** at least 6" **LONGER** than the jamb.
- Break the perforated release paper on one side of the jamb flashing by folding it back and forth upon itself.
- Position so that **VersaFlange™** contacts the door frame and interior side of the brick mold. Ensure that the jamb flashing is positioned 1-1/2" below the top edge of the head flashing. **Jamb flashing adhesive must come in contact with head flashing adhesive by 1"**.
- Remove the outer release paper and adhere the flashing to the door frame. Use the inner release paper to form a tight seal in the corner.
- Remove the inner release paper and adhere the flashing to the back of the brick mold.
- Repeat on opposite jamb.

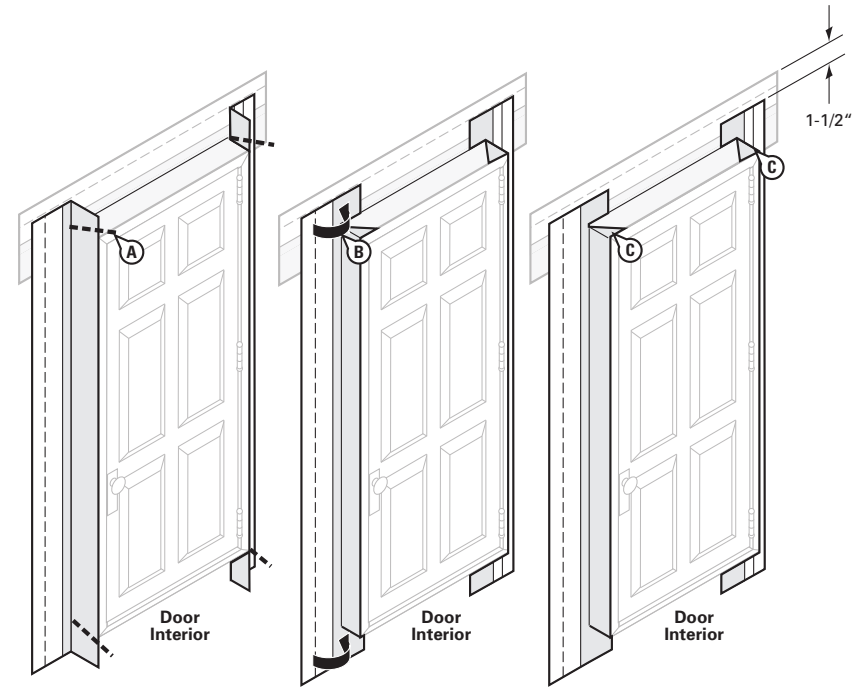

#### STEP 7

- Beginning at the junction of the jamb and head, and away from the corner, cut the **VersaFlange™** at a 45° angle. Repeat the procedure at the junction of the sill and jamb.
- In order to overlap jamb adhesive to the head flashing adhesive, temporarily pull back release liner on the head flashing. Fold cut jamb flashing parallel to the door frame so that the jamb flashing lies flat onto the head flashing. Fold the head flashing release liner back down to protect any remaining exposed butyl along the head flashing prior to installation of the door.
- Fold remaining jamb flashing flaps down at all corners and adhere to the door frame.

## Installation Methods for DuPont Self-Adhered Flashing Products Installed BEFORE the DuPont™ Tyvek® WRB Brick Mold Door

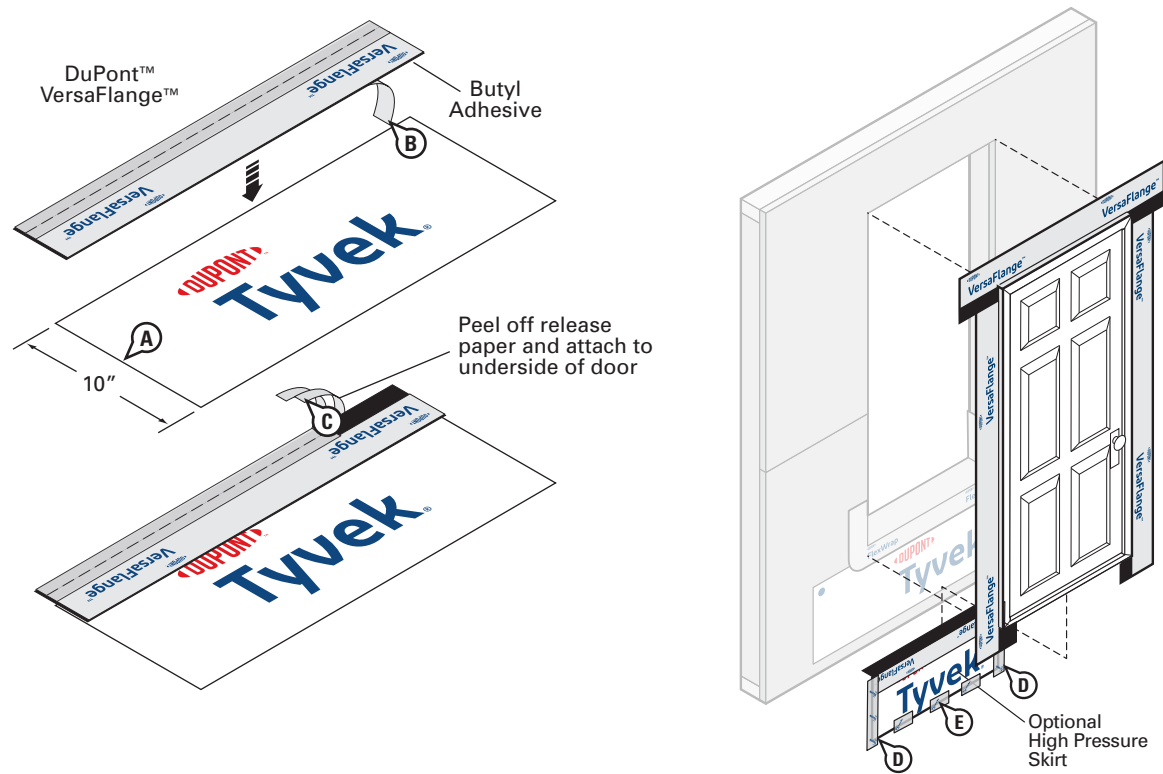

### STEP 8 (OPTIONAL - HIGH PRESSURE SKIRT)

For extreme/coastal exposures, installation of a high-pressure skirt is recommended to help prevent water intrusion at the sill or threshold.

- Create the high pressure skirt by cutting a piece of **Tyvek® WRB** 1" **WIDER** than the width of the door opening and approximately 10" in height.
- Cut a piece of **DuPont™ VersaFlange™** to the same width of skirt. Remove release paper from one side of the **VersaFlange™** and adhere to the **Tyvek® WRB**. The skirt may be made with **VersaFlange™**, **DuPont™ Flashing Tape**, or **StraightFlash™**.
- Remove the release paper from the other side of the **VersaFlange™** and adhere the butyl adhesive at the sill skirt to the underside of the door threshold behind the jamb flashing.
- After installation of door in Step 9, secure edges of the optional skirt with two 4" pieces of **DuPont™ Tyvek® Tape**, **DuPont™ Flashing Tape**, or **StraightFlash™**.
- Tape the bottom of the optional skirt to allow for drainage and to minimize wind damage during construction.

## Installation Methods for DuPont Self-Adhered Flashing Products Installed BEFORE the DuPont™ Tyvek® WRB Brick Mold Door

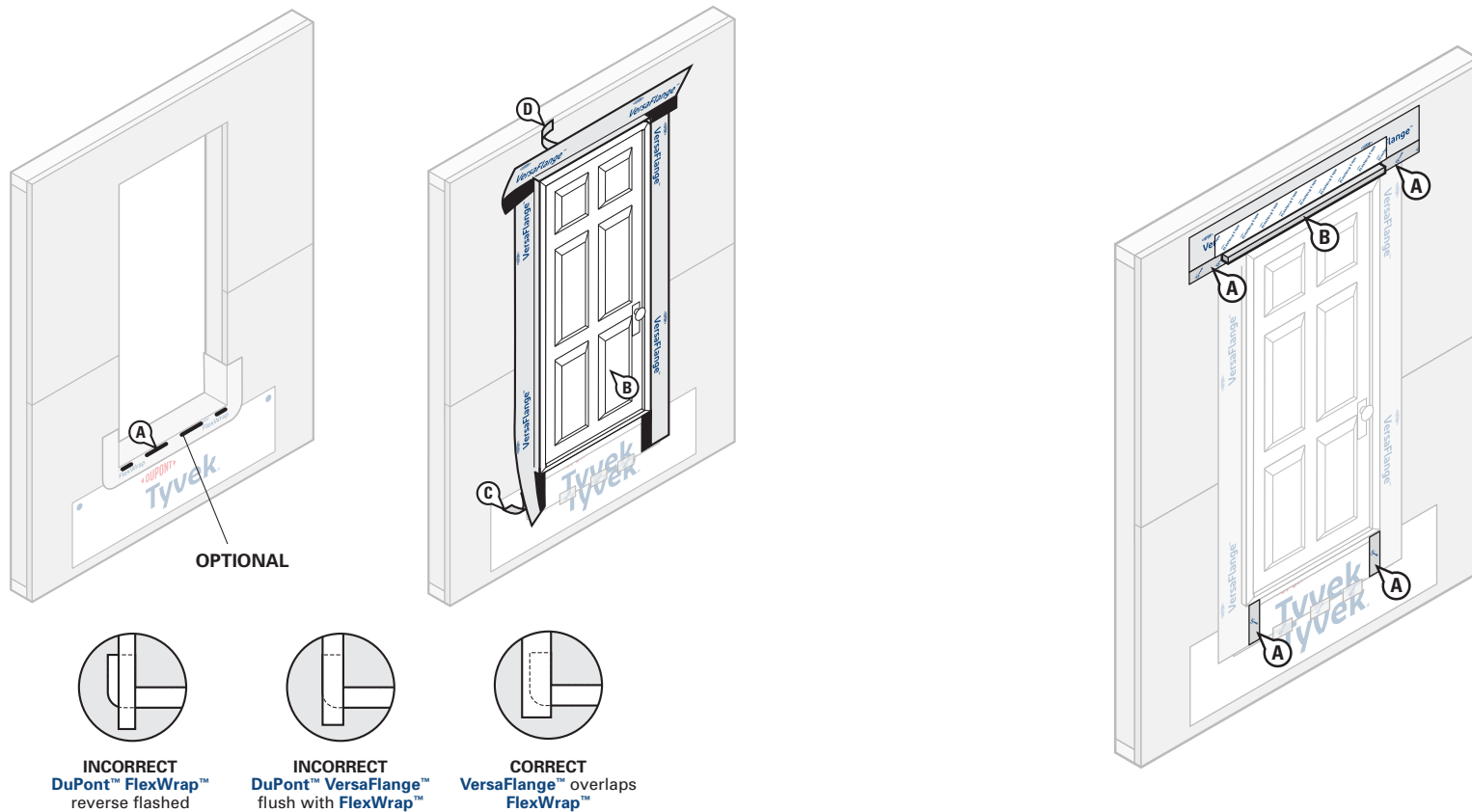

### STEP 9

- OPTIONAL:** Apply Tower® Residential Sealant, or recommended sealant, along the sill as shown above. **To allow for drainage, do not apply continuous sealant bead along sill.** Ensure a minimum 2" wide drainage gap in the sealant bead within 4" from **each corner** of the jamb-sill interface. Continue applying sealant along the sill with additional 2" wide (min.) drainage gaps for every 6"– 12" (on center) of sill width.
- Install door according to manufacturer's installation instructions.
- Remove the remaining release paper from the **DuPont™ VersaFlange™** jamb flashing and press firmly to adhere the butyl adhesive to the exterior sheathing or framing members. **Do not reverse shingle. VersaFlange™** must overlap **DuPont™ FlexWrap™** and adhere to the substrate.
- Remove the release paper at the head and adhere the **VersaFlange™** to the exterior sheathing or framing members.

### STEP 10

- OPTIONAL:** Cover exposed butyl with **DuPont™ Tyvek® Tape, DuPont™ Flashing Tape, or DuPont™ StraightFlash™.**
- OPTIONAL:** If installing a drip cap as part of the door installation **BEFORE** the **Tyvek® WRB** is installed and sealed, see *Drip Cap Installation* section and refer to [Option 2](#).

## Installation Methods for DuPont Self-Adhered Flashing Products Installed BEFORE the DuPont™ Tyvek® WRB Brick Mold Door

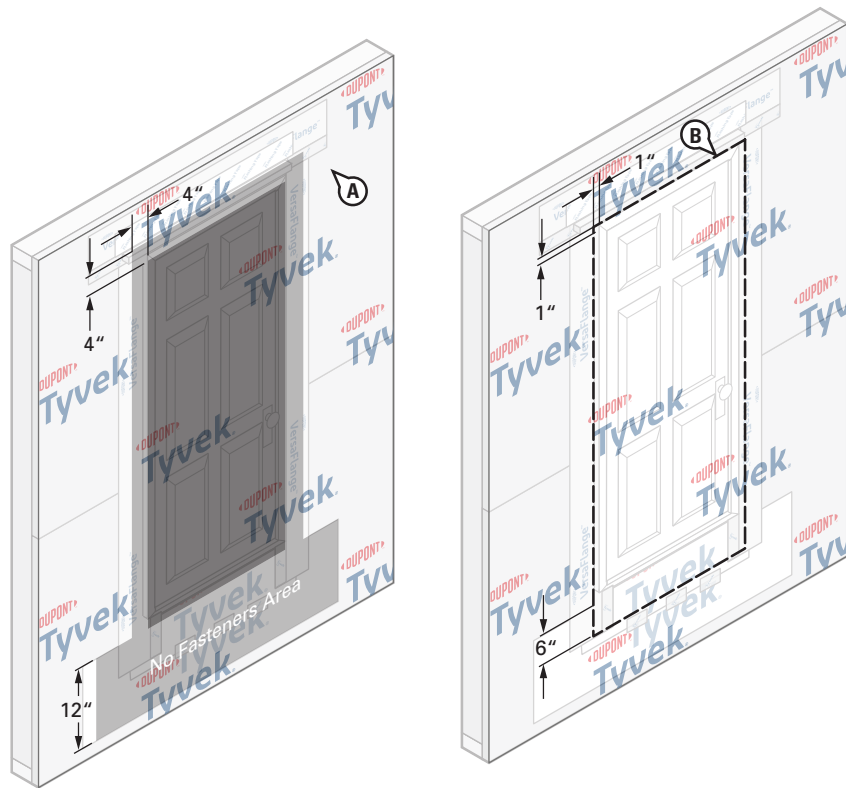

### STEP 11

- A. Install the **Tyvek® WRB** as shown in the [DuPont™ Tyvek® WRB Installation Instructions](#) section of this document. Do not install fasteners within 4" of the door frame at jambs and head and within 12" of the door frame at sill or location of apron.
- B. Mark a perimeter on the **Tyvek® WRB** around the rough opening a minimum of 1" from the jambs and head of the door frame, and 6" below the sill of the door frame.

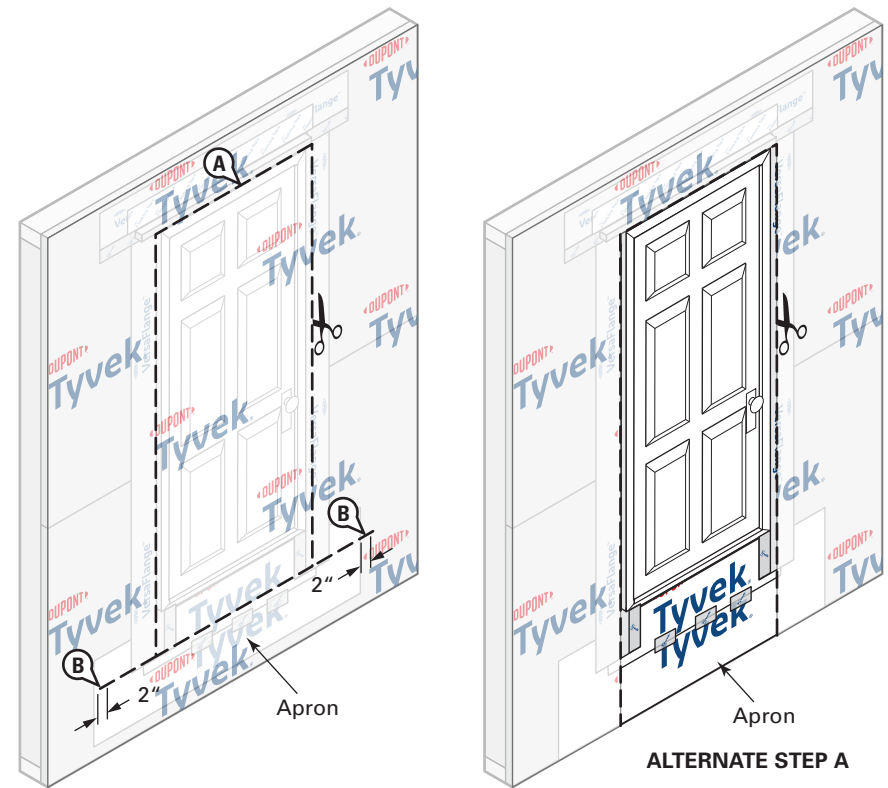

### STEP 12

- A. Cut the **Tyvek® WRB** along perimeter marking to expose door. Do not cut through the **DuPont Self-Adhered Flashing Products** or **Tyvek® WRB** apron underneath.
- ALTERNATE STEP A:** If apron extends far enough below the sill rough opening to overlap the sill plate, base of wall flashing, or the **Tyvek® WRB** below, the **Tyvek® WRB** can be cut along jambs and head only to overlap apron.
- B. Create horizontal slits in the **Tyvek® WRB** at each lower corner of the perimeter cut that extend 1"– 2" **BEYOND** the **Tyvek® WRB** apron.

## Installation Methods for DuPont Self-Adhered Flashing Products Installed BEFORE the DuPont™ Tyvek® WRB Brick Mold Door

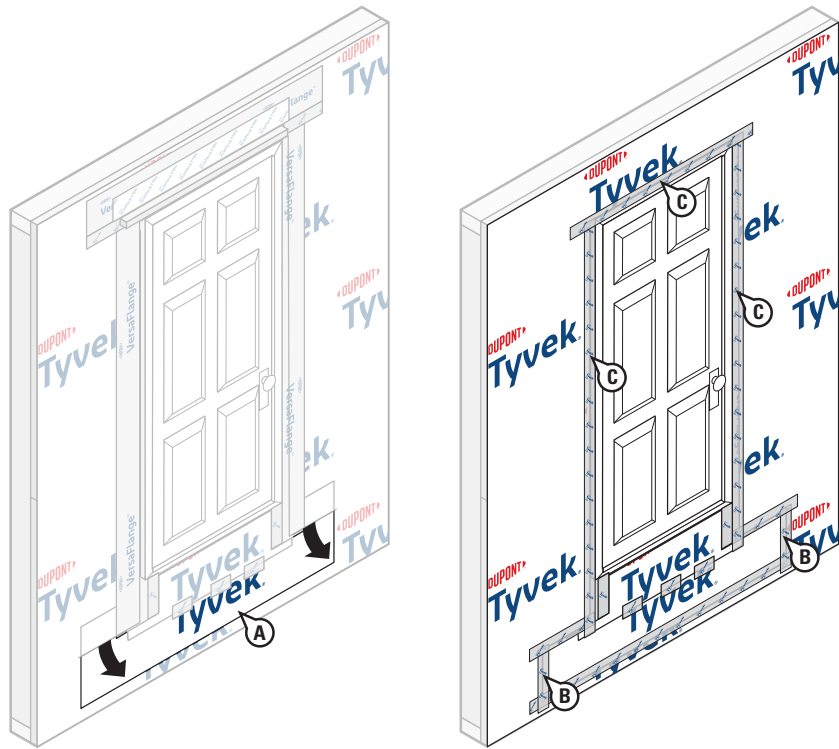

### STEP 13

- A. Bring the bottom portion of the **Tyvek® WRB** apron through the sill perimeter cut and horizontal slits so it laps over the top layer of **Tyvek® WRB**.
- B. Working from bottom to top, install **DuPont™ Tyvek® Tape** to secure horizontal and vertical seams of the **Tyvek® WRB** apron.
- C. Install **Tyvek® Tape** along jambs and head to seal **Tyvek® WRB** around door. For a more robust termination, **DuPont™ Flashing Tape** or **DuPont™ StraightFlash™** can be used. **OPTIONAL:** If installing a drip cap **AFTER** the **Tyvek® WRB** is installed and sealed, see *Drip Cap Installation* section and refer to [Option 3](#).

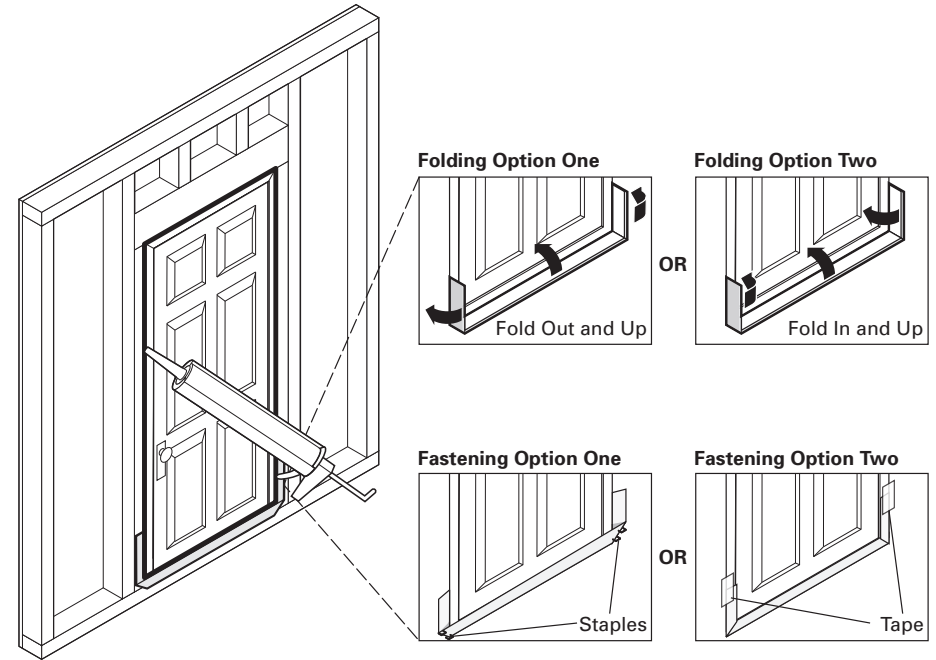

### STEP 14

#### Final Step

- A. When the interior flooring is ready to install, remove release paper and use Folding Option One or Two (shown above) to form back dam.
- B. Install Tower® Residential Sealant or recommended sealant (and backer rod as necessary) around the door opening at the interior. It is also acceptable to use **Great Stuff Pro™ Window & Door Polyurethane Foam Sealant**, or recommended foam. When using Tower® Residential Sealant, tool sealant bead flat to allow the natural curing process to create a concave shape. Be sure that the sealant penetrates the grooves of the **DuPont™ FlexWrap™** around the sill. When using **Great Stuff Pro™ Window & Door Polyurethane Foam Sealant** in perimeter openings less than 1/2", apply using the plastic extension tip for the **Great Stuff Pro™ Dispensing Gun** during installation.

## Installation Methods for DuPont Self-Adhered Flashing Products Installed BEFORE the DuPont™ Tyvek® WRB

### Integral Flanged Window – “Pre-Strip” Methods

Alternate Installation For Rough Opening Air Barrier Continuity and Head Drainage Detail

This method applies to the following products: DuPont™ Flashing Tape, DuPont™ FlexWrap™ and DuPont™ StraightFlash™

#### Method 1 – Rough Opening Treatment With Single Piece of Tyvek® WRB

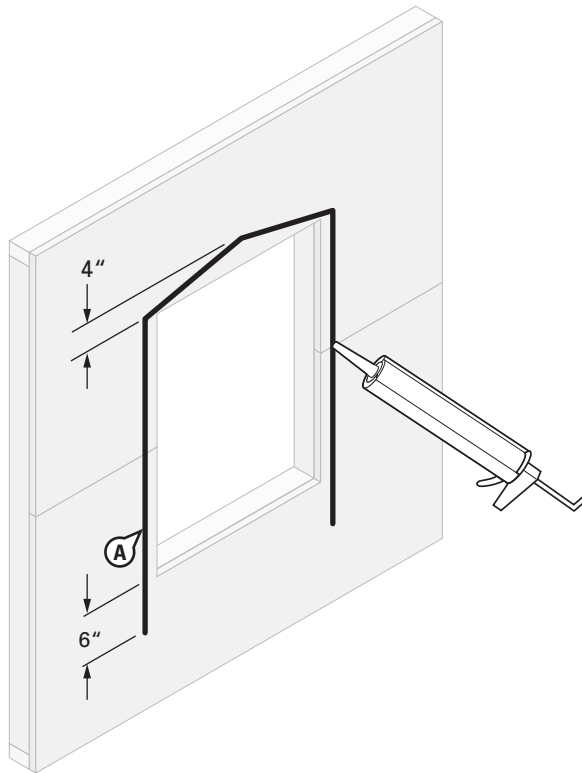

#### STEP 1

- A. Apply a continuous bead of Tower® Residential Sealant, or recommended sealant, around jambs and head, and angle the sealant to create a 4" peak. Sealant applied along each jamb should extend below sill by a maximum of 6".

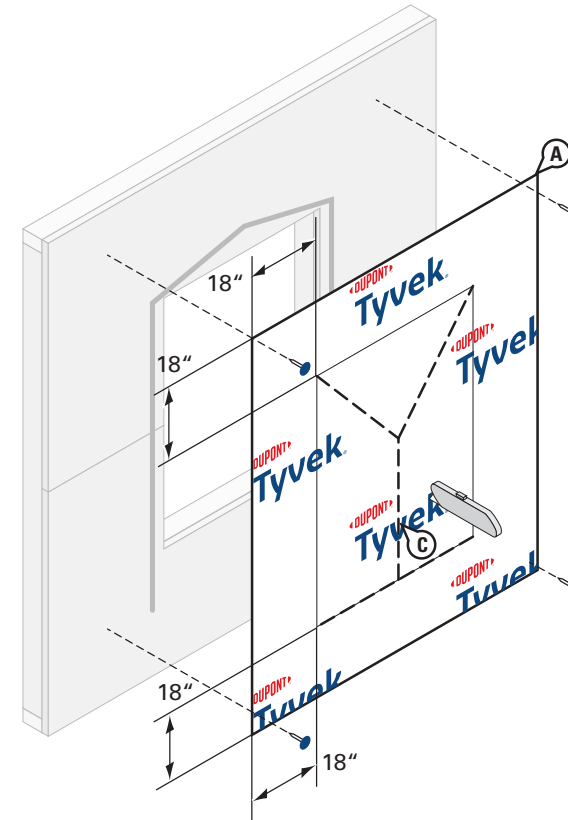

#### STEP 2

- A. Cut a piece of Tyvek® WRB that is 36" wider and 36" taller than the window rough opening to allow an 18" width around all sides.
- B. Center the piece of Tyvek® WRB over the rough opening and press into the sealant. Fasten along the sides and across the top using DuPont™ Tyvek® Wrap Caps or recommended fastening system. Fasteners should not be installed within 10" of the edge of the rough opening, and no fasteners should be installed within 12" of the bottom edge of the Tyvek® WRB. Avoid placing fasteners where DuPont Self-Adhered Flashing Products will be installed.
- C. Cut opening as shown.

## Installation Methods for DuPont Self-Adhered Flashing Products Installed BEFORE the DuPont™ Tyvek® WRB Integral Flanged Window – “Pre-Strip” Methods

### Method 1 – Rough Opening Treatment With Single Piece of Tyvek® WRB

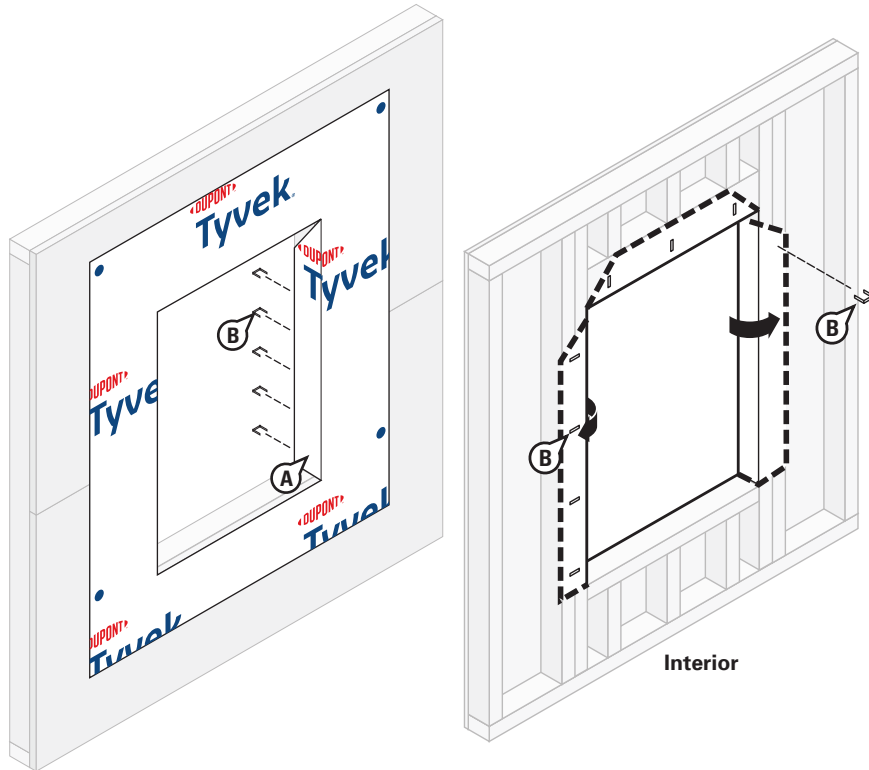

#### STEP 3

- A. Fold head and jamb flaps into rough opening.
- B. Secure flaps to inside wall framing using staples. Cut off excess flaps if desired.

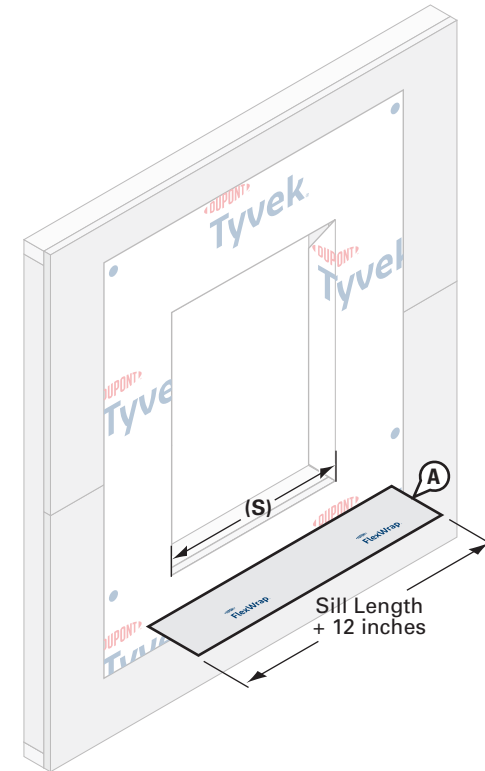

#### STEP 4

- A. Cut DuPont™ FlexWrap™ at least 12" **LONGER** than width of rough opening sill (S). Use roll widths sufficient to achieve a minimum of 1" adhesion **BEYOND** where the window frame will be located, ensuring 2"– 3" adhesion onto the face of the wall. Remove wide piece of release paper.



# Installation Methods for DuPont Self-Adhered Flashing Products Installed BEFORE the DuPont™ Tyvek® WRB Integral Flanged Window – “Pre-Strip” Methods

## Method 1 – Rough Opening Treatment With Single Piece of Tyvek® WRB

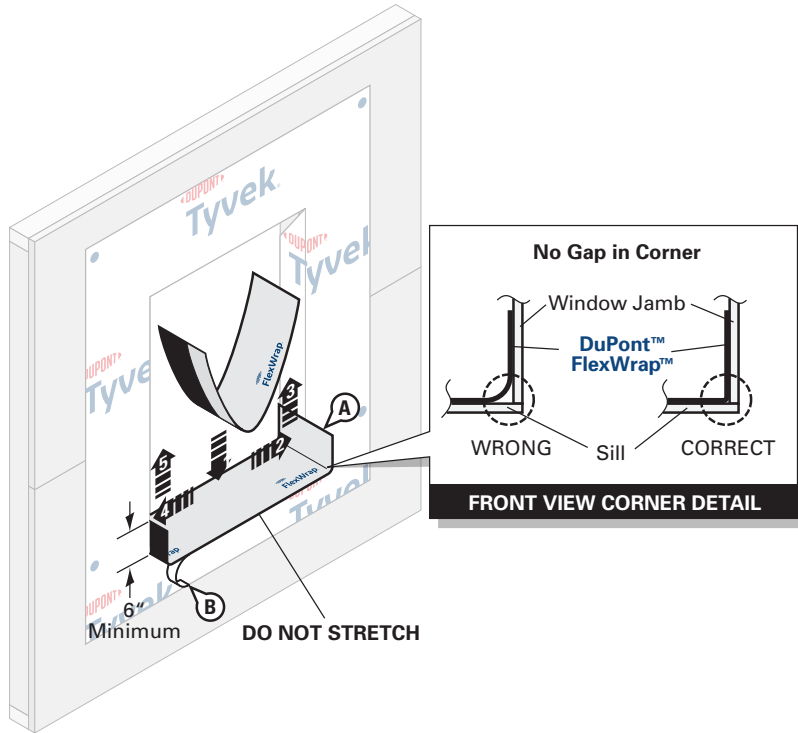

### STEP 5

- Position on horizontal sill by aligning the inside edge of the narrow release paper with the face of the wall to ensure 2”– 3” of the **DuPont™ FlexWrap™** will be adhered to the face of the wall with a minimum of 6” up each jamb. Adhere into rough opening.
- Remove narrow release paper.

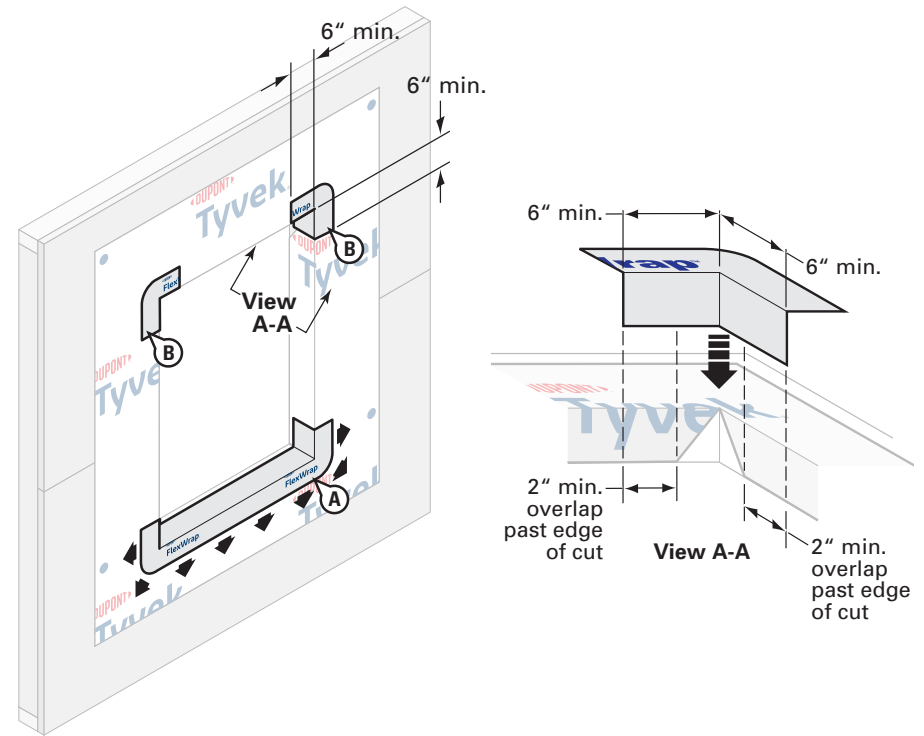

### STEP 6

- Fan out the **FlexWrap™** at corners and adhere onto face of wall. Continue adhering onto face of wall along sill.
- Install a minimum of 12” length of **FlexWrap™** at each corner of the head to extend a minimum of 6” down the jamb and at least 6” on the head as shown.

**NOTE:** A longer piece of **FlexWrap™** may be required to properly cover the exposed areas of the opening to establish a 2” minimum overlap past edge of cut. See detail View A-A.

# Installation Methods for DuPont Self-Adhered Flashing Products Installed BEFORE the DuPont™ Tyvek® WRB Integral Flanged Window – “Pre-Strip” Methods

## Method 1 – Rough Opening Treatment With Single Piece of Tyvek® WRB

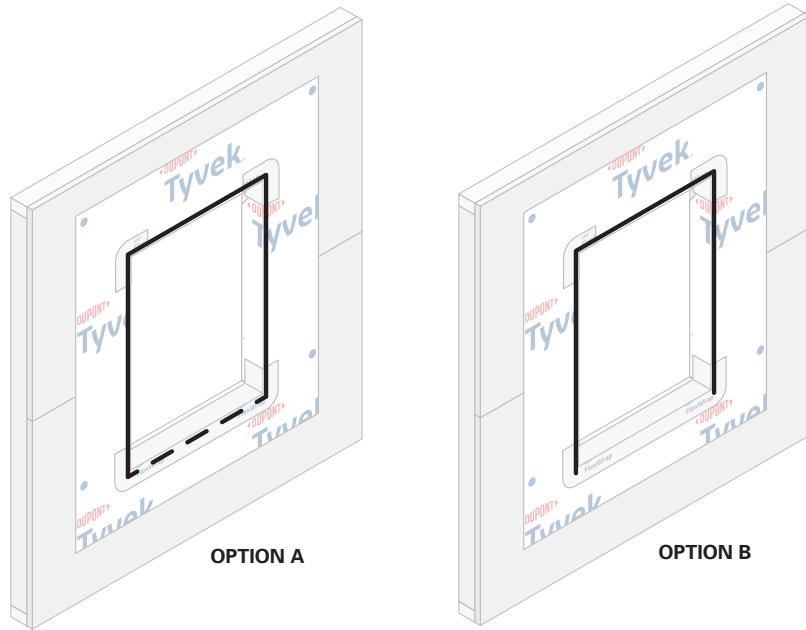

OPTION A

OPTION B

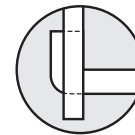
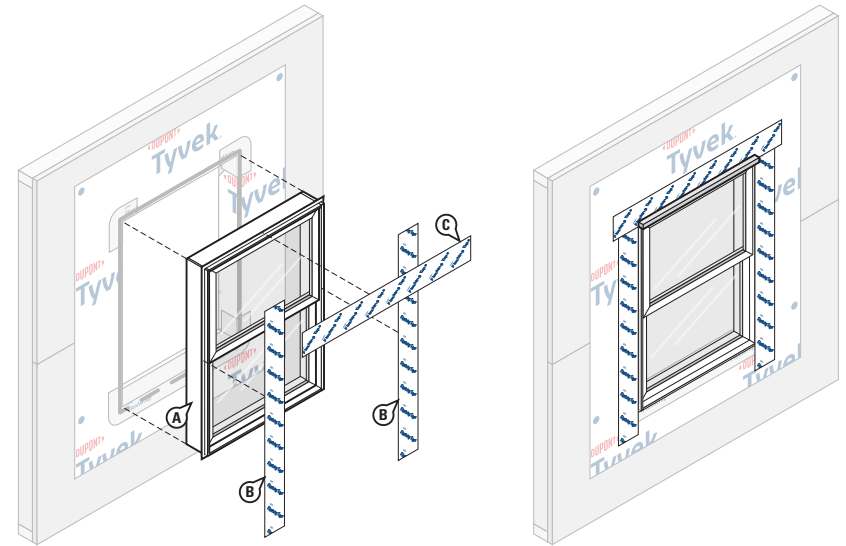

**INCORRECT**  
DuPont™ FlexWrap™  
reverse flashed

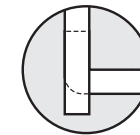

**INCORRECT**  
DuPont™ Flashing Tape  
flush with FlexWrap™

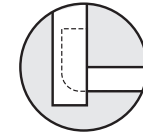

**CORRECT**  
DuPont™ Flashing Tape  
overlaps FlexWrap™

### STEP 7

**OPTION A:** Apply continuous bead of Tower® Residential Sealant, or recommended sealant, at window head and jambs to wall or back side of window mounting flange. **To allow for drainage, do not apply continuous sealant bead along sill.** Ensure a minimum 2" wide drainage gap in the sealant bead within 4" from **each corner** of the jamb-sill interface. Continue applying sealant along the sill with additional 2" wide (min.) drainage gaps for every 6"– 12" (on center) of sill width.

**OPTION B:** Apply continuous bead of Tower® Residential Sealant, or recommended sealant, at window head and jambs to wall or back side of window mounting flange. **To allow for drainage, do not apply sealant bead along sill.**

### STEP 8

- A. Install window according to manufacturer's instructions.
- B. Cut two pieces of **DuPont™ Flashing Tape** or **DuPont™ StraightFlash™** for jamb flashing extending 1" above window head flange and below bottom edge of sill flashing. Remove release paper and press tightly along sides of window frame. **Ensure proper shingling. DuPont™ Flashing Tape** or **StraightFlash™** must overlap **DuPont™ FlexWrap™** and adhere to the piece of **Tyvek® WRB**. **OPTIONAL:** If installing a drip cap as part of the window installation before the **DuPont Self-Adhered Flashing** membrane at the window head flange, see *Drip Cap Installation* section and refer to [Option 1](#). **NOTE:** The vertical leg of the drip cap must not be taller than the window head flange when installing drip cap according to [Option 1](#).
- C. Cut a piece of **DuPont™ Flashing Tape** or **StraightFlash™** for head flashing, which should extend **BEYOND** the outer edges of the jamb flashings. Remove release paper and install to completely cover flange while also adhering to the face of the wall. **OPTIONAL:** If installing a drip cap as part of the window installation, but after the window head flashing, see *Drip Cap Installation* section and refer to [Option 2](#).

## Installation Methods for DuPont Self-Adhered Flashing Products Installed BEFORE the DuPont™ Tyvek® WRB Integral Flanged Window – “Pre-Strip” Methods

### Method 1 – Rough Opening Treatment With Single Piece of Tyvek® WRB

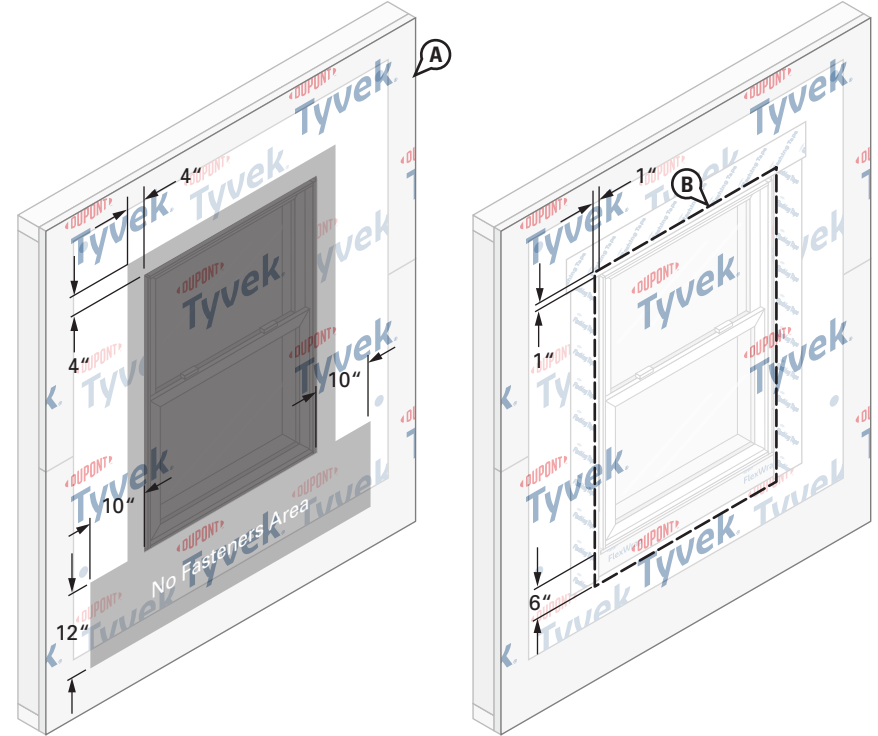
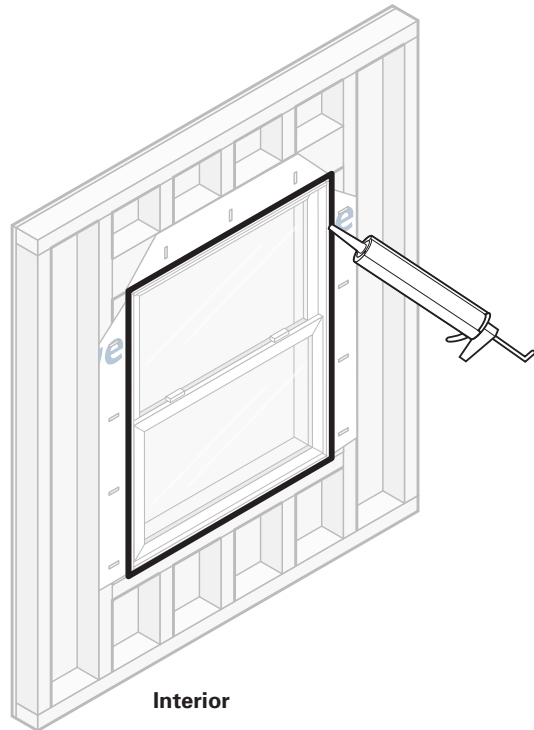

#### STEP 9

Install Tower® Residential Sealant or recommended sealant (and backer rod as necessary) around the window opening at the interior. It is also acceptable to use **Great Stuff Pro™ Window & Door Polyurethane Foam Sealant**, or recommended foam. When using Tower® Residential Sealant, tool sealant bead flat to allow the natural curing process to create a concave shape. Be sure that the sealant penetrates the grooves of the **DuPont™ FlexWrap™** around the sill. When using **Great Stuff Pro™ Window & Door Polyurethane Foam Sealant** in perimeter openings less than 1/2", apply using the plastic extension tip for the **Great Stuff Pro™ Dispensing Gun** during installation.

#### STEP 10

- Install the **Tyvek® WRB** as shown in the [DuPont™ Tyvek® WRB Installation Instructions](#) section of this document. Do not install fasteners within 4" of the window frame at jambs and head and within 18" of the window frame at sill or location of **Tyvek® WRB** piece below sill of window.
- Mark a perimeter on the **Tyvek® WRB** around the rough opening a minimum of 1" from the jambs and head of the window frame, and 6" below the sill of the window frame.

## Installation Methods for DuPont Self-Adhered Flashing Products Installed BEFORE the DuPont™ Tyvek® WRB Integral Flanged Window – “Pre-Strip” Methods

### Method 1 – Rough Opening Treatment With Single Piece of Tyvek® WRB

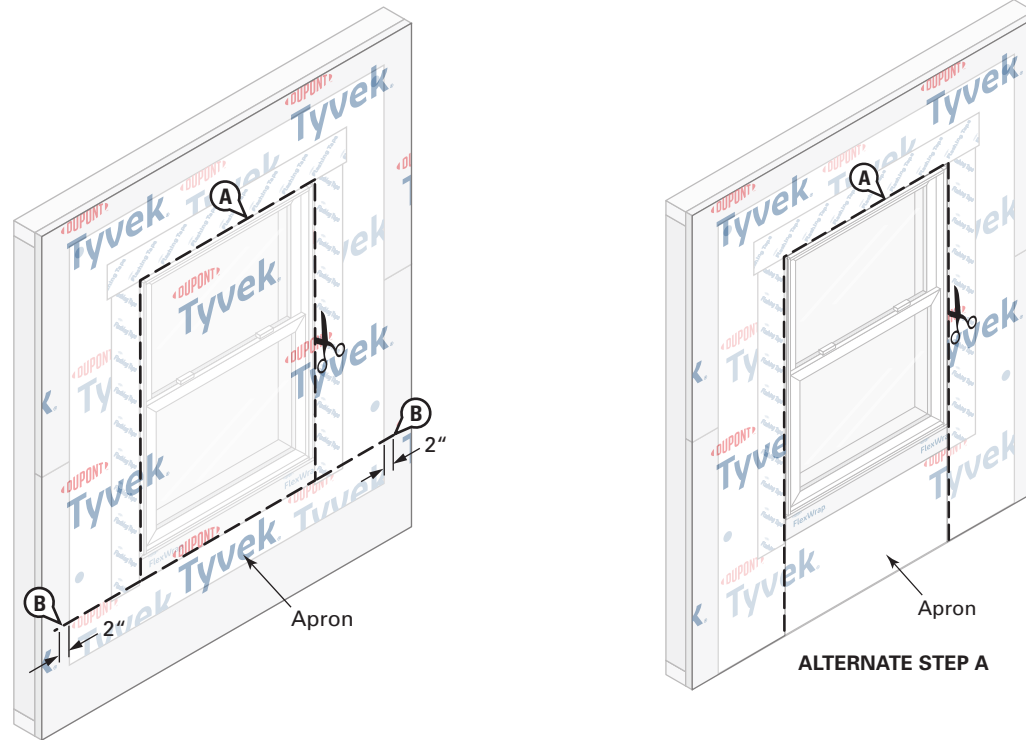

## STEP 11

- A. Cut the **Tyvek® WRB** along perimeter marking to expose window. Do not cut through the **DuPont Self-Adhered Flashing Products** or the piece of **Tyvek® WRB** underneath.
- B. Create horizontal slits in the **Tyvek® WRB** at each lower corner of the perimeter cut that extend 1”– 2” **BEYOND** the piece of **Tyvek® WRB** underneath.

**ALTERNATE STEP A:** If piece of **Tyvek® WRB** extends far enough below the sill rough opening to overlap the sill plate, base of wall flashing, or the **Tyvek® WRB** below, the **Tyvek® WRB** can be cut along jambs and head only to overlap the piece of **Tyvek® WRB** underneath.

## Installation Methods for DuPont Self-Adhered Flashing Products Installed BEFORE the DuPont™ Tyvek® WRB Integral Flanged Window – “Pre-Strip” Methods

### Method 1 – Rough Opening Treatment With Single Piece of Tyvek® WRB

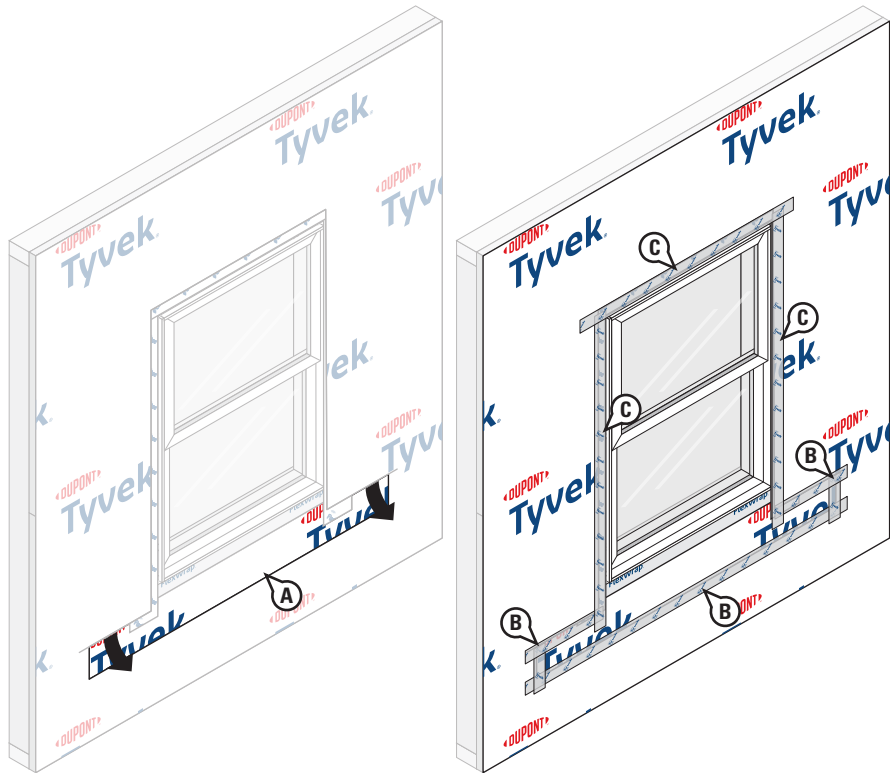

## STEP 12

### Final Step

- A. Bring the bottom portion of the piece of **Tyvek® WRB** underneath through the sill perimeter cut and horizontal slits so it laps over the top layer of **Tyvek® WRB**.
- B. Working from bottom to top, install **DuPont™ Tyvek® Tape** to secure horizontal and vertical seams of the **Tyvek® WRB** piece below sill.
- C. Install **Tyvek® Tape** along jambs and head to seal **Tyvek® WRB** around window. For a more robust termination, **DuPont™ Flashing Tape** or **DuPont™ StraightFlash™** can be used. **OPTIONAL:** If installing a drip cap **AFTER** the **Tyvek® WRB** is installed and sealed, see *Drip Cap Installation* section and refer to [Option 3](#).

## Installation Methods for DuPont Self-Adhered Flashing Products Installed BEFORE the DuPont™ Tyvek® WRB

### Integral Flanged Window – “Pre-Strip” Methods

Alternate Installation For Rough Opening Air Barrier Continuity and Head Drainage Detail

This method applies to the following products: DuPont™ Flashing Tape, DuPont™ FlexWrap™, and DuPont™ StraightFlash™

#### Method 2 – Rough Opening Treatment Using Strips of Tyvek® WRB

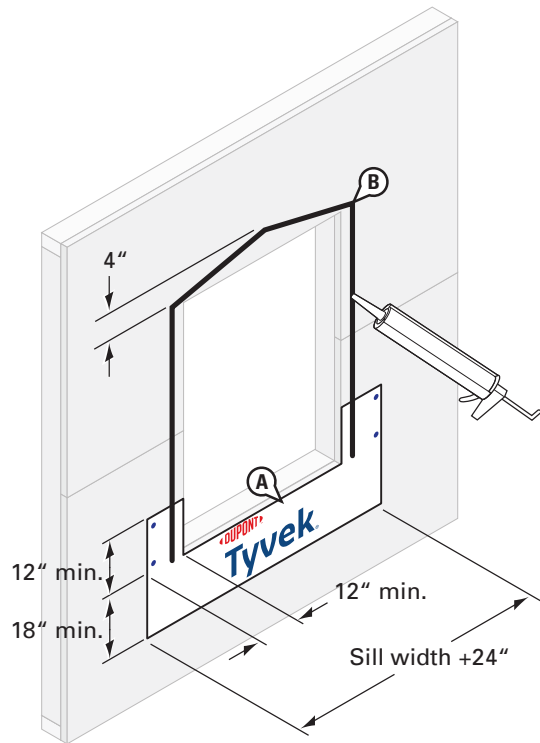

#### STEP 1

- Cut an apron made of **Tyvek® WRB** for attachment at sill of rough opening. Apron should extend at least 12" up sides and 12" **BEYOND** the sides of rough opening jambs and at least 18" below sill of rough opening, or extend far enough below the sill rough opening to overlap the sill plate, base of wall flashing, or the **Tyvek® WRB** below. Fasten along the sides and across the top using **DuPont™ Tyvek® Wrap Caps** or recommended fastening system. Fasteners should not be installed within 10" of the edge of the rough opening, and no fasteners should be installed within 6" of the bottom edge of the **Tyvek® WRB**. Avoid placing fasteners where **DuPont Self-Adhered Flashing Products** will be installed.
- Install continuous bead of Tower® Residential Sealant, or recommended sealant, around jambs and head. Angle the sealant to create a 4" peak.

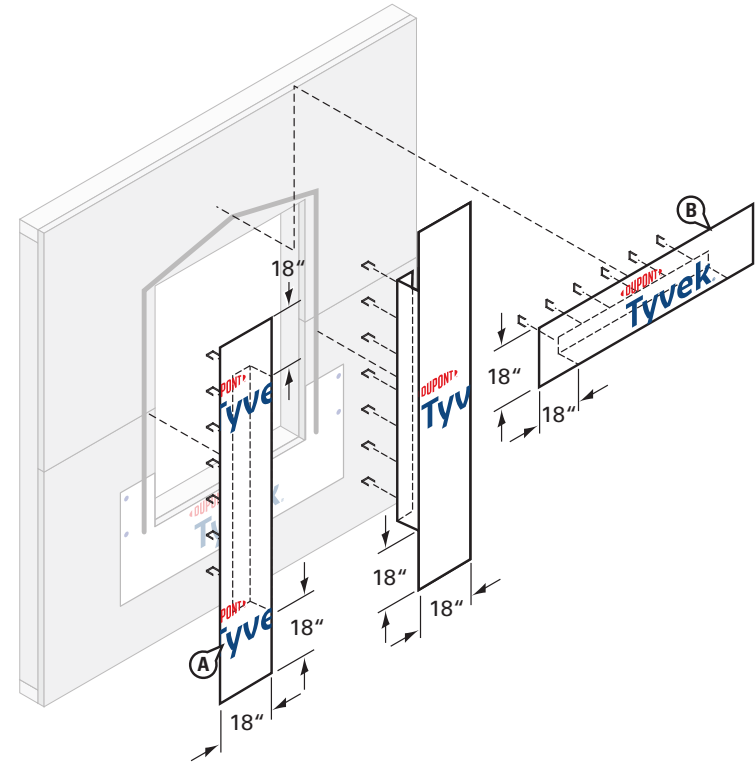

#### STEP 2

- Cut 2 pieces of **Tyvek® WRB** for jambs long enough to extend 18" above and below rough opening, and wide enough to extend 18" onto face of wall and wrap into rough opening and onto interior framing. Trim each piece to create flaps as shown. Press the pieces of **Tyvek® WRB** into the sealant and wrap in and around the studs at the jambs. Staple to inside framing to secure.
- Cut 1 piece of **Tyvek® WRB** for head long enough to extend 18" **BEYOND** the sides of rough opening, and wide enough to extend 18" onto face of wall and wrap into rough opening and onto interior framing. Trim each piece to create flap as shown. Press the piece of **Tyvek® WRB** into the sealant and wrap in and around the studs at the head. Staple to inside framing to secure.

## Installation Methods for DuPont Self-Adhered Flashing Products Installed BEFORE the DuPont™ Tyvek® WRB Integral Flanged Window – “Pre-Strip” Methods

### Method 2 – Rough Opening Treatment Using Strips of Tyvek® WRB

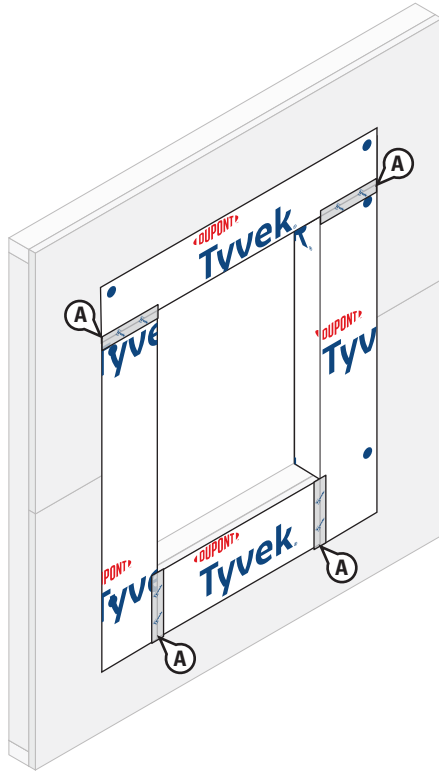

#### STEP 3

A. Seal the vertical and horizontal Tyvek® WRB seams using DuPont™ Tyvek® Tape.

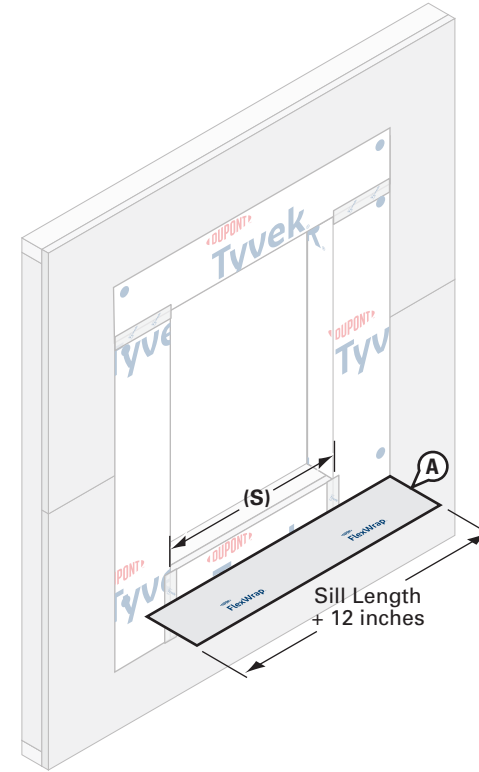

#### STEP 4

A. Cut DuPont™ FlexWrap™ at least 12" **LONGER** than width of rough opening sill (S). Use roll widths sufficient to achieve a minimum of 1" adhesion **BEYOND** where the window frame will be located, ensuring 2"– 3" adhesion onto the face of the wall. Remove wide piece of release paper.

# Installation Methods for DuPont Self-Adhered Flashing Products Installed BEFORE the DuPont™ Tyvek® WRB Integral Flanged Window – “Pre-Strip” Methods

## Method 2 – Rough Opening Treatment Using Strips of Tyvek® WRB

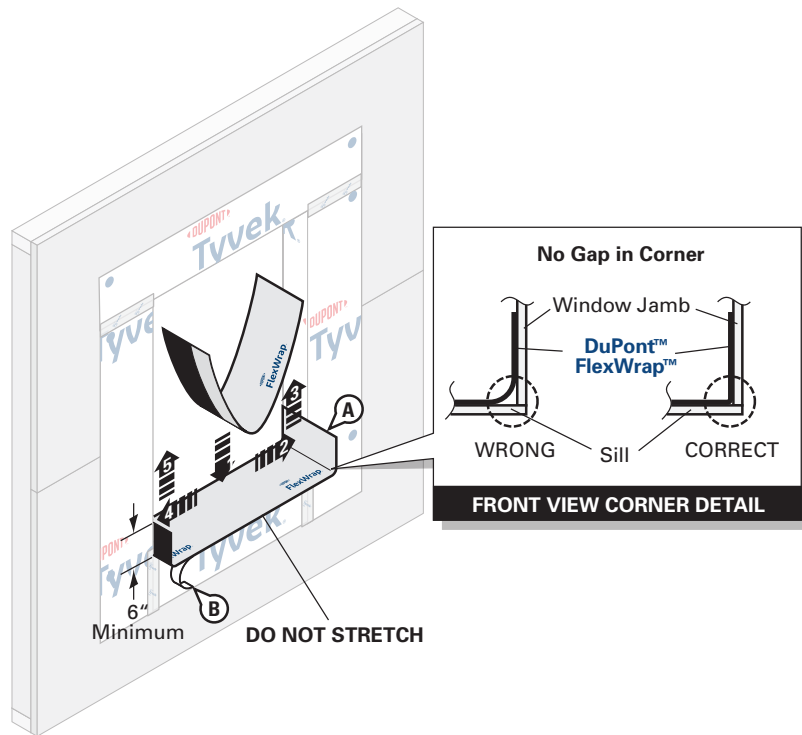

### STEP 5

- A. Position on horizontal sill by aligning the inside edge of the narrow release paper with the face of the wall to ensure 2”– 3” of the **DuPont™ FlexWrap™** will be adhered to the face of the wall with a minimum of 6” up each jamb. Adhere into rough opening.
- B. Remove narrow release paper.

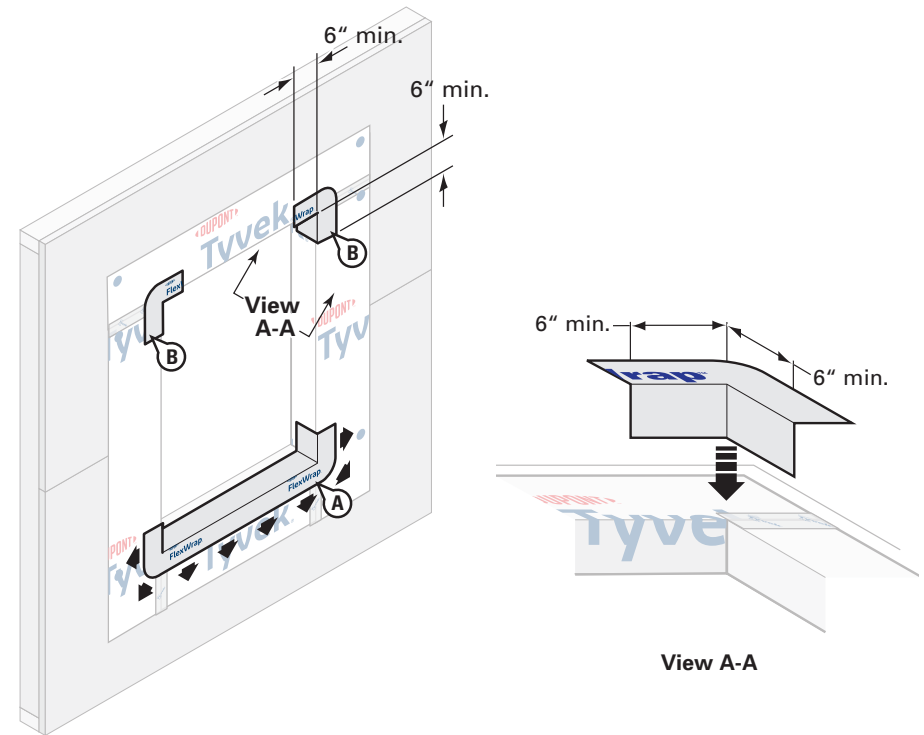

### STEP 6

- A. Fan out **FlexWrap™** at corners and adhere onto face of wall. Continue adhering onto face of wall along sill.
- B. Install a minimum of 12” length of **FlexWrap™** at each corner of the head to extend a minimum of 6” down the jamb and at least 6” on the head as shown.



## Installation Methods for DuPont Self-Adhered Flashing Products Installed BEFORE the DuPont™ Tyvek® WRB Integral Flanged Window – “Pre-Strip” Methods

### Method 2 – Rough Opening Treatment Using Strips of Tyvek® WRB

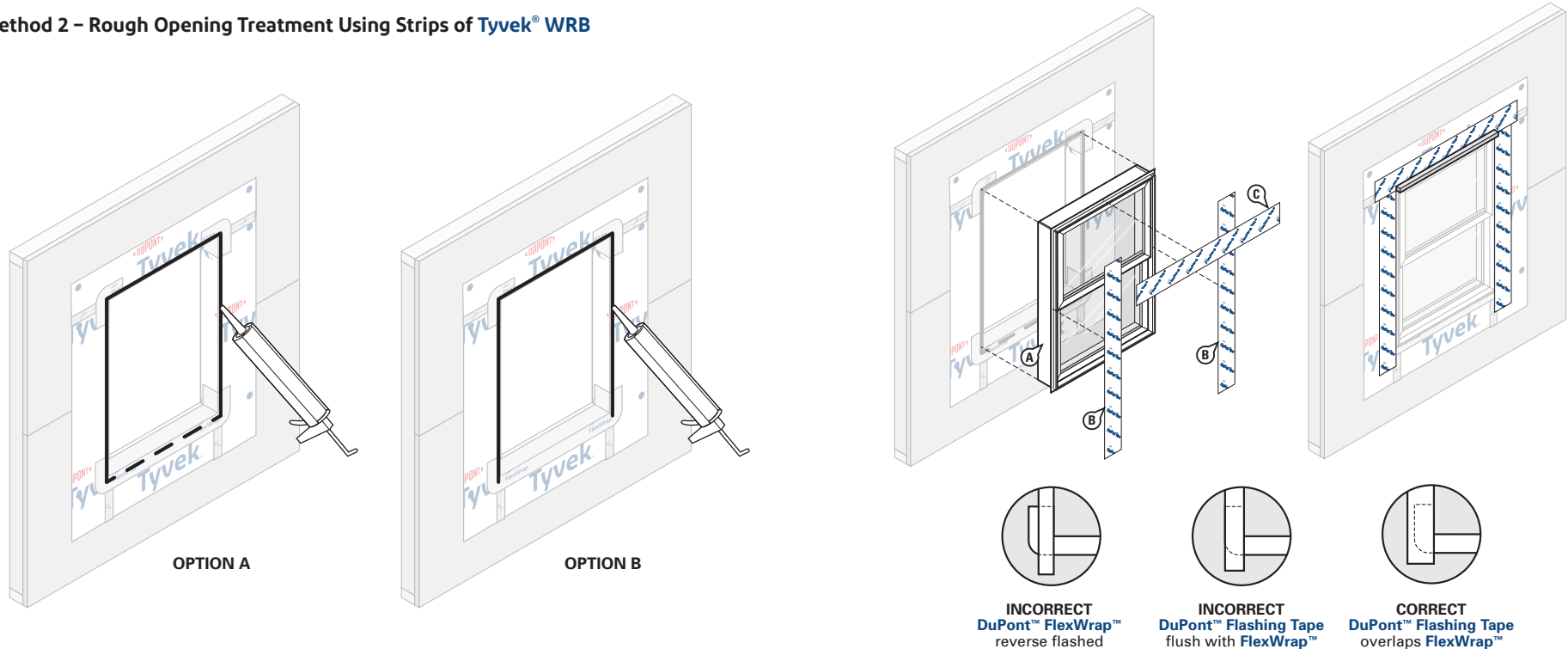

#### STEP 7

**OPTION A:** Apply continuous bead of Tower® Residential Sealant, or recommended sealant, at window head and jambs to wall or back side of window mounting flange. **To allow for drainage, do not apply continuous sealant bead along sill.** Ensure a minimum 2" wide drainage gap in the sealant bead within 4" from **each corner** of the jamb-sill interface. Continue applying sealant along the sill with additional 2" wide (min.) drainage gaps for every 6"– 12" (on center) of sill width.

**OPTION B:** Apply continuous bead of Tower® Residential Sealant, or recommended sealant, at window head and jambs to wall or back side of window mounting flange. **To allow for drainage, do not apply sealant bead along sill.**

#### STEP 8

- Install window according to manufacturer's instructions.
- Cut two pieces of **DuPont™ Flashing Tape** or **DuPont™ StraightFlash™** for jamb flashing extending 1" above window head flange and below bottom edge of sill flashing. Remove release paper and press tightly along sides of window frame. Ensure proper shingling. **DuPont™ Flashing Tape** or **StraightFlash™** must overlap **DuPont™ FlexWrap™** and adhere to the piece of **Tyvek® WRB**. **OPTIONAL:** If installing a drip cap as part of the window installation before the **DuPont Self-Adhered Flashing** membrane at the window head flange, see *Drip Cap Installation* section and refer to [Option 1](#). **NOTE:** The vertical leg of the drip cap must not be taller than the window head flange when installing drip cap according to [Option 1](#).
- Cut a piece of **DuPont™ Flashing Tape** or **StraightFlash™** for head flashing long enough to extend **BEYOND** the outer edges of jamb flashings. Remove release paper and install completely covering mounting flange and adhering to the **Tyvek® WRB** pieces.

**OPTIONAL:** If installing a drip cap as part of the window installation, but after the window head flashing, see *Drip Cap Installation* section and refer to [Option 2](#).

## Installation Methods for DuPont Self-Adhered Flashing Products Installed BEFORE the DuPont™ Tyvek® WRB Integral Flanged Window – “Pre-Strip” Methods

### Method 2 – Rough Opening Treatment Using Strips of Tyvek® WRB

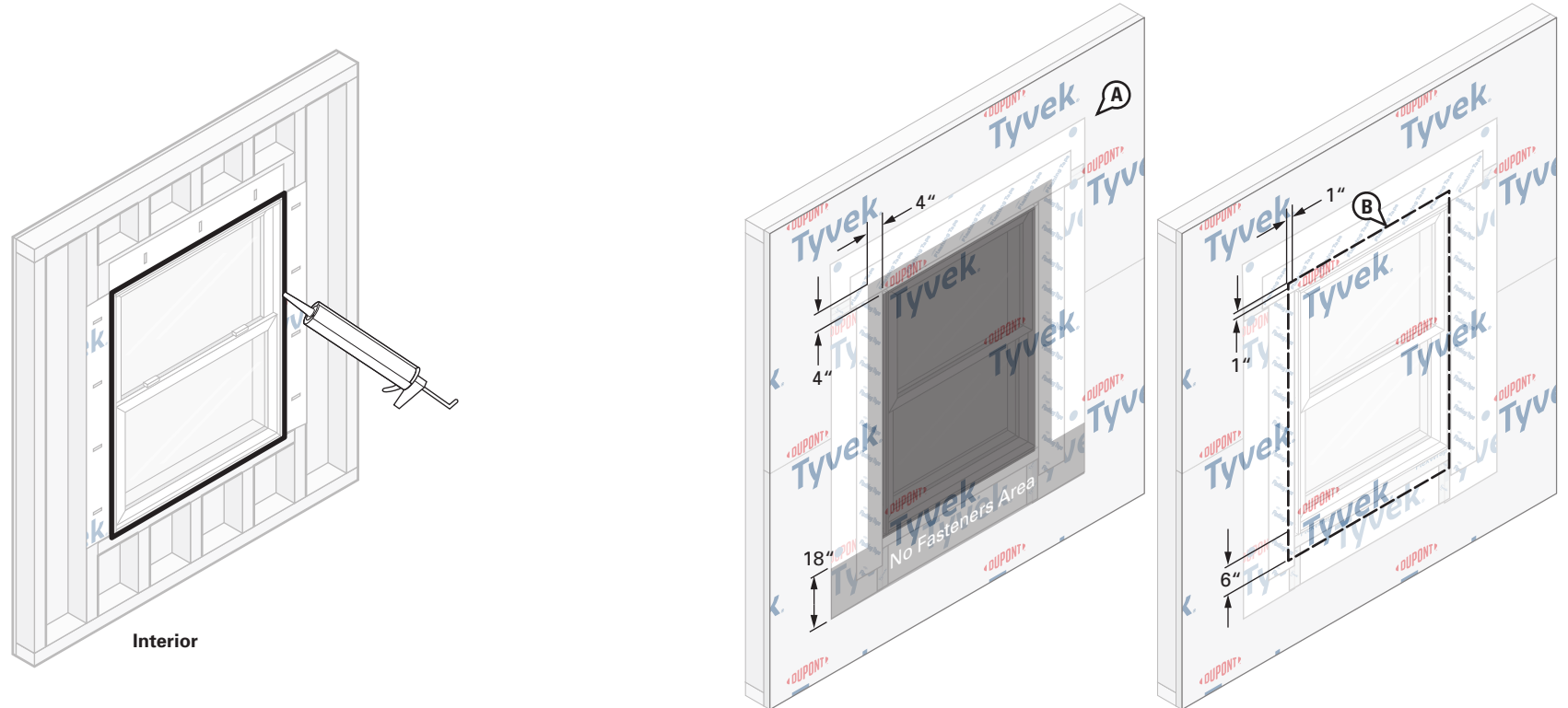

#### STEP 9

Install Tower® Residential Sealant or recommended sealant (and backer rod as necessary) around the window opening at the interior. It is also acceptable to use **Great Stuff Pro™ Window & Door Polyurethane Foam Sealant**, or recommended foam. When using Tower® Residential Sealant, tool sealant bead flat to allow the natural curing process to create a concave shape. Be sure that the sealant penetrates the grooves of the **DuPont™ FlexWrap™** around the sill. When using **Great Stuff Pro™ Window & Door Polyurethane Foam Sealant** in perimeter openings less than 1/2", apply using the plastic extension tip for the **Great Stuff Pro™ Dispensing Gun** during installation.

#### STEP 10

- Install the **Tyvek® WRB** as shown in the [DuPont™ Tyvek® WRB Installation Instructions](#) section of this document. Do not install fasteners within 4" of the window frame at jambs and head and within 18" of the window frame at sill or location of **Tyvek® WRB** piece below sill of window.
- Mark a perimeter on the **Tyvek® WRB** around the rough opening a minimum of 1" from the jambs and head of the window frame, and 6" below the sill of the window frame.

## Installation Methods for DuPont Self-Adhered Flashing Products Installed BEFORE the DuPont™ Tyvek® WRB Integral Flanged Window – “Pre-Strip” Methods

### Method 2 – Rough Opening Treatment Using Strips of Tyvek® WRB

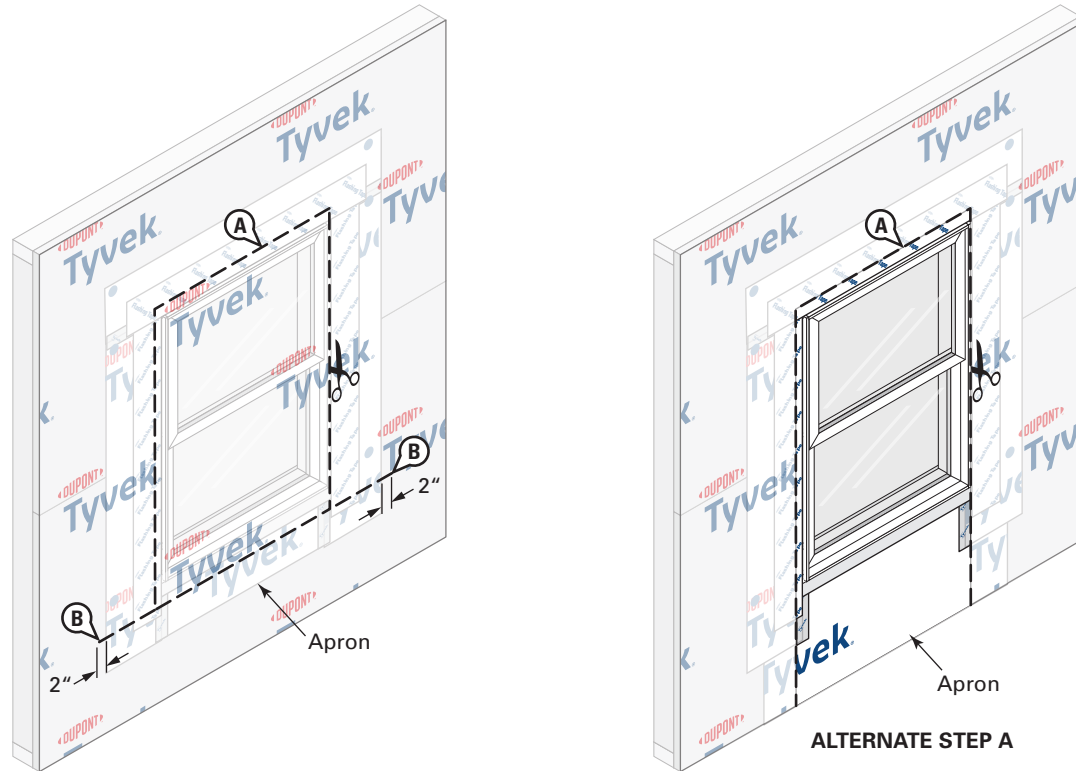

#### STEP 11

- A. Cut the **Tyvek® WRB** along perimeter marking to expose window. Do not cut through the **DuPont Self-Adhered Flashing Products** or **Tyvek® WRB** apron underneath.
- B. Create horizontal slits in the **Tyvek® WRB** at each lower corner of the perimeter cut that extend 1”– 2” **BEYOND** the pieces of **Tyvek® WRB** underneath.

**ALTERNATE STEP A:** If pieces of **Tyvek® WRB** extend far enough below the sill rough opening to overlap the sill plate, base of wall flashing, or the **Tyvek® WRB** below, the **Tyvek® WRB** can be cut along jambs and head only to overlap pieces of **Tyvek® WRB** underneath.

## Installation Methods for DuPont Self-Adhered Flashing Products Installed BEFORE the DuPont™ Tyvek® WRB Integral Flanged Window – “Pre-Strip” Methods

### Method 2 – Rough Opening Treatment Using Strips of Tyvek® WRB

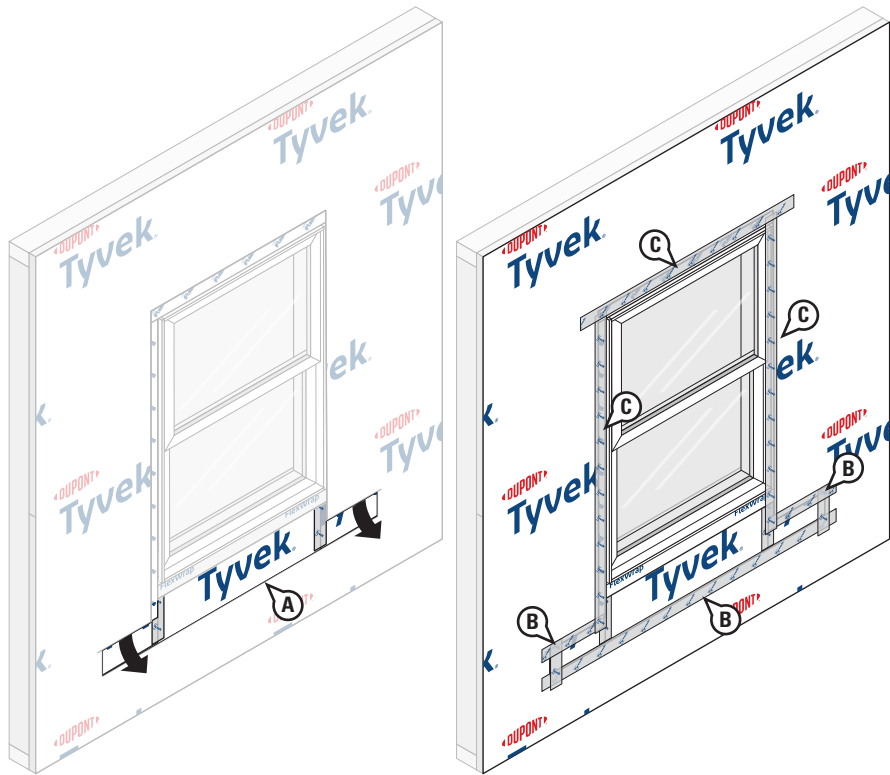

## STEP 12

### Final Step

- A. Bring the bottom portion of the pieces of **Tyvek® WRB** through the sill perimeter cut and horizontal slits to lap over the top layer of **Tyvek® WRB**.
- B. Working from bottom to top, install **DuPont™ Tyvek® Tape** to secure horizontal and vertical seams of the **Tyvek® WRB** pieces below sill.
- C. Install **Tyvek® Tape** along jambs and head to seal **Tyvek® WRB** around window. For a more robust termination, **DuPont™ Flashing Tape** or **DuPont™ StraightFlash™** can be used. **OPTIONAL:** If installing a drip cap **AFTER** the **Tyvek® WRB** is installed and sealed, see *Drip Cap Installation* section and refer to [Option 3](#)

# DuPont™ Tyvek® WRB Installation Instructions (Windows/Doors Installed BEFORE the Tyvek® WRB)

## Key Installation Requirements for DuPont™ Tyvek® WRBs

### Continuity

It is important to maintain the continuity of the **Tyvek® WRB** throughout the building envelope. The entire wall surface shall be wrapped, including unconditioned spaces. Special attention should be given to ensure a proper 6" overlap at all terminations, seams, penetrations, and transitions to maintain a continuous downward drainage plane and WRB. Installing the **Tyvek® WRB** as an air barrier is the preferred installation method. However, skip-taping terminations and untaped horizontal seams is allowed when the **Tyvek® WRB** is being installed as a water-resistive barrier only. All vertical seams must be taped for both air barrier and water-resistive barrier installations.

An airtight home prevents cold air infiltration in the winter months, and moist warm air infiltration in the summer months. **Tyvek® WRBs** can be used to create an air barrier that contributes to overall air tightness and energy efficiency by helping keep conditioned air inside of the home, minimizing energy loss.

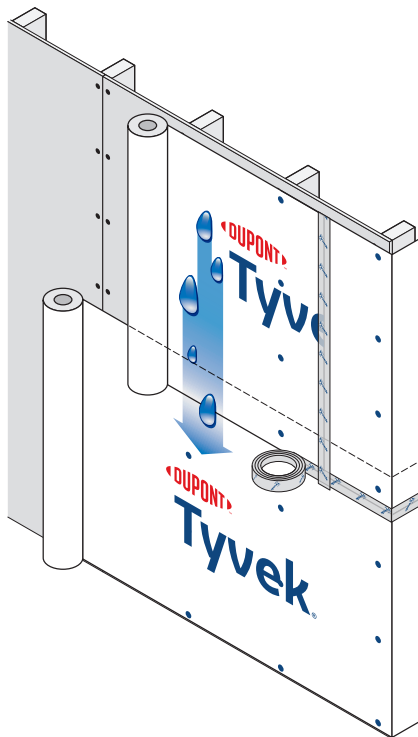

### Penetrations

Seal **Tyvek® WRBs** around all penetrations (electrical, HVAC and plumbing, etc.) with the appropriate **DuPont™ Flashing Systems product**. Products that have flanges should be integrated into the **Tyvek® WRB**. The penetration rough opening can be sealed from the interior side using Tower® Residential Sealant, recommended sealant (and backer rod as necessary), or **Great Stuff Pro™ Window & Door Polyurethane Foam Sealant, Great Stuff Pro™ Gaps & Cracks Polyurethane Foam Sealant**, or recommended foam.

### Overlap

Ensure proper shingling with a 6" minimum overlap of weather-resistive barrier components from the bottom to the top of the wall to help facilitate proper drainage.

### Sealants and Adhesives/Primers

Review the manufacturers' literature or label to confirm that the product(s) used have the chemical and adhesive properties necessary for use with **Tyvek® WRBs, DuPont Self-Adhered Flashing Products, and DuPont™ Tyvek® Fluid Applied Products**. Refer to [Chemical Compatibility of Representative Building Sealants and Adhesives/Primers](#) for more information about chemical compatibility.

### Fasteners

Use **DuPont™ Tyvek® Wrap Cap Fasteners**, TRUFAST® Walls<sup>1</sup> Grip-Deck® screws with Thermal-Grip FastCap™ washers, or recommended alternates, per the fastening schedule included in this installation guideline. Temporary fasteners should not be relied upon to permanently attach **Tyvek® WRBs**, due to the limited holding power of these fastening methods. If temporary fasteners are used, permanent fastening (cladding fasteners) must be applied as soon as practically possible in order to maintain the integrity and performance of the **Tyvek® WRB** and to be in compliance with DuPont Installation Guidelines if making a claim under the DuPont Product and Labor component of the DuPont Building Envelope Solutions Products 10-Year Limited Warranty.

<sup>1</sup>TRUFAST® Walls formerly Rodenhouse

<sup>2</sup>Except when installing Tyvek® WRB over foam and other non-nail-base sheathings.

<sup>3</sup>For more information about the Grip-Lok® Autofeed Fastening System, refer to manufacturer's instructions and contact your local DuPont™ Tyvek® Specialist.

### Recommended Fasteners

For increased holding power and for higher air and water holdout performance, DuPont recommends fasteners of sufficient length to penetrate securely into the stud. Secure **Tyvek® WRB** to the stud or other nail-base material, i.e., wood sheathing. Cap nail and/or cap staple fasteners should be placed no closer than 6" and no farther than 18" on vertical stud lines. Securing along stud lines will assist in maintaining fastening pattern. Penetrating bandboard or other horizontal members may be necessary to maintain fastening pattern. Do not install fasteners within 6" of the sills and jams and within 9" of the head of the window rough openings. Use one or more of the recommended fasteners below for use with **Tyvek® WRBs**:

- **DuPont™ Tyvek® Wrap Cap Staples** or other cap staples for Stinger® Cap Stapler<sup>2</sup>
- **DuPont™ Tyvek® Wrap Cap Nails**
- **2" DuPont™ Tyvek® Wrap Cap Screws** (for steel frame construction, may also be used for wood frame)
- TRUFAST® Walls Grip-Deck® screws with Thermal-Grip FastCap™ washers installed at 16" vertical spacing along stud lines for 16" o.c. framing (approved for use with **Tyvek® WRBs**). Install fasteners with standard hand drill or Grip-Lok® Autofeed Fastening System<sup>3</sup> with modified nose adaptor.

### Wood frame construction:

- 1-5/8" – 6" TRUFAST® Walls Grip-Deck® HiLo Thread Screws with 2" Thermal-Grip FastCap™ washer
- 1-5/8", 2", 2-1/2", and 3" screws can be installed with standard hand drill or Grip-Lok® Autofeed Fastening System with modified nose adapter
- 3-1/2" to 6" screws should be installed with standard hand drill.
- Other manufacturers' equivalent fasteners.

## DuPont™ Tyvek® WRB Installation Instructions (Windows/Doors Installed BEFORE the Tyvek® WRB)

### Temporary Fastening

Selection and use of temporary fastening methods is an option dependent on building schedule, cladding options, and local building practices. Temporary fasteners should not be relied upon to permanently attach **Tyvek® WRBs** due to the limited holding power of these fastening methods. If temporary fasteners are used, permanent fastening should be applied as soon as practically possible in order to maintain the integrity and performance of the **Tyvek® WRB**. Permanent fasteners include cladding fasteners such as brick ties, lath fasteners for traditional stucco, exterior foam board fasteners, or siding installed with nails. Cladding shall be installed according to applicable building codes and industry standards.

Temporary fastening methods:

- DuPont fasteners or equivalent alternate fasteners at a reduced schedule of 24" to 48".
- A recommended adhesive applied in vertical strips at 24" to 36" spacing or along every other stud line. Vertical strips may be applied to the outer face of the sheathing or directly to the studs for open stud construction. When using adhesives, care must be taken to avoid excessive surface coverage as this may impact the vapor permeability of the **Tyvek® WRB** in that area. Refer to [Chemical Compatibility of Representative Building Sealants and Adhesives/Primers](#) for more information about recommended adhesives.
- If staples without caps are used to temporarily fasten **Tyvek® WRBs** to OSB, plywood, or exterior gypsum sheathing, the fastening schedule must not exceed 24" to 36" vertically, with fasteners at every other stud for 16" o.c. framing. 24" o.c. framing will require horizontal fastening on every stud, with 24" to 36" fastener spacing vertically. Staples should not be used with fiberboard or foam sheathing. If installing as an air barrier, each staple must be covered with **DuPont™ Tyvek® Tape**. Covering the staples underneath a taped air and water barrier seam is also acceptable if installing the **Tyvek® WRB** as an air barrier.

**NOTE:** These Temporary Fastening Methods are subject to change based on new technology or testing information and may be superseded at any time. It is always important to follow the latest guidelines which may be found on [building.dupont.com](http://building.dupont.com). For additional guidance, please consult your local DuPont™ Tyvek® Specialist.

### Alternate Fastening

- A. Standard brick tie base plates.
- B. **DuPont™ RainVent™ Battens** or wood furring strips mounted vertically. If furring strips are shimmed, **DuPont™ Flashing Tape**, **DuPont™ StraightFlash™**, or recommended alternate patches can be installed as a best practice behind furring strip fasteners.

#### Notes:

- Additional fasteners may be needed between brick ties, and other alternate fasteners to maintain recommended fastener spacing.
- **DuPont™ Flashing Tape**, **StraightFlash™**, or DuPont recommended alternate patches can be installed behind fastening plates (brick tie base plates, metal fastening clips, metal channels, etc.) for additional air and water holdout.

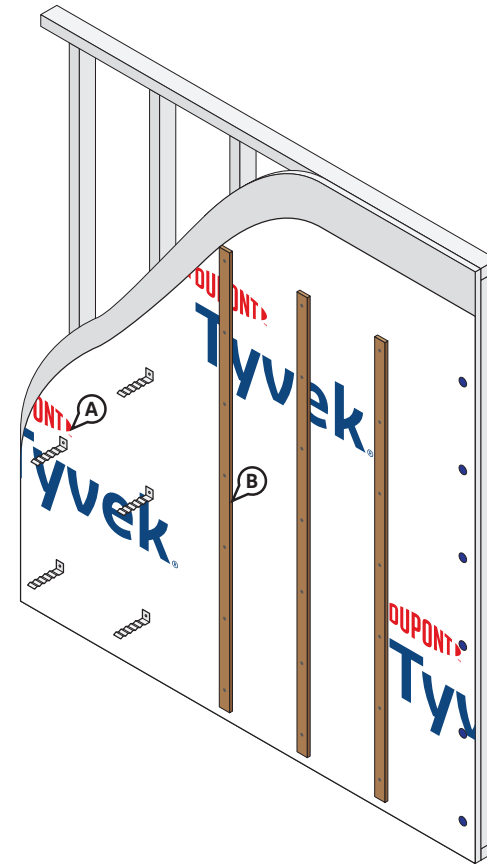

## DuPont™ Tyvek® WRB Installation Instructions (Windows/Doors Installed BEFORE the Tyvek® WRB)

### Installation Method for New Construction

Start at bottom corner of structure to ensure proper shingling throughout the installation. Proper shingling is required to shed water and to prevent water from entering the wall system. Printed stud marks are available on some Tyvek® WRBs to aid in aligning with the studs (e.g. studmarks are 8" apart for DuPont™ Tyvek® HomeWrap® and an 8" x 8" grid is printed on DuPont™ Tyvek® CommercialWrap®).

#### STEP 1

Align roll at bottom corner of structure. Roll should be plumb.

Bottom edge of roll must:

- extend over sill plate interface onto foundation by at least 1" (2" or greater is recommended)
- extend to bottom of sill plate for slab on grade foundations, or,
- be properly integrated with water drainage components such as kick out flashing or weep screed (for stucco exteriors).

When bottom edge of roll is less than 2" over the sill plate interface, it is recommended to seal or skip-seal the Tyvek® WRB at the bottom of the wall. See bottom of wall termination options on the next page.

#### STEP 2

Unwrap roll starting at corner. Unroll directly over windows and doors. Overlap all vertical seams by 6"– 12".

#### STEP 3

Secure Tyvek® WRB to the stud or other nail-base material, i.e., wood sheathing in accordance with the *Recommended Fasteners* section of [Key Installation Requirements for DuPont™ Tyvek® WRBs](#). Fasteners should be placed no closer than 6" and no farther than 18" on vertical stud lines. Securing along stud lines will assist in maintaining fastening pattern. When installing with fasteners that are longer than the thickness of the sheathing, the fasteners must be installed into the studs. Penetrating bandboard or other horizontal members may be necessary to maintain fastening pattern. **Do not install fasteners within 6" of the sills and jambs and within 9" of the head of the window rough openings.**

Use one or more of the recommended fasteners below for use with Tyvek® WRBs:

- DuPont™ Tyvek® Wrap Cap Staples or other cap staples for Stinger® Cap Stapler\*
- DuPont™ Tyvek® Wrap Cap Nails
- DuPont™ Tyvek® Wrap Cap Screws
- TRUFAST® Walls Grip-Deck® screws with Thermal-Grip FastCap™ washers (TRUFAST® Walls formerly Rodenhouse)
- Other manufacturers' equivalent cap fasteners

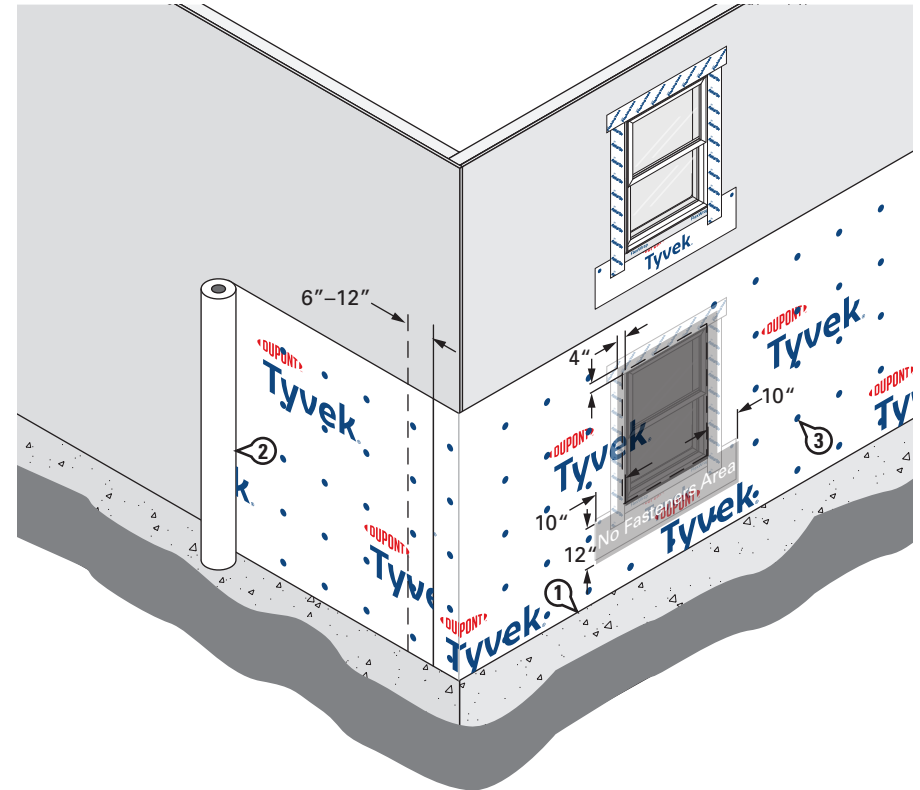

\*Except when installing Tyvek® WRB over foam and other non-nail-base sheathings.



# DuPont™ Tyvek® WRB Installation Instructions (Windows/Doors Installed BEFORE the Tyvek® WRB)

## Installation Method for New Construction

### STEP 4

Upper layer of **Tyvek® WRB** should overlap bottom layer by a minimum of 6". The **Tyvek® WRB** must be integrated with window flashing using proper shingling. Refer to the [DuPont Self-Adhered Flashing Products Integration](#) section for more information. If non-self-adhering sill flashing is used, install the **Tyvek® WRB** under the bottom of the sill flashing to maintain proper shingling.

### STEP 5

Tape all vertical seams with **DuPont™ Tyvek® Tape**. If the **Tyvek® WRB** is not being installed as an air barrier, **Tyvek® Tape** is not required on horizontal seams but is considered a recommended best practice. Use 3" **Tyvek® Tape** for the vertical seams of **DuPont™ Tyvek® CommercialWrap® D**, **Tyvek® StuccoWrap®** and **Tyvek® DrainWrap™**. Use **DuPont™ Tyvek® Metalized Tape** when taping **DuPont™ Tyvek® ThermaWrap® LE**.

### STEP 6 (FOR AIR BARRIER INSTALLATIONS)

When installing as an air barrier, the horizontal seams must be taped. The use of 3" **Tyvek® Tape** is required for both vertical and horizontal seams of **Tyvek® StuccoWrap®**, **Tyvek® DrainWrap™**, and **Tyvek® CommercialWrap® D** for air barrier installations.

### STEP 7 (FOR AIR BARRIER INSTALLATIONS)

Taping or sealing all terminations of **Tyvek® WRBs** (including, but not limited to, top-of-wall and bottom-of-wall interfaces) using **Tyvek® Tape**, **DuPont™ Flashing Tape**, or **DuPont™ StraightFlash™** is required when installing as an air barrier.\*

**NOTE: DuPont Self-Adhered Flashing Products**, or Tower® Residential Sealant or recommended sealant, are recommended for terminating **Tyvek® WRB** at top and bottom of wall, and at other horizontal and vertical locations. **Tyvek® Tape** can be used as indicated in this Installation Guideline to seal the **Tyvek® WRB** to most plastic top sheets of self-adhered products and to thin metal flashings (e.g. drip caps or through wall kick out flashings). **Tyvek® Tape** should **NOT** be used to seal **Tyvek® WRBs** to wood framing/sheathing, exterior gypsum sheathing, or masonry.

**NOTE:** See the table in the [Applicable Structures and Performance Criteria](#) section for more information on air barrier requirements.

For additional Installation Guidelines and more information about DuPont Performance Building Solutions, please visit [building.dupont.com](http://building.dupont.com) or call 1-833-338-7668.

\*Use **DuPont Self-Adhered Flashing Products** with a recommended adhesive/primer as applicable to seal the **Tyvek® WRB** directly to gypsum sheathing, concrete, wood, or other rough surfaces.

\*\*When installing the **Tyvek® WRB** as a water barrier only, skip sealing using Tower® Residential Sealant, or recommended sealant, is acceptable.

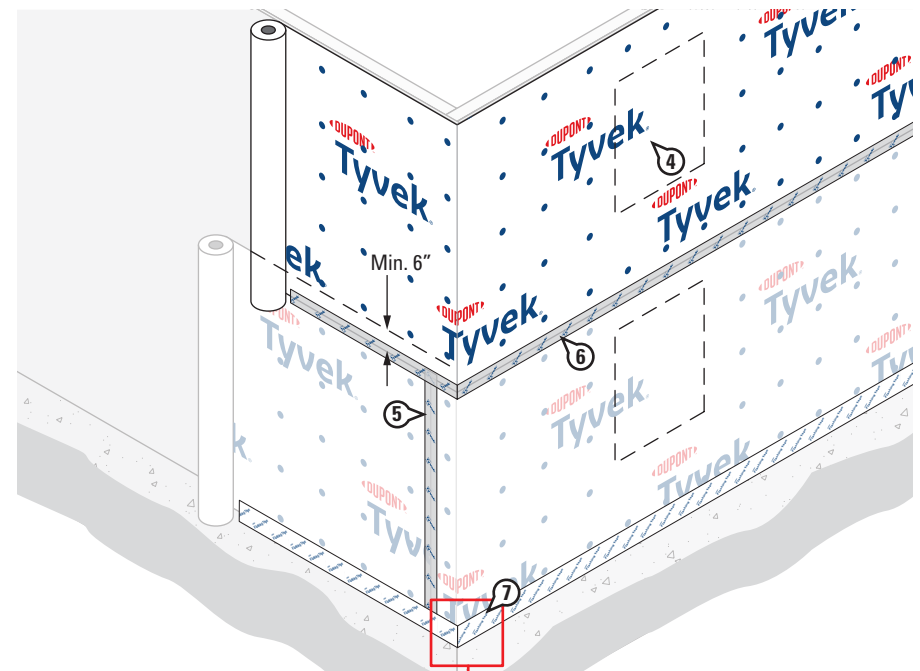

Examples of Sealing **Tyvek® WRB** at Bottom of Wall

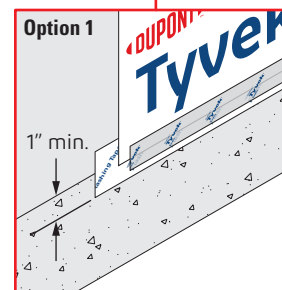

Seal interface of sheathing and foundation using **DuPont Self-Adhered Flashing Product**, overlap **Tyvek® WRB** onto **DuPont Self-Adhered Flashing Product** by a minimum of 1" and terminate using **Tyvek® Tape**.\*

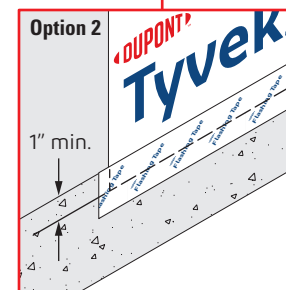

Overlap **Tyvek® WRB** onto foundation by a minimum of 1" and seal with **DuPont Self-Adhered Flashing Product**.\*

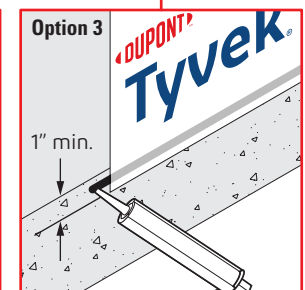

Overlap **Tyvek® WRB** onto foundation by a minimum of 1" and seal to foundation using Tower® Residential Sealant or recommended sealant.\*\*



**DuPont™ Tyvek® WRB Installation Instructions (Windows/Doors Installed BEFORE the Tyvek® WRB)**  
**DuPont Self-Adhered Flashing Products Integration**

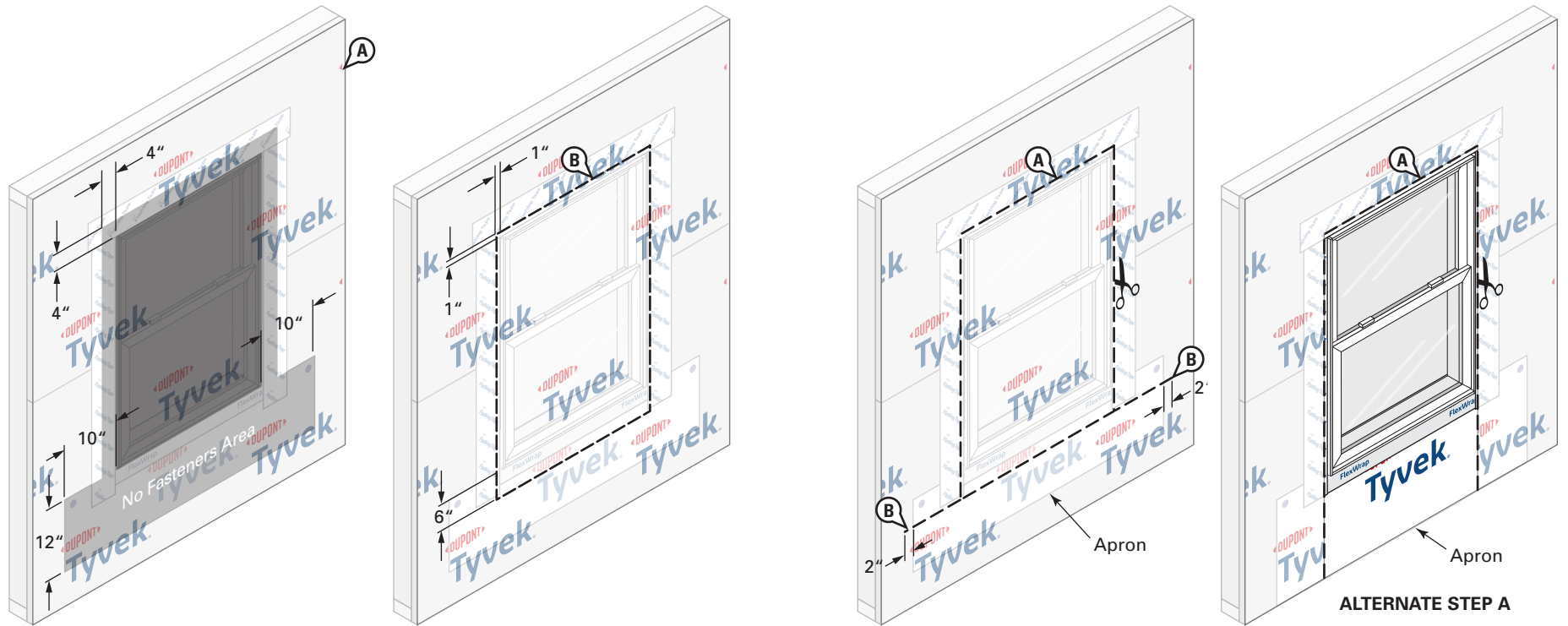

**STEP 1**

- A. Install the **Tyvek® WRB** as shown in the [DuPont™ Tyvek® WRB Installation Instructions](#) section of this document. Do not install fasteners within 4" of the window frame at jamba and head and within 12" of the window frame at sill or location of apron.
- B. Mark a perimeter on the **Tyvek® WRB** around the rough opening a minimum of 1" from the jamba and head of the window frame, and 6" below the sill of the window frame.

**STEP 2**

- A. Cut the **Tyvek® WRB** along perimeter marking to expose window. Do not cut through the **DuPont Self-Adhered Flashing Products** or **Tyvek® WRB** apron underneath.

**ALTERNATE STEP A:** If apron extends far enough below the sill rough opening to overlap the sill plate, base of wall flashing, or the **Tyvek® WRB** below, the **Tyvek® WRB** can be cut along jamba and head only to overlap apron.

- B. Create horizontal slits in the **Tyvek® WRB** at each lower corner of the perimeter cut that extend 1"– 2" **BEYOND** the **Tyvek® WRB** apron.

## DuPont™ Tyvek® WRB Installation Instructions (Windows/Doors Installed BEFORE the Tyvek® WRB) DuPont Self-Adhered Flashing Products Integration

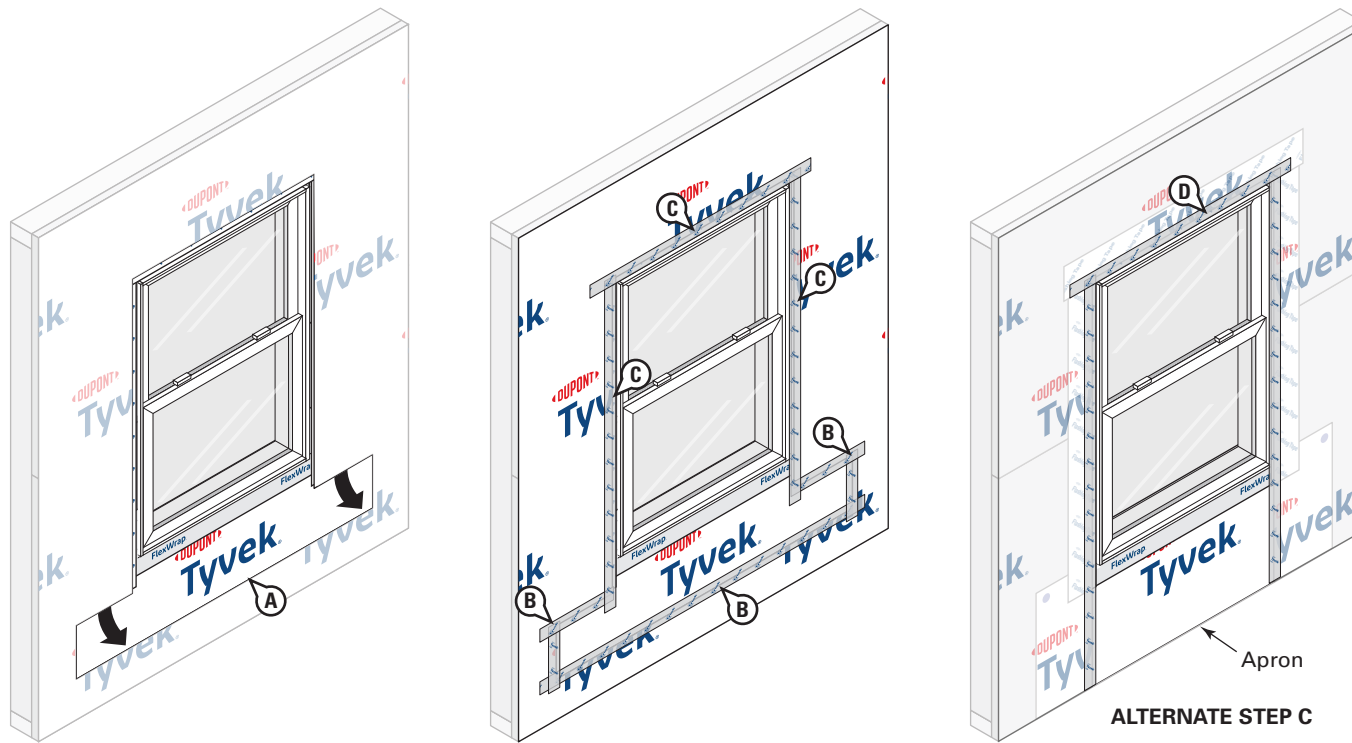

### STEP 3

#### Final Step

- A. Bring the bottom portion of the **Tyvek® WRB** apron through the sill perimeter cut and horizontal slits so it laps over the top layer of **Tyvek® WRB**.
- B. Working from bottom to top, install **DuPont™ Tyvek® Tape** to secure horizontal and vertical seams of the **Tyvek® WRB** apron.
- C. Install **Tyvek® Tape** along jambs and head to seal **Tyvek® WRB** around window. For a more robust termination, **DuPont™ Flashing Tape** or **DuPont™ StraightFlash™** can be used.
- D. **ALTERNATE STEP C:** If Step 2 Alternate Step A was followed, install **Tyvek® Tape** along the jambs extending to the bottom of the cut and then at head to seal the **Tyvek® WRB** around the window. For a more robust termination, **DuPont™ Flashing Tape** or **StraightFlash™** can be used.

## DuPont™ Tyvek® WRB Installation Instructions (Windows/Doors Installed BEFORE the Tyvek® WRB) Continuity

It is important to maintain the continuity of the **DuPont™ Tyvek® WRB** from bottom to top with proper shingling. Starting from the bottom of the structure, continue wrapping all the way up, overlapping the previous layer of **Tyvek® WRB** by a minimum of 6". Wrap the entire wall surface including unconditioned spaces.

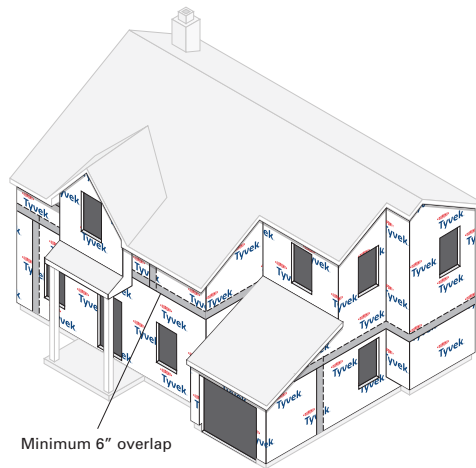

### Gable Ends

Completely cover the gable end with the **Tyvek® WRB** including a 6"-12" overlap at each outside corner. At top-of-wall, cut the **Tyvek® WRB** flush with the roof line. If rafters extend at the top of the wall to create a roof overhang, the **Tyvek® WRB** can be cut around each rafter or cut flush with the bottom of the rafters if the top edge of the **Tyvek® WRB** will extend above the soffit line.

**NOTE:** For air barrier installations, terminate the **Tyvek® WRB** to the sheathing using **DuPont Self-Adhered Flashing Product** or Tower® Residential Sealant (or recommended sealant).

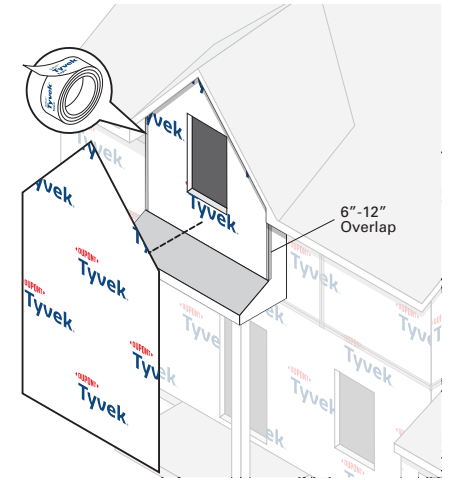

### Terminations

Lap **Tyvek® WRB** over all flashing (e.g. step flashing, wall to roof intersections and through wall flashings).

Weep screeds and expansion joints need to be integrated with flashings and the **Tyvek® WRB**.

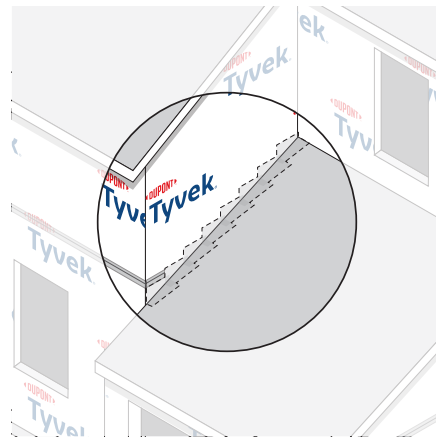

## DuPont™ Tyvek® WRB Installation Instructions (Windows/Doors Installed BEFORE the Tyvek® WRB) Continuity

### Installation of Metal Flashing at Façade Transitions

The following options for terminating metal flashing can be used for various exterior façade transitions. The cladding materials shown to the right are for general reference.

#### Option 1: Metal Flashing Terminated onto Tyvek® WRB

##### STEP 1

Install the “Z” or “L” metal flashing over the lower façade and onto the Tyvek® WRB with mechanical fasteners.

**NOTE:** Do not install Tyvek® WRB fasteners where the metal flashing or DuPont Self-Adhered Flashing Product will be installed.

##### STEP 2

Terminate the vertical leg of the metal flashing to Tyvek® WRB with DuPont™ Tyvek® Tape or DuPont™ Flashing Tape. When using DuPont™ Flashing Tape, ensure min. 2” adhesion to the WRB.

##### STEP 3

Install the upper façade according to the manufacturer’s instructions.

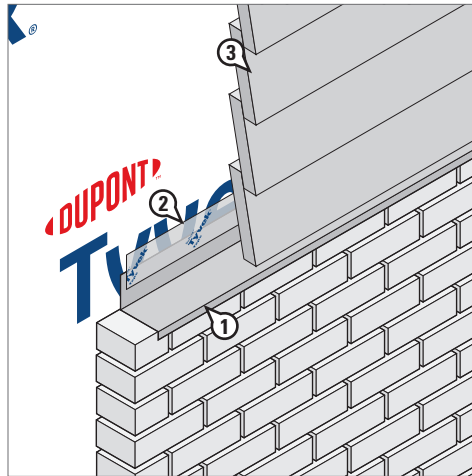

#### Option 2: Metal Flashing Terminated onto Sheathing

##### STEP 1

Install the first course of Tyvek® WRB so it extends a minimum of 2” BEYOND where the top edge of the lower façade will be located.

**NOTE:** Do not install Tyvek® WRB fasteners where the metal flashing or DuPont Self-Adhered Flashing Product will be installed.

##### STEP 2

Install the “Z” or “L” metal flashing along the top edge of the lower façade with the vertical leg overlapping the Tyvek® WRB.

##### STEP 3

Terminate the vertical leg of the metal flashing directly to the sheathing with DuPont Self-Adhered Flashing Product with minimum of 2” adhesion onto the sheathing. **NOTE:** A recommended adhesive/primer is required for gypsum sheathing.

##### STEP 4

Install the next course of Tyvek® WRB to overlap the DuPont Self-Adhered Flashing Products by a minimum of 2” and seal with DuPont™ Tyvek® Tape or Tower® Residential Sealant, or recommend sealant.

##### STEP 5

Install upper façade according to the manufacturer’s instructions.

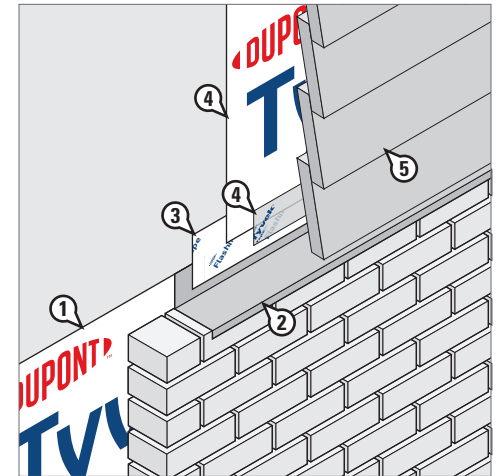

## DuPont™ Tyvek® WRB Installation Instructions (Windows/Doors Installed BEFORE the Tyvek® WRB)

### Continuity

#### Wall Protrusions with Horizontal Plane

For wall protrusions such as conditioned cantilevered spaces, build-outs, eye brows, etc. to ensure **Tyvek® WRB** continuity along the bottom horizontal plane. This detail can be used in conjunction with the general Horizontal Plane Transition detail to the right.

**NOTE:** If top of wall protrusion includes a horizontal plane, the condition should be treated as a roofing interface. **Tyvek® WRBs** and **DuPont Self-Adhered Flashing Products** should not be used on roofs.

- Install **Tyvek® WRB** on wall below horizontal plane.
- At outside edges of horizontal plane, cut a flap minimum 6" above bottom edge of cantilever. Fold up and temporarily secure in place to expose sheathing.
- Wrap the **Tyvek® WRB** along the horizontal plane and fold the **Tyvek® WRB** up the sides of the wall protrusion a minimum of 6". The **Tyvek® WRB** should also overlap the layer below by minimum 6".
- Tape all **Tyvek® WRB** seams with **DuPont™ Tyvek® Tape**.
- Seal the top edge of the **Tyvek® WRB** to the sheathing using **DuPont Self-Adhered Flashing Product**.
- Fold down flap at outside edges of horizontal plane and seal with **Tyvek® Tape**.
- Install upper course of **Tyvek® WRB**, overlapping bottom layer minimum 6".

**NOTE:** Make the inside corner as tight as possible using a 1" x 4" or similar.

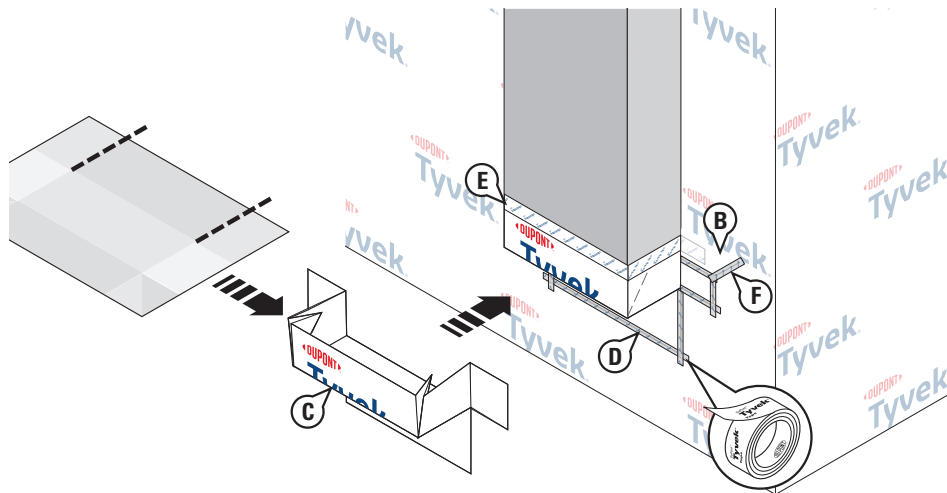

#### Horizontal Plane Transition

Detail isolates horizontal plane from vertical walls for water management

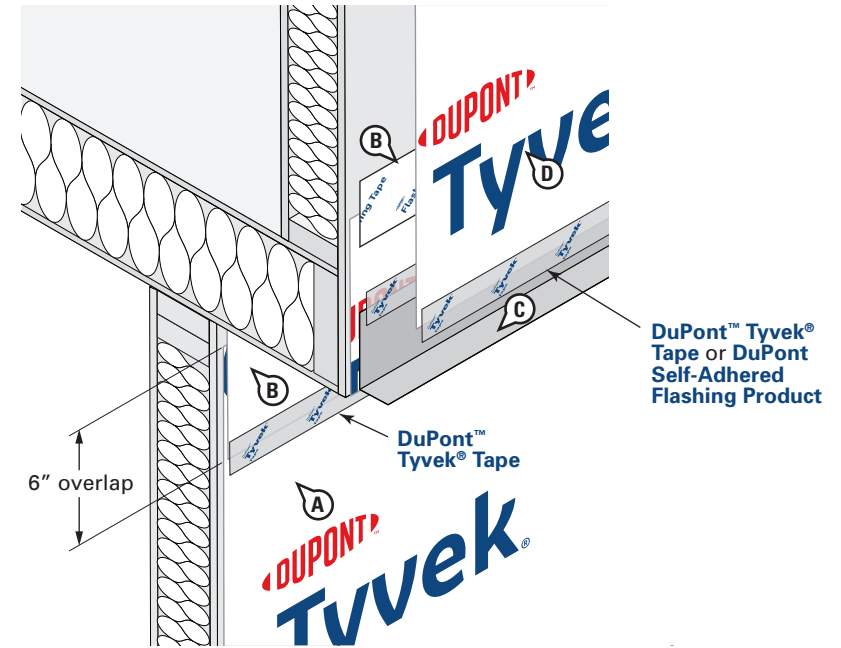

- Install **Tyvek® WRB** on wall below horizontal plane.
- Install **Tyvek® WRB** on horizontal plane, overlapping the **Tyvek® WRB** below by 6", and extend a minimum of 6" onto the vertical wall above. Install **Tyvek® Tape** to seal horizontal seam below and terminate onto upper wall with a **DuPont Self-Adhered Flashing Product**. **NOTE:** A recommended adhesive/primer is required for gypsum sheathing.
- Optional:** Install a kick-out flashing at outside corner as recommended best practice per plans and specifications. Terminate vertical leg of kick-out flashing with a **DuPont™ Tyvek® Tape** or **DuPont™ Flashing Tape**.
- Install **Tyvek® WRB** on wall above horizontal plane and terminate onto kick-out flashing with a **DuPont Self-Adhered Flashing Product** or **Tyvek® Tape**. **NOTE:** If kick-out flashing is not used, ensure a 6" overlap and seal the horizontal **Tyvek® WRB** seam with **Tyvek® Tape**.

## DuPont™ Tyvek® WRB Installation Instructions (Windows/Doors Installed BEFORE the Tyvek® WRB)

### Continuity

#### Inside and Outside Corners – OPTIONAL Use of 12" DuPont™ Flashing Tape

12" wide **DuPont™ Flashing Tape** can be used for additional protection during the construction process at inside and outside corners. The diagrams below show 12" **DuPont™ Flashing Tape** installed over the **Tyvek® WRB**; however, the flashing could alternatively be installed directly to the sheathing prior to the **Tyvek® WRB** installation. Ensure the **Tyvek® WRB** and 12" **DuPont™ Flashing Tape** are installed tightly into or around the inside or outside corners, respectively. If using multiple pieces of **DuPont™ Flashing Tape**, ensure a minimum of 2" overlap of each piece. For more information regarding the installation of 12" **DuPont™ Flashing Tape** at building corners, refer to the Installation Bulletin: [DuPont™ Flashing Tape for Inside and Outside Wall Corners](#).

Outside Corner

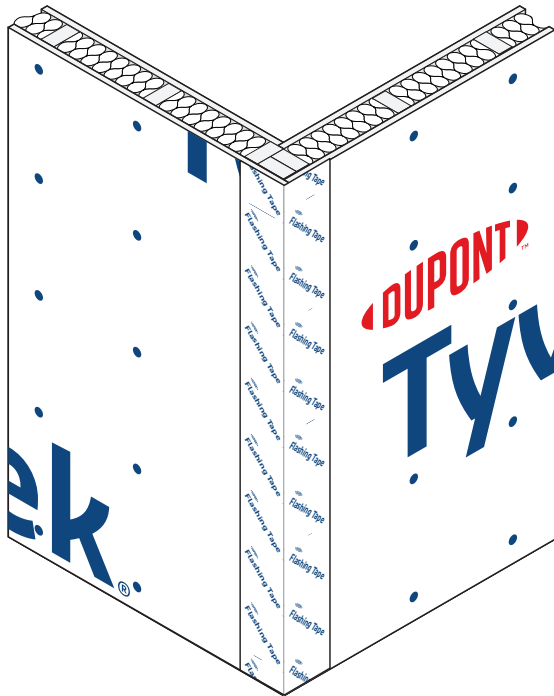

Inside Corner

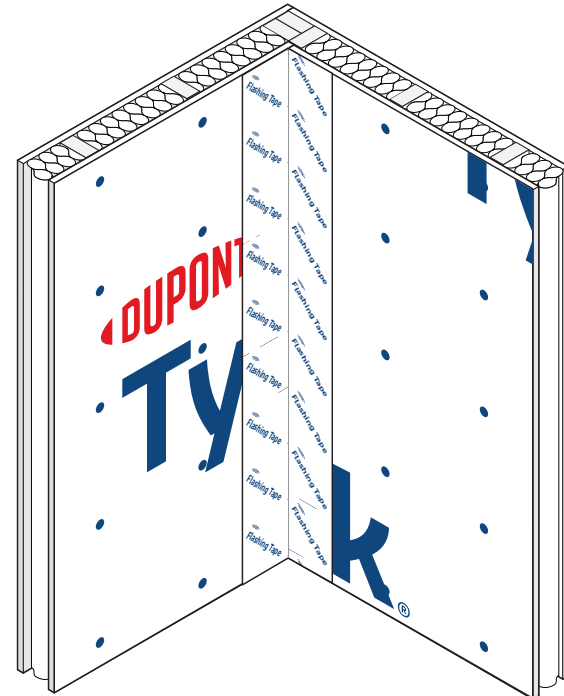

## DuPont™ Tyvek® WRB Installation Instructions (Windows/Doors Installed BEFORE the Tyvek® WRB)

### Continuity

#### Hybrid Wall – Transition to DuPont™ Tyvek® Fluid Applied Products

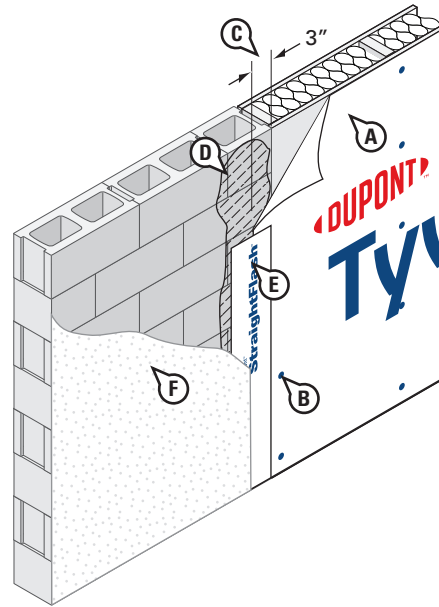

- A. Install **Tyvek® WRB** prior to application of **DuPont™ Tyvek® Fluid Applied WB+™**.
- B. Fasten the **Tyvek® WRB** to the stud adjoining the transition substrate.
- C. Cut the **Tyvek® WRB** so that approximately 3" will overlap the adjoining substrate.
- D. Fold back the 3" flap of **Tyvek® WRB** and prime adjoining substrate with a recommended adhesive/primer.
- E. Fold the **Tyvek® WRB** back down over the interface and seal it to the primed substrate using 4" **DuPont™ StraightFlash™**, overlapping both surfaces evenly by approximately 2". Apply pressure along entire surface of flashing. Refer to the [Special Considerations](#) section for additional information.
- F. Apply **Tyvek® Fluid Applied WB+™** onto wall surface, overlapping the **StraightFlash™** by a minimum of 2". Refer to the [DuPont™ Tyvek™ Fluid Applied WB+™ Wall and Substrate Guidelines](#) for additional information.

**Uncured Tyvek® Fluid Applied Products must not come in contact with Tyvek® WRBs due to potential impact on performance properties. Therefore, use of a spray guard or other physical barrier to avoid overspray onto the Tyvek® WRB is recommended.**

- G. Upon completion, inspect surface to ensure that **Tyvek® Fluid Applied WB+™** is continuous and free of any voids or pinholes.

**NOTE:** When spraying, the outer edge of **DuPont Self-Adhered Flashing Product** at the interface with the **Tyvek® Fluid Applied WB+™** can be treated with **DuPont Tyvek® Fluid Applied Flashing and Joint Compound+** tapered to the wall substrate to help ensure installation is free of pinholes and voids.

## DuPont™ Tyvek® WRB Installation Instructions (Windows/Doors Installed BEFORE the Tyvek® WRB)

### Continuity

#### Inside Corner Termination at Concrete Transition

**NOTE:** Ensure air barrier continuity at the concrete interfaces. If condition includes a transition from a Tyvek® WRB to a fluid applied membrane, DuPont™ StraightFlash™ is required to terminate the Tyvek® WRB.

#### Method 1

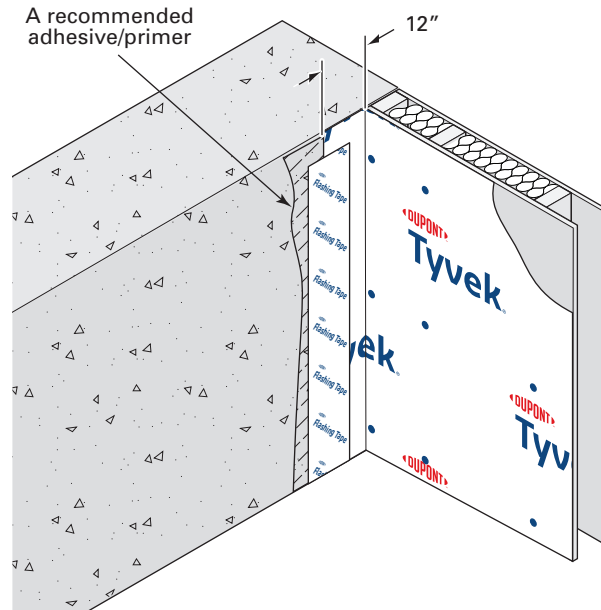

- Cut Tyvek® WRB so there is approximately 12" overlapping concrete.
- Mechanically fasten Tyvek® WRB to studs.
- Prime concrete with a recommended adhesive/primer.
- Seal Tyvek® WRB to concrete using DuPont™ Flashing Tape or StraightFlash™.

#### Method 2

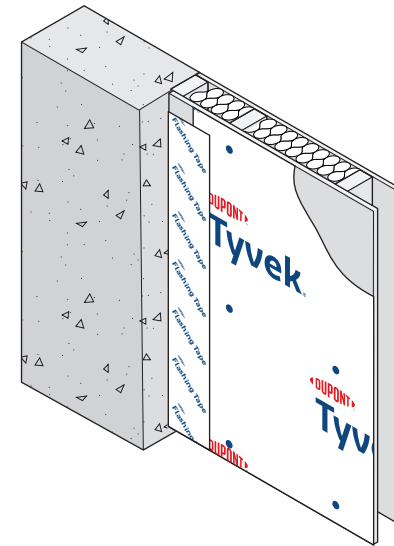

- Cut Tyvek® WRB to expose approximately 2" of the wall.
- Mechanically fasten Tyvek® WRB to studs.
- Seal Tyvek® WRB to the wall along the inside corner using DuPont™ Flashing Tape or StraightFlash™.

**NOTE:** Additional CAD details are available in the Technical Information section of [building.dupont.com](http://building.dupont.com).



# DuPont™ Tyvek® WRB Installation Instructions (Windows/Doors Installed BEFORE the Tyvek® WRB)

## Penetrations

Seal around plumbing pipes, HVAC components, electrical outlets, exterior lights, flashing panels, and other objects that penetrate the **Tyvek® WRB**. Always use positive shingling by installing **Tyvek® WRBs** and **DuPont Self-Adhered Flashing Products** from bottom to top, with upper layer installed over lower layer. **NOTE:** A backing support for flashing made of solid OSB or wood sheathing must be installed around the penetration before the **Tyvek® WRB** and flashing for open stud applications.

## Flashing Integral Flanged Products Installed AFTER DuPont™ Tyvek® WRB

### Method 1

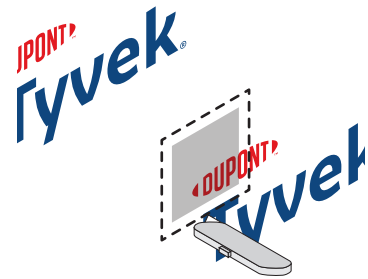

#### STEP 1

Install **Tyvek® WRB** and cut as necessary to accommodate integral flanged product.

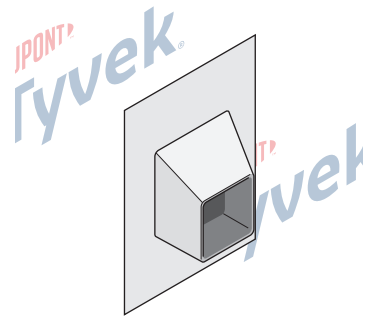

#### STEP 2

Install integral flanged product per manufacturer's instructions.

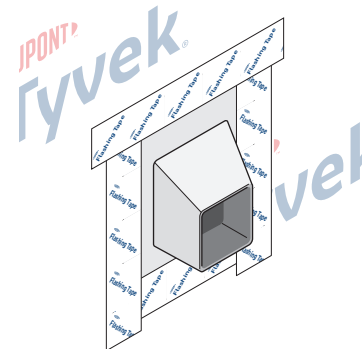

#### STEP 3

Install **DuPont Self-Adhered Flashing Product** (recommended best practice) or **Tyvek® Tape** onto bottom, sides, and top flanges, extending onto **Tyvek® WRB** by a minimum of 2". **NOTE:** Bottom piece is optional, but is recommended as a best practice and is required for air barrier installations.

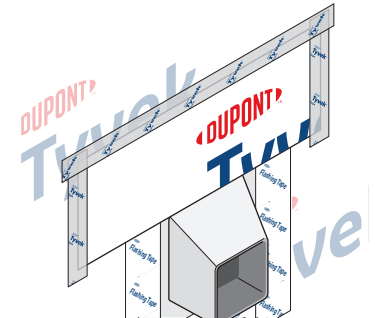

#### STEP 4 (OPTIONAL)

Install a piece of **Tyvek® WRB** to overlap the top edge of the **DuPont Self-Adhered Flashing Product**. Seal sides and top with **Tyvek® Tape**.

### Method 2

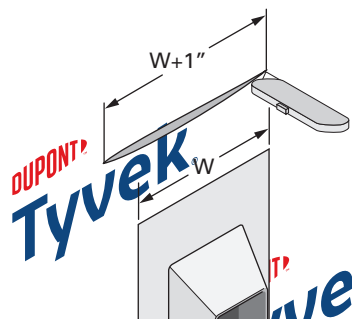

#### STEP 1

Install **Tyvek® WRB** and make horizontal cut a minimum of 1" wider than flange.

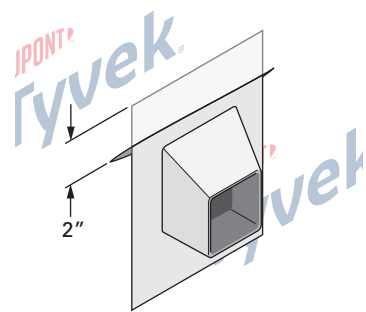

#### STEP 2

Slide top flange into slit with minimum 2" overlap of **Tyvek® WRB**, and install per manufacturer's instructions.

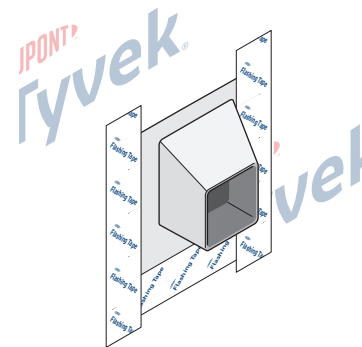

#### STEP 3

Adhere **DuPont Self-Adhered Flashing Product** (recommended best practice) or **Tyvek® Tape** bottom and side flanges, extending onto **Tyvek® WRB** by 2". **NOTE:** Bottom piece is optional, but is recommended as a best practice and is required for air barrier installations.

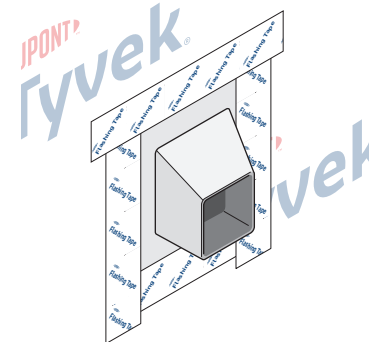

#### STEP 4

Install **DuPont Self-Adhered Flashing Product** (recommended best practice) or **Tyvek® Tape** to top flange, extending **BEYOND** the **DuPont Self-Adhered Flashing Product**, or **Tyvek® Tape**, on side flanges.

# DuPont™ Tyvek® WRB Installation Instructions (Windows/Doors Installed BEFORE the Tyvek® WRB)

## Penetrations

### Flashing Integral Flanged Products – Installed BEFORE the Tyvek™ WRB

#### Method 1

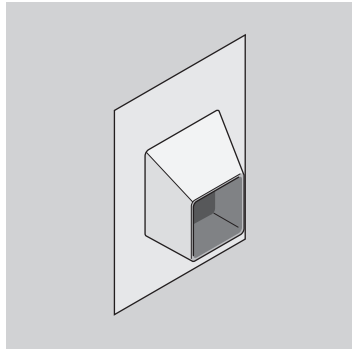

#### STEP 1

Install integral flanged product onto sheathing per manufacturer's instructions.

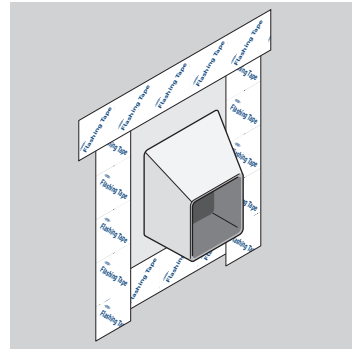

#### STEP 2

Install **DuPont Self-Adhered Flashing Product** onto flanges, extending onto sheathing by a minimum of 2". **NOTE:** A recommended adhesive/primer is required for gypsum sheathing.

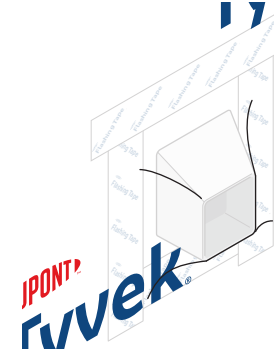

#### STEP 3

Install **Tyvek® WRB**.

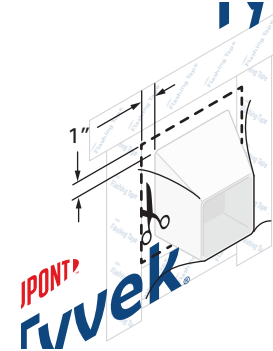

#### STEP 4

Make cut in **Tyvek® WRB**, ensuring a minimum of 1" gap for adhesion of **DuPont™ Tyvek® Tape**.

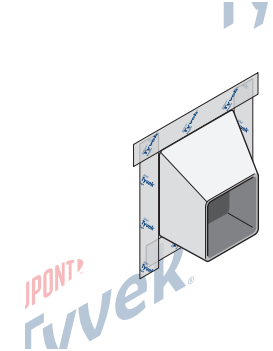

#### STEP 5

Seal edges of **Tyvek® WRB** with **Tyvek® Tape**.

#### Method 2

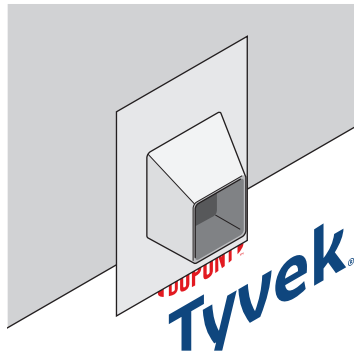

#### STEP 1

Install **Tyvek® WRB** under bottom flange.

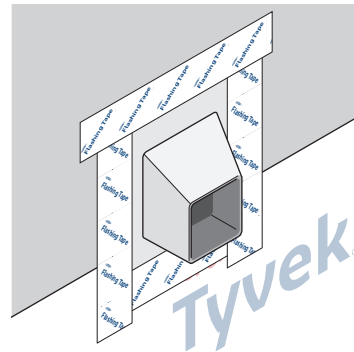

#### STEP 2

Adhere **DuPont Self-Adhered Flashing Product** onto sides and top flange. **NOTE:** Also install at bottom flange as a recommended best practice and for air barrier installations. **NOTE:** A recommended adhesive/primer is required for gypsum sheathing.

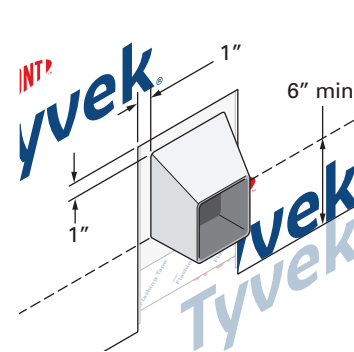

#### STEP 3

Install next course of **Tyvek® WRB** with a minimum of 6" overlap. Cut back 1" to expose flanges.

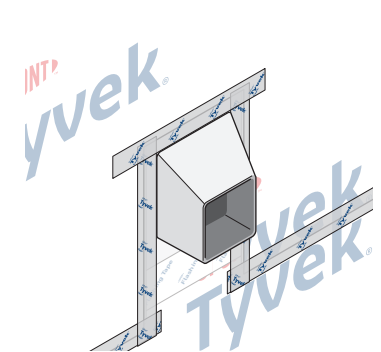

#### STEP 4

Seal seams using **Tyvek® Tape**.

## DuPont™ Tyvek® WRB Installation Instructions (Windows/Doors Installed BEFORE the Tyvek® WRB) Penetrations

Flashing Non-Flanged Products – Installed AFTER the Tyvek™ WRB

### Method 1: Flashing Non-Flanged Products Using DuPont™ FlexWrap™ EZ

**NOTE:** Ensure FlexWrap™ EZ will not be exposed to UV after the installation of the facade.

For non-flanged products with O.D. GREATER than 2”

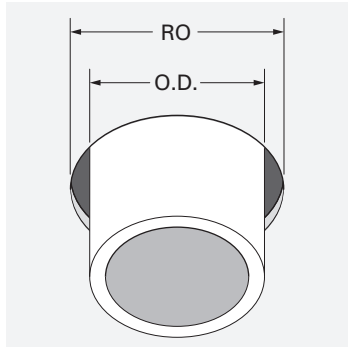

Use FlexWrap™ EZ only when penetration rough opening (RO) is not more than 1/2” larger than the outside diameter/dimension (O.D.) of non-flanged product.

**NOTE:** For more information regarding the installation of FlexWrap™ EZ, refer to the [Installation Information Bulletin for FlexWrap™ EZ](#).

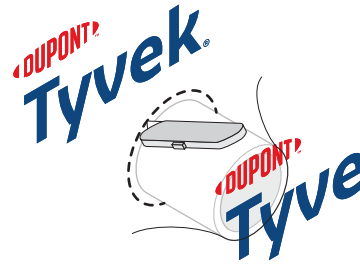

#### STEP 1

Install Tyvek® WRB over non-flanged product and cut around penetration.

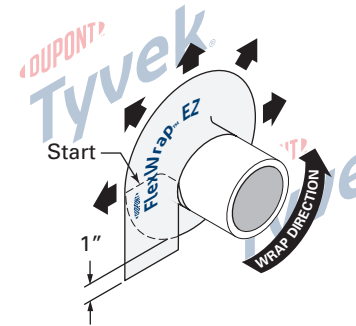

#### STEP 2

Cut a piece of FlexWrap™ EZ LONGER than the circumference of non-flanged product to ensure a minimum 1” overlap onto the Tyvek® WRB. Starting at the horizontal position on either side, adhere around penetration and onto Tyvek® WRB.

For non-flanged products with O.D. LESS than 2”

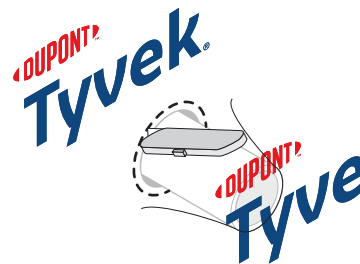

#### STEP 1

Install Tyvek® WRB over non-flanged product and cut around penetration.

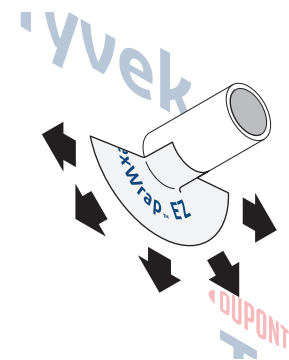

#### STEP 2

Cut a piece of FlexWrap™ EZ the length of 1/2 the circumference of the non-flanged product. Adhere onto bottom section and fan out onto Tyvek® WRB.

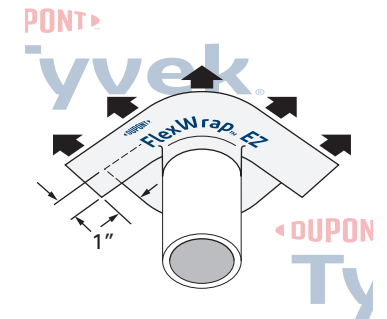

#### STEP 3

Cut a second piece of FlexWrap™ EZ the length of the pipe circumference. Adhere onto top section and fan out onto face of wall with a minimum of 1” overlap of the edges of FlexWrap™ EZ below.

## DuPont™ Tyvek® WRB Installation Instructions (Windows/Doors Installed BEFORE the Tyvek® WRB) Penetrations

### Method 2: Flashing Non-Flanged Products Using DuPont™ FlexWrap™

**NOTE:** Ensure **FlexWrap™** will not be exposed to UV after the installation of the facade.

#### FlexWrap™ installed onto Tyvek® WRB around penetration

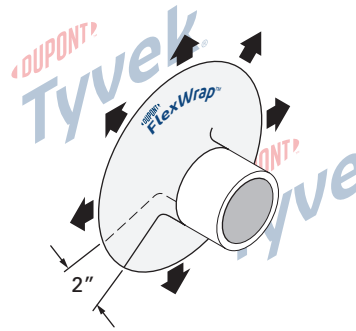

#### STEP 1

Install **Tyvek® WRB** over non-flanged product and cut around penetration.

#### STEP 2

Starting at the horizontal position on either side, install **FlexWrap™** around penetration with a minimum 2" overlap.

#### FlexWrap™ adhered to sheathing above penetration\*

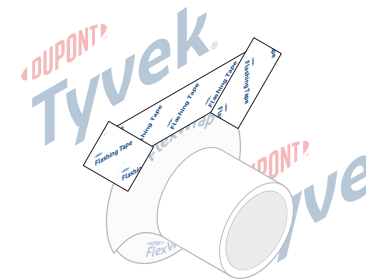
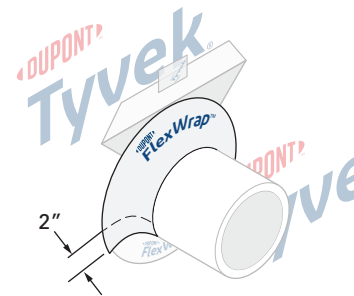
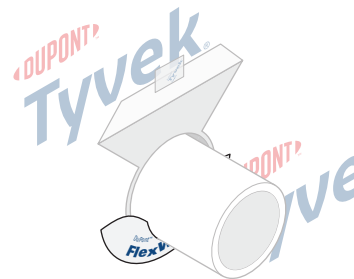
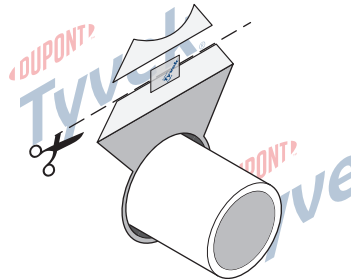
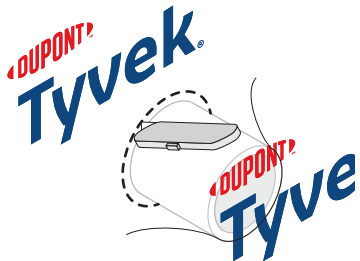

#### STEP 1

Install **Tyvek® WRB** over non-flanged product and cut around penetration.

#### STEP 2

Cut diagonal flap in **Tyvek® WRB**, trim back ~1" to make straight edge, and temporarily secure.

#### STEP 3

Install **FlexWrap™** around bottom of penetration.

#### STEP 4

Install **FlexWrap™** around top of penetration, overlapping bottom layer of **FlexWrap™** by 2" on either side.

#### STEP 5

Flip down and secure head flap using **DuPont Self-Adhered Flashing Product** or **DuPont™ Tyvek® Tape**.

\*Allows positive shingling of **Tyvek® WRB**

## DuPont™ Tyvek® WRB Installation Instructions (Windows/Doors Installed BEFORE the Tyvek® WRB)

### Flashing Beam Penetrations

**NOTE:** A backing support for flashing made of solid OSB or wood sheathing must be installed around the beam before the **Tyvek® WRB** and flashing for open stud applications.

**OPTIONAL:** **DuPont™ FlexWrap™ EZ** may be used in place of **DuPont™ FlexWrap™** (STEP 3) when the beam penetration rough opening (RO) is not more than 1/2" larger than the outside diameter/dimension (O.D.) of the beam. Refer to the detail [Method 1 – Flashing Non-Flanged Products Using DuPont™ FlexWrap™ EZ](#) in this guide.

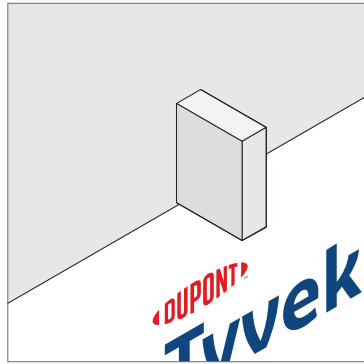

#### STEP 1

Install the first course of **Tyvek® WRB** so the top edge is flush with the bottom of the beam.

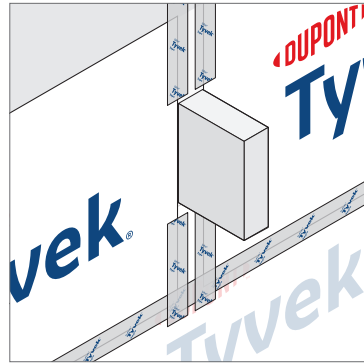

#### STEP 2

Cut pieces of **Tyvek® WRB** to fit between beams. The pieces should extend a minimum of 7" above the beams and overlap the course below by a minimum of 6". Seal the vertical seams with **DuPont™ Tyvek® Tape**. **NOTE:** For air barrier installations, seal all vertical and horizontal seams.

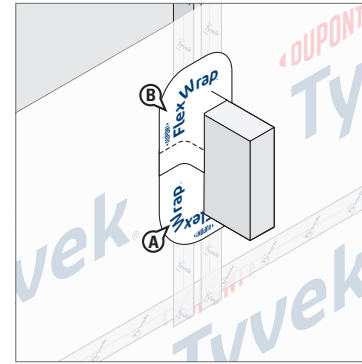

#### STEP 3

Seal around the beam using two pieces of 6" wide **FlexWrap™** (or **FlexWrap™ EZ** as captured in the note above).

- Cut the first piece of **FlexWrap™** long enough wrap around the bottom half of the beam. Break the perforation in the release paper by folding the **FlexWrap™** top sheet to the inside of the fold. With the **FlexWrap™** still folded, remove the narrow piece of release paper and adhere the exposed butyl to the bottom and up each side of the beam. Remove the remaining release paper and fan the **FlexWrap™** out onto the **Tyvek® WRB** on the face of the wall.
- Cut the second piece of **FlexWrap™** long enough to wrap around the top half of the beam, overlapping the first piece of **FlexWrap™** on each side by 2". Install along the top of the beam and down each side, overlapping the lower piece of **FlexWrap™** by 2" using the method above.

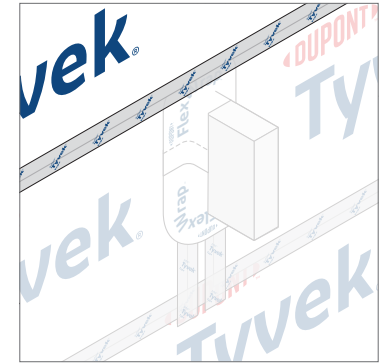

#### STEP 4

Install the top course of the **Tyvek® WRB**, overlapping the **Tyvek® WRB** below with 1" gap above the beam. Tape all vertical seams with **Tyvek® Tape**.

**NOTE:** For air barrier installations, seal all vertical and horizontal seams.

## DuPont™ Tyvek® WRB Installation Instructions (Windows/Doors Installed BEFORE the Tyvek® WRB) Handling Tears and Holes

### Tears

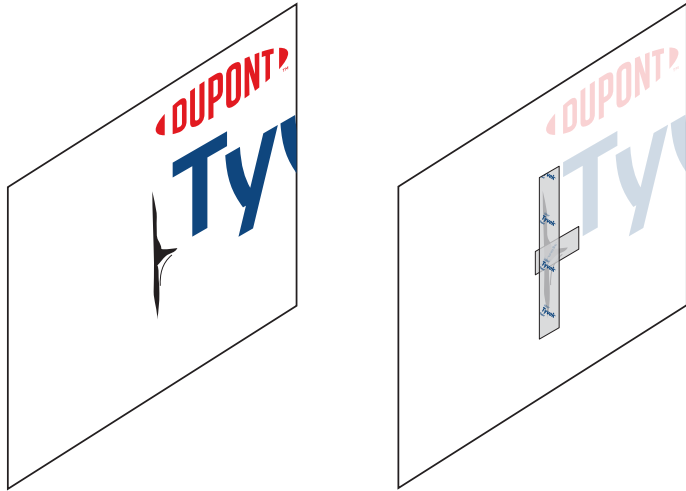

#### STEP 1

During the course of installing the **Tyvek® WRB**, minor tears may occur.

#### STEP 2

All tears should be sealed with **DuPont™ Tyvek® Tape** (2" or 3") or **DuPont Self-Adhered Flashing Products**.

### Holes

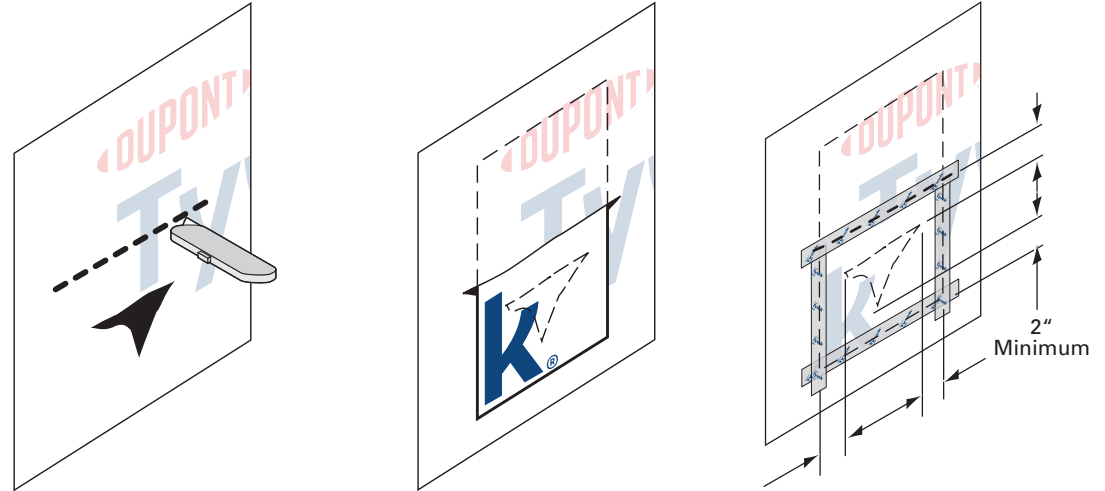

#### STEP 1

Larger holes (greater than 1") may require cutting a piece of **Tyvek® WRB** to cover the hole, maintaining proper shingling. Cut a slit 2" above the hole and extending a minimum of 2" on each side of the hole.

#### STEP 2

Measure and cut a piece of **Tyvek® WRB** to fit into the slit and cover the hole. Tuck the cut piece of **Tyvek® WRB** into the slit.

#### STEP 3

Seal seams with **Tyvek® Tape** along the perimeter by starting at the bottom of the patch, shingling upper tape over bottom tape.

## DuPont™ Tyvek® WRB Installation Instructions (Windows/Doors Installed BEFORE the Tyvek® WRB) Tilt Wall Instructions

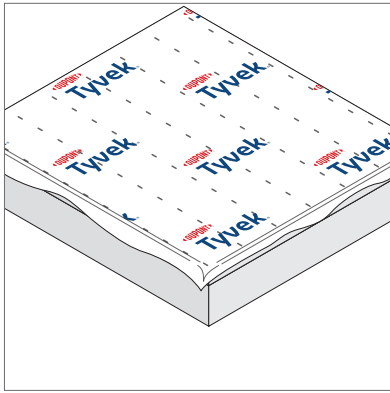

### STEP 1

Unroll and secure **Tyvek® WRB** over the wall panel. Leave enough excess at sides and bottom to ensure a minimum 6" overlap of the **Tyvek® WRB** onto adjacent wall panels and minimum 1" overlap of the foundation below. These flaps allow for a **Tyvek® WRB-to-Tyvek® WRB** seal with adjacent sides. Position/cut the **Tyvek® WRB** so that it is flush with the top of the wall. When taping, make sure the stud marks printed on the **Tyvek® WRB** line up with the first stud and that the roll is plumb.

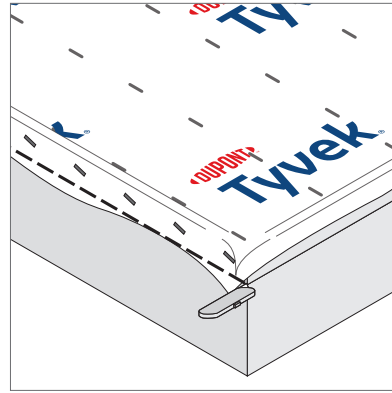

### STEP 2

When starting a wall section, fold the beginning side flap over the vertical side of the stud and secure. Trim off excess. Only one side flap is needed (either left or right side of wall panel) to overlap adjacent panels; however, having the flap on the same side of each panel will ensure proper overlap from panel to panel and at building corners. Fold the flap that will overlap the adjacent panel onto the exterior face of the panel and temporarily secure with small pieces of **DuPont™ Tyvek® Tape** as needed to assist with raising the panel upright. Ensure that the bottom flap overhangs enough so that, when the wall is tilted upright, it overlaps the sill plate.

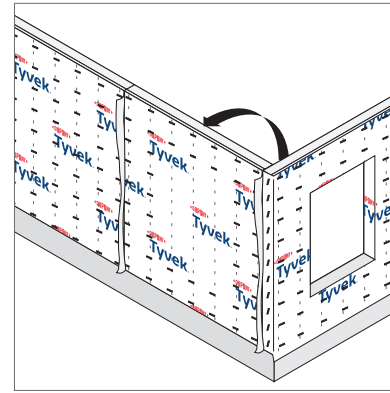

### STEP 3

As each wall section is raised, ensure that the bottom flaps overlap the sill plate and that the side flaps are on the exterior of the house.

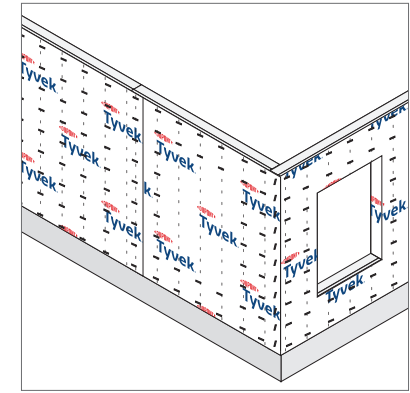

### STEP 4

Fasten the side flaps and terminate the bottom flap in accordance with [Option 1-3](#), depending on bottom of wall condition, in the [DuPont™ Tyvek® WRB Installation Instructions](#) section.

### STEP 5

All vertical seams shall be taped with **Tyvek® Tape**. When installing as an air barrier, also tape all horizontal seams. Taping all vertical and horizontal seams, and taping or sealing all terminations (including, but not limited to, roof-wall interfaces and sill plates) is required when installing **Tyvek® WRBs** as air barriers. Use 3" **Tyvek® Tape** when taping horizontal laps of **DuPont™ Tyvek® StuccoWrap®** and **Tyvek® DrainWrap™**. Use **DuPont™ Tyvek® Metalized Tape** when taping **DuPont™ Tyvek® ThermaWrap® LE**.

### STEP 6

After **Tyvek® WRB** is installed refer to the applicable window and door flashing conditions in this guide.



## Façade Considerations

Water-resistive barrier performance is dependent upon the ability of the facade to drain. **DuPont™ Tyvek® HomeWrap®** and **Tyvek® CommercialWrap®** provide >90% drainage efficiency, and **Tyvek® DrainWrap™**, **Tyvek® StuccoWrap®**, and **Tyvek® CommercialWrap® D** provide >98% drainage efficiency when tested in accordance with ASTM E2273. The following must be considered for specific facades:

### Stucco

When stucco is installed over wood-based sheathing, the 2018 International Residential Code (Section R703.7.3) requires a water-resistive vapor-permeable barrier with a performance at least equivalent to two layers of Grade D paper or a water-resistive barrier which is separated from the stucco by an intervening, substantially nonwater-absorbing layer or designed drainage space. "The individual layers shall be installed independently such that each layer provides a separate continuous plane and any flashing intended to drain to the water-resistive barrier is directed between the layers. **DuPont™ Tyvek® WRBs** used behind stucco should be separated from the stucco by a second layer of **Tyvek® WRB**, a layer of Grade D building paper, felt, rigid foam board or the paper backing of paper-backed lath. **DuPont™ Tyvek® DrainVent™ Rainscreen** can also be used as the intervening layer over the WRB. The first layer (directly over sheathing or studs) serves as the wall system's water-resistive barrier and is integrated with window and door flashings, the weep screed at the bottom of the wall and any through wall flashings or expansion joints. Lath shall be installed over the intervening layer in accordance with ASTM C1063 *Standard Specification for Installation of Lathing and Furring to Receive Interior and Exterior Portland Cement-Based Plaster* and applicable codes. Rigid foam board, when installed over **Tyvek® WRB** as an intervening layer, will provide enhanced structural support to the **Tyvek® WRB** and may reduce the required number of fasteners used for the attachment of the **Tyvek® WRB** if installed as soon as practically possible. **Tyvek® StuccoWrap®**, **Tyvek® DrainWrap™** or **Tyvek® CommercialWrap® D** is recommended for this application, since these products provide >98% drainage efficiency when tested in accordance with ASTM E2273.

**Tyvek® HomeWrap®** and **Tyvek® CommercialWrap®** provide >90% drainage efficiency when tested in accordance with ASTM E2273. **DuPont Self-Adhered Flashing Products** or recommended alternate may be required for high performance installations.

### Brick (or Other Stacked/Anchored Masonry Veneers)

The 2018 International Residential Code (Section R703.8.4) requires a nominal 1 inch airspace separating the brick from the water-resistive barrier (WRB). The Brick Industry Association recommends a 1 inch air-space in front of wood stud construction and a 2 inch air-space in front of steel stud construction. Consistent with these requirements and recommendations, **Tyvek® WRBs** shall be separated from the brick veneer by a nominal 1 inch air-space. Window and door flashing, and through-wall flashing shall be integrated with the **Tyvek® WRB** layer ensuring proper shingling. For maximum moisture management and drying of the wall system the airspace in front of the

**Tyvek® WRB** shall be vented to the exterior at the top and bottom of the wall. Some types of brick ties will act as additional fasteners for **Tyvek® WRBs**, and, if installed as soon as practically possible after the **Tyvek® WRB**, may reduce the required number of fasteners used for the initial attachment of the **Tyvek® WRB**.

### Stone Veneer (or Other Adhered Masonry Veneers)

The 2018 International Residential Code (Section R703.12.3) states a water-resistive barrier shall be installed as required by Section R703.2 and shall comply with the requirements of Section R703.7.3 which "requires a water-resistive vapor-permeable barrier with a performance at least equivalent to two layers of Grade D paper or a water-resistive barrier which is separated from the stucco by an intervening, substantially nonwater-absorbing layer or designed drainage space." "The individual layers shall be installed independently such that each layer provides a separate continuous plane and any flashing intended to drain to the water-resistive barrier is directed between the layers." The water-resistive barrier shall lap over the exterior of the attachment flange of the screed or flashing provided in accordance with Section R703.12.2.

When used behind stone veneer, **Tyvek® WRBs** shall be installed in a similar manner as they are installed behind stucco. The **Tyvek® WRB** should be separated from the stone and mortar by a second layer of **Tyvek® WRB**, a layer of grade D building paper, felt, exterior continuous foam insulation or the paper backing of paper-backed lath. **Tyvek® DrainVent™ Rainscreen** can also be used as the intervening layer over the WRB. The first layer (directly over sheathing or studs) serves as the wall system's air and water barrier and shall be integrated with window and door flashings, the weep screed at the bottom of the wall and any through wall flashing or expansion joints. Lath shall be installed over the intervening layer (second layer) in accordance with ASTM C1063 *Standard Specification for Installation of Lathing and Furring to Receive Interior and Exterior Portland Cement-Based Plaster* and applicable codes. When exterior continuous foam insulation is used as the second layer, it is installed over the **Tyvek® WRB**. **Tyvek® StuccoWrap®**, **Tyvek® DrainWrap™** or **Tyvek® CommercialWrap® D** is recommended for this application, since these products provide >98% drainage efficiency when tested in accordance with ASTM E2273. **Tyvek® HomeWrap®** and **Tyvek® CommercialWrap®** provide >90% drainage efficiency when tested in accordance with ASTM E2273. **DuPont Self-Adhered Flashing Products** or recommended alternate patch is required for high performance installations.



## Façade Considerations

### Wood Siding

**DuPont™ Tyvek® WRBs** and wood siding shall be installed according to manufacturer's instructions, industry standards and applicable codes. As recommended by the Western Red Cedar Lumber Association and U. S. Forest Product Laboratory, wood siding should be primed on all six sides before installation. When installed over exterior continuous insulation, the Western Red Cedar Lumber Association and other wood siding manufacturers recommend that furring strips are used to create an air space between foam sheathing and siding. Other recommendations that should be followed to minimize potential problems are:

- Use thicker siding patterns in widths of 8 inches or less. Thick, narrow siding is more stable than thinner, wider patterns and better able to resist dimensional changes.
- Use kiln-dried siding over rigid foam sheathing.
- Proper pre-finishing is essential.
- Use light color finish coats to maximize heat reflection and reduce dimensional movement.
- **DuPont™ Tyvek® StuccoWrap®**, **DuPont™ Tyvek® DrainWrap™** or **DuPont™ Tyvek® CommercialWrap® D** applied over the foam sheathing is recommended for this application.

In high exposure installations, enhanced drainage and water management may be provided by using **Tyvek® StuccoWrap®**, **Tyvek® DrainWrap™** or **Tyvek® CommercialWrap® D**, by installing **DuPont™ Tyvek® DrainVent™ Rainscreen** or other drainage mesh over the water-resistive barrier, or by creating rainscreen cladding with a larger air space behind the siding using furring strips. If furring is installed over the **Tyvek® WRB** to create a rainscreen, the primary fastener spacing can exceed 18". **DuPont™ Tyvek® HomeWrap®** and **Tyvek® CommercialWrap®** provide >90% drainage efficiency, and **Tyvek® DrainWrap™**, **Tyvek® StuccoWrap®**, and **Tyvek® CommercialWrap® D** provide >98% drainage efficiency when tested in accordance with ASTM E2273.

### Fiber Cement Siding

**Tyvek® WRBs** and fiber cement siding shall be installed according to manufacturer's instructions and industry standards. In high exposure installations, enhanced drainage and water management may be provided by using **Tyvek® StuccoWrap®**, **Tyvek® DrainWrap™** or **Tyvek® CommercialWrap® D**, by installing **Tyvek® DrainVent™ Rainscreen** or other drainage mesh over the water-resistive barrier, or by creating rainscreen cladding with a larger air space behind the siding using furring strips. If furring is installed over the **Tyvek® WRB** to create a rainscreen, the primary fastener spacing can exceed 18". In high wind areas at gable end walls, FEMA recommends fiber cement siding be installed over wood sheathing rather than over plastic foam sheathing.

**Tyvek® WRBs** and fiber cement siding shall be installed according to manufacturer's

instructions, industry standards and applicable codes. **Tyvek® HomeWrap®** and **Tyvek® CommercialWrap®** provide >90% drainage efficiency, and **Tyvek® DrainWrap™**, **Tyvek® StuccoWrap®**, and **Tyvek® CommercialWrap® D** provide >98% drainage efficiency when tested in accordance with ASTM E2273.

### Vinyl Siding

Vinyl Siding is installed directly over **Tyvek® WRBs**. Vinyl siding shall be installed in accordance with manufacturer's instructions, industry standards and applicable codes, including ASTM D4756-15 *Standard Practice for Installation of Rigid Poly (Vinyl Chloride) (PVC) Siding and Soffit*. In high wind areas at gable end walls, FEMA recommends vinyl siding be installed over wood sheathing rather than over plastic foam sheathing.

### EIFS

**Tyvek® WRBs** and EIFS cladding shall be installed according to manufacturer's instructions and industry standards. In order to promote drainage, it is recommended that **Tyvek® StuccoWrap®**, **Tyvek® DrainWrap™** or **Tyvek® CommercialWrap® D** be installed behind the exterior insulation. Window and door flashing, and through wall flashing shall be integrated with the **Tyvek® WRB** layer ensuring proper shingling. The successful installation and performance of EIFS cladding is dependent upon the proper design and construction of the adjacent materials and systems of the structure.

**Tyvek® HomeWrap®** and **Tyvek® CommercialWrap®** provide >90% drainage efficiency, and **Tyvek® DrainWrap™**, **Tyvek® StuccoWrap®**, and **Tyvek® CommercialWrap® D** provide >98% drainage efficiency when tested in accordance with ASTM E2273.

### Metal Panel

**Tyvek® WRBs** and metal panel cladding systems shall be installed according to manufacturer's instructions and industry standards. **DuPont™ StraightFlash™**, **DuPont™ Flashing Tape**, or recommended alternate patch can be installed behind all metal installation brackets and hat-channels fasteners for additional air and water infiltration resistance.

**NOTE:** The maximum in-service temperature for **Tyvek® WRBs**, **DuPont Self-Adhered Flashing Products**, and **DuPont™ Tyvek® Fluid Applied Products** is 180°F.

## Façade Considerations

### Exterior Insulation

When using **DuPont™ Tyvek® WRBs** with **DuPont Exterior Continuous Insulation Products**, please refer to the Installation Bulletin: [Integrating DuPont Building Envelope Solutions Products with DuPont Exterior Continuous Insulation](#) for guidance on fasteners and product installation. **Tyvek® WRBs** and exterior continuous insulation shall be installed according to the manufacturer's instructions and industry standards.

**Tyvek® WRBs** can be installed either over the rigid exterior continuous insulation or underneath between the sheathing and the exterior insulation. In order to promote drainage, it is recommended that **Tyvek® StuccoWrap®**, **Tyvek® DrainWrap™** or **Tyvek® CommercialWrap® D** be used when installing the **Tyvek® WRB** layer between the sheathing and exterior continuous insulation. Window flashing, door flashing, and through wall flashing shall be integrated with the **Tyvek® WRB** layer ensuring proper shingling. The successful installation and performance of exterior continuous insulation is dependent upon the proper design and construction of adjacent materials and systems of the structure.

**NOTE:** **Tyvek® DrainVent™ Rainscreen** and **DuPont™ RainVent™ Battens** can be used to improve the ventilation and draining space behind wood, stucco or stone masonry, vinyl, and fiber cement cladding types.

## Product Composition and UV Stability

**DuPont™ Tyvek® WRBs** used in construction products are made from 100% flash spunbonded high density polyethylene fibers which have been bonded together by heat and pressure, without binders or fillers, into a tough durable sheet structure. Additives have been incorporated into the polyethylene to provide ultraviolet light resistance. DuPont requires that **DuPont™ Tyvek® HomeWrap®**, **Tyvek® DrainWrap™**, **Tyvek® StuccoWrap®**, and **Tyvek® ThermaWrap® LE** be covered within 4 months (120 days) of installation. DuPont requires that **DuPont™ Tyvek® CommercialWrap®** and **Tyvek® CommercialWrap® D** be covered within 9 months (270 days) of installation.

**DuPont Self-Adhered Flashing Products** are made from a synthetic rubber adhesive, and a top sheet of flash spunbonded high density polyethylene fibers or polypropylene film. Additives have been incorporated into these materials to provide ultraviolet light resistance. DuPont requires that **DuPont™ FlexWrap™**, **DuPont™ FlexWrap™ EZ**, **DuPont™ StraightFlash™** and **DuPont™ VersaFlange™** be covered within nine months (270 days) of installation. DuPont requires that **DuPont™ Flashing Tape** be covered within 4 months (120 days) of installation.

**DuPont™ Tyvek® Fluid Applied Products** are formulated to include elastomeric polymers that cure to a continuous, fully-adhered, tough, durable membrane. Additives have been incorporated to provide ultraviolet light resistance.

DuPont requires that the **DuPont™ Tyvek® Fluid Applied WB+™** and **DuPont™ Tyvek® Fluid Applied Flashing and Joint Compound+** are to be covered within 9 months (270 days) of installation.

### Design Considerations

When installed in conjunction with other building materials, **Tyvek® WRBs**, **DuPont Self-Adhered Flashing Products**, and **Tyvek® Fluid Applied Products** must be properly shingled with these materials such that water is diverted to the exterior of the wall system. **Tyvek® WRBs** and **Tyvek® Fluid Applied WB+™** are secondary weather barriers. The outer facade is the primary barrier. Follow facade manufacturer's installation and maintenance requirements for all facade systems in order to maintain water holdout properties and ensure performance of **Tyvek® WRBs** and **Tyvek® Fluid Applied WB+™**. Do not install on a wall that does not feature a continuous path for moisture drainage. Any standing water must be allowed to drain off the membrane.

Use of additives, coatings or cleaners on or in the facade system may impact the performance of **DuPont™ Tyvek® WRBs** and **Tyvek® Fluid Applied WB+™**. DuPont Building Envelope Solutions Products are to be used as outlined in this installation guideline. **DuPont Self-Adhered Flashing** and **Tyvek® Fluid Applied Flashing and Joint Compound+** should only be used to seal penetrations and flash openings in buildings. **Tyvek® WRBs**, **Tyvek® Fluid Applied Products**, and **DuPont Self-Adhered Flashing Products** are not to be

used in roofing applications. For superior protection against bulk water penetration, DuPont suggests a system combining a quality exterior facade, a good secondary air and water barrier and exterior sheathing, high quality windows and doors, and appropriate flashing materials paying attention to proper installation of each component.

In a system where no exterior sheathing is used and **Tyvek® WRBs** are installed directly over the wall studs, exterior facade materials should be selected to ensure maximum protection against water intrusion. Careful workmanship and proper installation of each component is very important.

Depending on job site conditions, it is possible that stains may appear, but will not alter performance of the **Tyvek® Fluid Applied Product**.

### Safety and Handling

#### Warning

**Tyvek® WRBs** are slippery and should not be used in any application where they will be walked on. In addition, because they are slippery, DuPont recommends using kickjacks, scaffolding, or lifts for exterior work above the first floor. If ladders must be used, extra caution must be taken to use them safely by following the requirements set forth in ANSI Standards 14.1, 14.2, and 14.5 for ladders made of wood, aluminum, and fiberglass, respectively. **DuPont™ Tyvek®** is combustible and should be protected from flames and other high heat sources. **DuPont™ Tyvek®** will melt at 275°F (135°C)

and if the temperature of **DuPont™ Tyvek®** reaches 750°F (400°C), it will burn and the fire may spread and fall away from the point of ignition. For more information, call 1-833-338-7668.

**DuPont Self-Adhered Flashing Products** and their release paper are slippery and should not be walked on. Remove release paper from work area immediately.

**DuPont Self-Adhered Flashing Products** will melt at temperatures greater than 250°F (121°C). **DuPont Self-Adhered Flashing Products** are combustible and should be protected from flames and other high heat sources. **DuPont Self-Adhered Flashing Products** will not support combustion if the heat source is removed. However, if burning occurs, ignited droplets may fall away from the point of ignition. For more information, call 1-833-338-7668.

Tower® Residential Sealant (formerly DuPont™ Residential Sealant) is irritating to skin, eyes, and respiratory tract. For proper usage, follow directions stated on the product label. For health information, refer to the Safety Data Sheet (SDS) or call Chemtrec at 1-800-424-9300.

**Tyvek® Fluid Applied Products** may cause irritation. Repeated or prolonged skin contact may cause allergic reactions with susceptible persons. May cause irritation of respiratory tract. This product is a mixture. Health Hazard information is based on its components. Refer to the Safety Data Sheet (SDS) for further information.

## Safety and Handling (continued)

### KEEP OUT OF REACH OF CHILDREN.

Children can fall in to bucket and drown. Keep children away from bucket with even a small amount of liquid.

Use only as directed. Avoid inhalation of vapor aerosol.

### Caution

Obtain special instructions for **Tyvek® Fluid Applied Products** before use. Do not handle until all safety precautions have been read and understood. Avoid breathing dust/fumes/gas/mist/vapors/spray. Vapor and aerosols are harmful if using spray application. Use in a well-ventilated area. Use NIOSH approved respirator. NIOSH-approved particulate filtering full-face respirator with a P95 particulate filter or half-mask respirator with a P95 particulate filter and splash impact goggles when spraying. NIOSH-approved N95 disposable safety mask with splash impact goggles for manual application such as troweling or rolling, and for clean-up. If vapors are inhaled, immediately move from exposure to fresh air and contact a physician. Contaminated work clothing should not be allowed out of the workplace. Wear protective gloves/protective clothing/eye protection/face protection. IF ON SKIN: Wash with plenty of soap and water. IF IN EYES: Rinse cautiously with water for several minutes. Remove contact lenses, if present and easy to do. Continue rinsing. IF exposed or

concerned: Get medical advice/attention. Immediately call a POISON CENTER/doctor. If skin irritation or rash occurs: Get medical advice/ attention. Wash contaminated clothing before reuse. Store locked up. Dispose of contents/ container to an approved waste disposal plant. Avoid contact with eyes and skin.

When cured, **Great Stuff Pro™ Window & Door Polyurethane Foam Sealant** is combustible and will burn if exposed to open flame or sparks from high-energy sources. Do not expose to temperatures above 240°F (116°C). For more information, consult the Safety Data Sheet (SDS), call DuPont at 1-866-583-2583. When air sealing buildings, ensure that combustion appliances, such as furnaces, water heaters, wood burning stoves, gas stoves and gas dryers are properly vented to the outside. See website: <https://www.nrel.gov/docs/fy14osti/61326.pdf>.

In Canada visit: <https://nrc-publications.canada.ca/eng/view/ft/?id=96acba7c-afd4-4ea1-94b0-1f8f3500c582>.

**Great Stuff Pro™** polyurethane foam sealant and adhesive products contain isocyanate and a flammable blowing agent. Read all instructions and the Safety Data Sheet (SDS), carefully before use. Eliminate all sources of ignition before use. Cover all skin. Wear long sleeves, gloves, and safety glasses or goggles. Not for use in aviation, or food/beverage

contact, or as structural support in marine applications. Provide adequate ventilation or wear proper respiratory protection. Contents under pressure. Not to be used for filling closed cavities or voids such as behind walls and under tub surrounds; this improper use of the product could result in the accumulation of flammable vapors and/or uncured material. Failure to follow the warnings and instructions provided with the product, and/or all applicable rules and regulations, can result in injury or death.

Building and/or construction practices unrelated to building materials could greatly affect moisture and the potential for mold formation. No material supplied by DuPont can give assurance that mold will not develop in any specific system.

Read all instructions and the Safety Data Sheet (SDS) carefully before use.

For more information, visit [greatstuffpro.com](http://greatstuffpro.com) or [building.dupont.com](http://building.dupont.com)

### Hazard Statement

**Tyvek® Fluid Applied Products** may cause an allergic skin reaction. May cause serious eye damage. May cause genetic defects. May damage fertility or the unborn child. As it relates to California Prop 65, Tyvek® Fluid Applied Products can expose you to substances including Crystalline silica, which is /are known to the State of California to cause cancer. For more information, visit [p65Warnings.ca.gov](http://p65Warnings.ca.gov).

### For More Information

Visit the *Quick Links* section of our website (<https://www.dupont.com/building/resources.html>) where you'll find links to essential documents and resources to help you get the job done right:

- Installation Guidelines
- Safety Data Sheets (SDS)
- CAD Drawings
- DuPont Performance Building Solutions Document Library

For complete warranty information please call 1-833-338-7668 or visit us at [building.dupont.com](http://building.dupont.com).

*NOTICE: No freedom from any patent owned by DuPont or others is to be inferred. Because use conditions and applicable laws may differ from one location to another and may change with time, Customer is responsible for determining whether products and the information in this document are appropriate for Customer's use and for ensuring that Customer's workplace and disposal practices are in compliance with applicable laws and other government enactments. The product shown in this literature may not be available for sale and/or available in all geographies where DuPont is represented. The claims made may not have been approved for use in all countries or regions. DuPont assumes no obligation or liability for the information in this document. References to "DuPont" or the "Company" mean the DuPont legal entity selling the products to Customer unless otherwise expressly noted. NO EXPRESS WARRANTIES ARE GIVEN EXCEPT FOR ANY APPLICABLE WRITTEN WARRANTIES SPECIFICALLY PROVIDED BY DUPONT. ALL IMPLIED WARRANTIES INCLUDING THOSE OF MERCHANTABILITY AND FITNESS FOR A PARTICULAR PURPOSE ARE EXPRESSLY EXCLUDED. The buyer assumes all risks as to the use of the material. Buyer's exclusive remedy or any claim (including without limitations, negligence, strict liability, or tort) shall be limited to the refund of the purchase price of the material. Failure to strictly adhere to any recommended procedures shall release DuPont de Nemours, Inc., and its affiliates, of all liability with respect to the materials or the use thereof. The information herein is not intended for use by non-professional designers, applicators or other persons who do not purchase or utilize this product in the normal course of their business.*

© 2021 DuPont. DuPont™, the DuPont Oval Logo, and all trademarks and service marks denoted with ™, SM or ® are owned by affiliates of DuPont de Nemours, Inc. unless otherwise noted. Stinger® is a registered trademark of National Nail Corp. Grip-Deck®, Grip-Lok®, and Thermal-Grip FastCap™ are trademarks or registered trademarks of TRUFAST. Tower® is a registered trademark of Tower Sealants.

43-D101049-enUS-0921



For more information about  
DuPont Performance Building Solutions,  
please call 1-833-338-7668 or visit us at  
[building.dupont.com](http://building.dupont.com)